

# Dell PowerEdge R670

## Installation and Service Manual

## Notes, cautions, and warnings

 **NOTE:** A NOTE indicates important information that helps you make better use of your product.

 **CAUTION:** A CAUTION indicates either potential damage to hardware or loss of data and tells you how to avoid the problem.

 **WARNING:** A WARNING indicates a potential for property damage, personal injury, or death.

<b>Chapter 1: About this document</b> .....	<b>8</b>
<b>Chapter 2: PowerEdge R670 system configurations and features</b> .....	<b>9</b>
System configurations - front view for PowerEdge R670 system.....	9
Left Control Panel (LCP) - Secondary view.....	13
Right Control Panel (RCP) - Primary view.....	14
System configurations - rear view for PowerEdge R670 system.....	15
System configurations - inside view for PowerEdge R670 system.....	19
Locating the Express Service Code and Service Tag.....	22
System information label.....	23
Rail sizing and rack compatibility matrix.....	27
<b>Chapter 3: Technical specifications</b> .....	<b>28</b>
Chassis I/O Configuration.....	28
Chassis dimensions .....	29
System weight.....	30
Processor specifications.....	30
Cooling fan specifications.....	31
PSU specifications.....	32
Supported operating system.....	33
System battery specifications.....	33
Expansion card riser specifications.....	33
Memory specifications.....	34
Storage controller specifications.....	35
Drives.....	35
GPU Specifications.....	36
DPU Specifications.....	36
Ports and connectors specifications.....	36
NIC port specifications.....	36
Serial connector specifications.....	36
USB ports specifications.....	37
VGA ports specifications.....	37
Video specifications.....	37
Environmental specifications.....	37
Thermal restriction matrix.....	38
Particulate and gaseous contamination specifications.....	44
<b>Chapter 4: Initial system setup and configuration</b> .....	<b>45</b>
Setting up the system.....	45
iDRAC configuration.....	45
Options to set up iDRAC IP address.....	45
Options to log in to iDRAC.....	46
Resources to install operating system.....	46
Options to download drivers and firmware .....	47

Options to download and install OS drivers .....	47
Downloading drivers and firmware.....	47
<b>Chapter 5: Pre-operating system management applications.....</b>	<b>49</b>
System Setup.....	49
System BIOS.....	50
iDRAC Settings.....	50
Device Settings.....	50
Boot Manager.....	50
PXE boot.....	50
<b>Chapter 6: Minimum to POST and system management configuration validation.....</b>	<b>51</b>
Minimum configuration to POST .....	51
<b>Chapter 7: Configuration validation.....</b>	<b>52</b>
<b>Chapter 8: Disassembly and reassembly.....</b>	<b>53</b>
Safety instructions.....	53
Before working inside your system .....	54
After working inside your system.....	54
Recommended tools.....	54
Optional front bezel.....	55
Removing the front bezel.....	55
Installing the front bezel.....	56
System cover.....	56
Removing the system cover.....	56
Installing the system cover.....	57
Cooling fans.....	58
Removing a cooling fan.....	58
Installing a cooling fan.....	59
Air shroud.....	61
Removing the air shroud.....	61
Installing the air shroud.....	61
Drive backplane cover.....	62
Removing the drive backplane cover.....	62
Installing the drive backplane cover.....	63
PERC modules.....	64
Removing the rear mounting front PERC module.....	64
Installing the rear mounting front PERC module.....	66
Removing the front H975i PERC module.....	68
Installing the front H975i PERC module.....	70
Drives.....	73
Removing a 2.5-inch drive blank.....	73
Installing a 2.5-inch drive blank.....	73
Removing a 2.5-inch drive carrier.....	73
Removing a 2.5-inch drive from the drive carrier.....	74
Installing a 2.5-inch drive into the drive carrier.....	75
Installing a 2.5-inch drive carrier.....	75
Removing an EDSFF E3.S drive blank.....	76

Installing an EDSFF E3.S drive blank.....	77
Removing an EDSFF E3.S drive carrier.....	77
Installing an EDSFF E3.S drive carrier.....	78
Removing an EDSFF E3.S drive from the drive carrier.....	79
Installing an EDSFF E3.S drive into the drive carrier.....	80
Drive backplane.....	80
Drive backplane.....	80
Removing the 2.5-inch drive backplane module.....	81
Installing the 2.5-inch drive backplane module.....	81
Removing the EDSFF E3.S backplane module.....	82
Installing the EDSFF E3.S backplane module.....	83
Removing the PERC backplane .....	84
Installing the PERC backplane.....	85
Side wall brackets.....	87
Removing the side wall bracket.....	87
Installing the side wall bracket.....	88
Middle bracket.....	89
Removing the cables from the middle bracket .....	89
Installing the cables into the middle bracket .....	90
Cable routing.....	91
System memory.....	114
System memory guidelines.....	114
General memory module installation guidelines.....	116
Removing a memory module.....	116
Installing a memory module.....	117
Processor and heat sink.....	118
Removing the processor and heat sink module.....	118
Removing the processor.....	120
Installing the processor.....	122
Installing the processor and heat sink module.....	125
Removing the Direct Liquid Cooling module.....	127
Installing the Direct Liquid Cooling module.....	128
Expansion cards and expansion card risers.....	129
Expansion card installation guidelines.....	130
Removing the front expansion card risers.....	139
Installing the front expansion card risers.....	140
Removing the rear expansion card risers.....	141
Installing the rear expansion card risers.....	143
Removing an expansion card from the expansion card riser.....	145
Installing an expansion card into the expansion card riser.....	151
Removing the rear expansion card riser blank.....	157
Installing the rear expansion card riser blank.....	158
M.2 SSD module.....	159
Removing the M.2 NVMe SSD module from the BOSS-N1 DC-MHS card carrier.....	159
Installing the M.2 NVMe SSD module in the BOSS-N1 DC-MHS card carrier.....	161
Removing the M.2 NVMe SSD module from the M.2 Interposer board.....	165
Installing the M.2 NVMe SSD module in the M.2 Interposer board.....	166
Optional BOSS-N1 DC-MHS module.....	171
Removing the front BOSS-N1 DC-MHS module.....	171
Installing the front BOSS-N1 DC-MHS module.....	174

Removing the rear BOSS-N1 DC-MHS module.....	176
Installing the rear BOSS-N1 DC-MHS module.....	178
BOSS-N1 DC-MHS - Replacement instructions .....	179
Optional M.2 Interposer board.....	183
Removing the M.2 Interposer board.....	183
Installing the M.2 Interposer board.....	185
Optional OCP NIC card.....	190
Removing the front OCP NIC card.....	190
Installing the front OCP NIC card.....	191
Removing the front OCP NIC cage.....	193
Installing the front OCP NIC cage.....	194
Removing the rear OCP NIC card.....	196
Installing the rear OCP NIC card.....	197
Datacenter-Secure Control Module (DC-SCM).....	199
Removing the DC-SCM board.....	199
Installing the DC-SCM board.....	200
Restoring the system using Easy Restore.....	201
Manually update the Service Tag.....	202
Attic board.....	202
Removing the Attic board.....	202
Installing the Attic board.....	203
Optional internal USB port.....	204
Removing the internal USB device.....	204
Installing the Internal USB device.....	205
System battery.....	206
Replacing the system battery.....	206
Intrusion switch.....	208
Removing the intrusion switch module.....	208
Installing the intrusion switch module.....	209
Power supply unit.....	210
Removing a power supply unit.....	210
Installing a power supply unit.....	211
Removing a power supply unit blank.....	212
Installing a power supply unit blank.....	213
DB9+RJ45 module.....	214
Removing the DB9+RJ45 module.....	214
Installing the DB9+RJ45 module.....	215
Trusted Platform Module.....	216
Initializing TPM 2.0 for users.....	216
HPM board.....	217
Removing the HPM board.....	217
Installing the HPM board.....	218
Control panel.....	219
Removing the right control panel.....	219
Installing the right control panel.....	220
Removing the KVM left control panel.....	221
Installing the KVM left control panel.....	222
<b>Chapter 9: Upgrade Kits.....</b>	<b>224</b>
Processor upgrade guidelines.....	224

<b>Chapter 10: System diagnostics and indicator codes.....</b>	<b>226</b>
Power button LED.....	226
System health and system ID indicator codes.....	227
iDRAC Direct LED indicator codes.....	227
NIC indicator codes.....	228
Power supply unit indicator codes.....	228
EDSFF E3.S drive led codes.....	229
Using system diagnostics.....	230
Dell Embedded System Diagnostics.....	230
<b>Chapter 11: HPM board connectors and DIP Switches.....</b>	<b>232</b>
System board connectors and DIP switches.....	232
DIP switch settings.....	234
Disable a password.....	234
<b>Chapter 12: Getting Help.....</b>	<b>235</b>
Recycling or End-of-Life service information.....	235
Contact Dell Technologies.....	235
Accessing system information by using MyDell.....	235
QR code for PowerEdge R670 system resources.....	236
Receiving automated support with Secure Connect Gateway (SCG).....	236
<b>Chapter 13: Documentation resources.....</b>	<b>237</b>

# About this document

This document provides an overview about the system, information about installing and replacing components, diagnostic tools, and guidelines to be followed while installing certain components.

# PowerEdge R670 system configurations and features

The PowerEdge R670 system is a 1U server that supports:

- Two Intel Xeon 6 Processors with up to 144 E-Cores or 86 P-cores
- Optional Direct Liquid Cooling (DLC) for required CPU SKU and/or configurations
- 32 DIMM slots
- Two AC or DC power supply units
- No backplane configuration
- Up to 8 x EDSFF E3.S NVMe drives
- Up to 8 x EDSFF E3.S NVMe drives FIO configuration
- Up to 16 x EDSFF E3.S NVMe drives
- Up to 20 x EDSFF E3.S NVMe drives
- Up to 2 x EDSFF E3.S NVMe drives in the rear
- Up to 8 x 2.5-inch SATA/ NVMe drives
- Up to 8 x 2.5-inch Universal drives
- Up to 10 x 2.5-inch SATA drives

**NOTE:** For more information about how to hot swap NVMe PCIe SSD device, see the *Dell Express Flash NVMe PCIe SSD User's Guide* at [Dell Support](#) page > **Browse all products** > **Infrastructure** > **Data Center Infrastructure** > **Storage Adapters & Controllers** > **Dell PowerEdge Express Flash NVMe PCIe SSD** > **Select This Product** > **Documentation** > **Manuals and Documents**.

**NOTE:** All instances of SATA drives are referred to as drives in this document, unless specified otherwise.

**CAUTION:** Do not install GPUs, network cards, or other PCIe devices on your system that are not validated and tested by Dell. Damage caused by unauthorized and invalidated hardware installation will null and void the system warranty.

## Topics:

- [System configurations - front view for PowerEdge R670 system](#)
- [System configurations - rear view for PowerEdge R670 system](#)
- [System configurations - inside view for PowerEdge R670 system](#)
- [Locating the Express Service Code and Service Tag](#)
- [System information label](#)
- [Rail sizing and rack compatibility matrix](#)

## System configurations - front view for PowerEdge R670 system

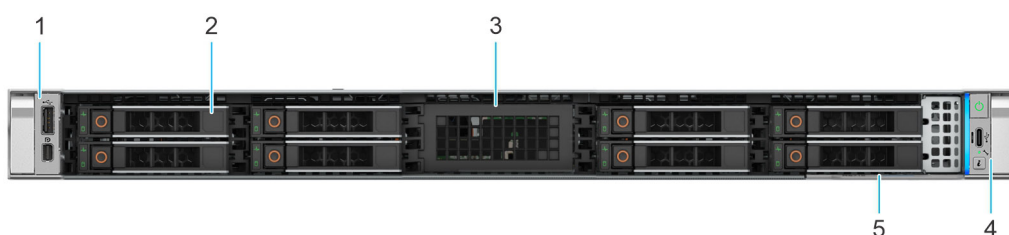

Figure 1. Front view of 8 x 2.5-inch drive system

**Table 1. Front view of 8 x 2.5-inch drive system**

Item	Ports, panels, and slots	Icon	Description
1	Left Control Panel (LCP) - Secondary	N/A	Contains the USB port and Mini-Displayport. <b>NOTE:</b> KVM module is optional, and LCP - Secondary blank is default in the left control panel.
2	Drive	N/A	Enables you to install drives that are supported on your system.
3	Blank	N/A	N/A
4	Right Control Panel (RCP) - Primary	N/A	Contains the system health, system ID, power button, Type-C USB port, and the host status LED.
5	Express Service Tag	N/A	The Express Service Tag is a slide-out label panel that contains system information such as Service Tag, NIC, MAC address, and so on.



**Figure 2. Front view of 10 x 2.5-inch drive system**

**Table 2. Front view of 10 x 2.5-inch drive system**

Item	Ports, panels, and slots	Icon	Description
1	Left Control Panel (LCP) - Secondary	N/A	Contains the USB port and Mini-Displayport. <b>NOTE:</b> KVM module is optional, and LCP - Secondary blank is default in the left control panel.
2	Drive	N/A	Enables you to install drives that are supported on your system.
3	Right Control Panel (RCP) - Primary	N/A	Contains the system health, system ID, power button, Type-C USB port, and the host status LED.
4	Express Service Tag	N/A	The Express Service Tag is a slide-out label panel that contains system information such as Service Tag, NIC, MAC address, and so on.

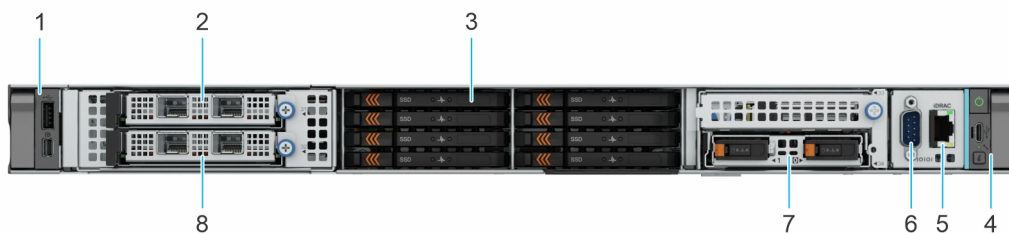

**Figure 3. Front view of 8 x EDSFF E3.S drive system with front I/O configuration**

**Table 3. Front view of 8 x EDSFF E3.S drive system with front I/O configuration**

Item	Ports, panels, and slots	Icon	Description
1	Left Control Panel (LCP) - Secondary	N/A	Contains the USB port and Mini-Displayport. <b>NOTE:</b> KVM module is optional, and LCP - Secondary blank is default in the left control panel.

**Table 3. Front view of 8 x EDSFF E3.S drive system with front I/O configuration (continued)**

Item	Ports, panels, and slots	Icon	Description
2	OCP NIC	N/A	The OCP NIC card supports OCP 3.0. The NIC ports are integrated on the OCP card which is connected to the system board.
3	Drive	N/A	Enables you to install drives that are supported on your system.
4	Right Control Panel (RCP) - Primary	N/A	Contains the system health, system ID, power button, Type-C USB port, and the host status LED.
5	Dedicated iDRAC Ethernet port	N/A	Enables you to remotely access the iDRAC port.
6	Serial COM port	IOIOI	Enables you to connect a serial device to the system.
7	BOSS-N1 DC-MHS	N/A	Enables you to install the BOSS-N1 DC-MHS controller.
8	Primary OCP NIC	N/A	The OCP NIC card supports OCP 3.0. The NIC ports are integrated on the OCP card which is connected to the system board. <b>NOTE:</b> The primary OCP NIC card shares a NIC port with the iDRAC.

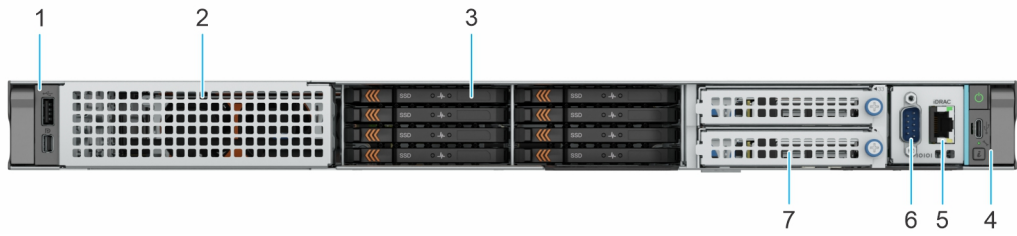

**Figure 4. Front view of 8 x EDSFF E3.S drive system with rear I/O configuration**

**Table 4. Front view of 8 x EDSFF E3.S drive system with rear I/O configuration**

Item	Ports, panels, and slots	Icon	Description
1	Left Control Panel (LCP) - Secondary	N/A	Contains the USB port and Mini-Displayport. <b>NOTE:</b> KVM module is optional in left control panel.
2	OCP blank	N/A	The OCP blank is installed.
3	Drive	N/A	Enables you to install drives that are supported on your system.
4	Right Control Panel (RCP) - Primary	N/A	Contains the system health, system ID, power button, Type-C USB port, and the host status LED.
5	Dedicated iDRAC Ethernet port	N/A	Enables you to remotely access the iDRAC port.
6	Serial COM port	IOIOI	Enables you to connect a serial device to the system.
7	OCP/BOSS filler bracket	N/A	The OCP/BOSS filler bracket is installed.

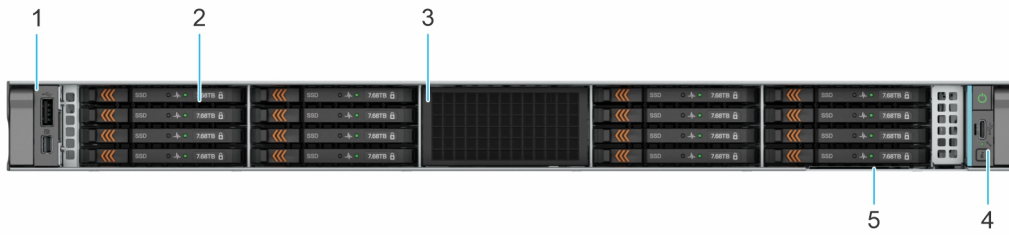

Figure 5. Front view of 16 x EDSFF E3.S drive system

Table 5. Front view of 16 x EDSFF E3.S drive system

Item	Ports, panels, and slots	Icon	Description
1	Left Control Panel (LCP) - Secondary	N/A	Contains the USB port and Mini-Displayport. <b>NOTE:</b> KVM module is optional, and LCP - Secondary blank is default in the left control panel.
2	Drive	N/A	Enables you to install drives that are supported on your system.
3	Blank	N/A	N/A
4	Right Control Panel (RCP) - Primary	N/A	Contains the system health, system ID, power button, Type-C USB port, and the host status LED.
5	Express Service Tag	N/A	The Express Service Tag is a slide-out label panel that contains system information such as Service Tag, NIC, MAC address, and so on.



Figure 6. Front view of 20 x EDSFF E3.S drive system

Table 6. Front view of 20 x EDSFF E3.S drive system

Item	Ports, panels, and slots	Icon	Description
1	Left Control Panel (LCP) - Secondary	N/A	Contains the USB port and Mini-Displayport. <b>NOTE:</b> KVM module is optional, and LCP - Secondary blank is default in the left control panel.
2	Drive	N/A	Enables you to install drives that are supported on your system.
3	Right Control Panel (RCP) - Primary	N/A	Contains the system health, system ID, power button, Type-C USB port, and the host status LED.
4	Express Service Tag	N/A	The Express Service Tag is a slide-out label panel that contains system information such as Service Tag, NIC, MAC address, and so on.

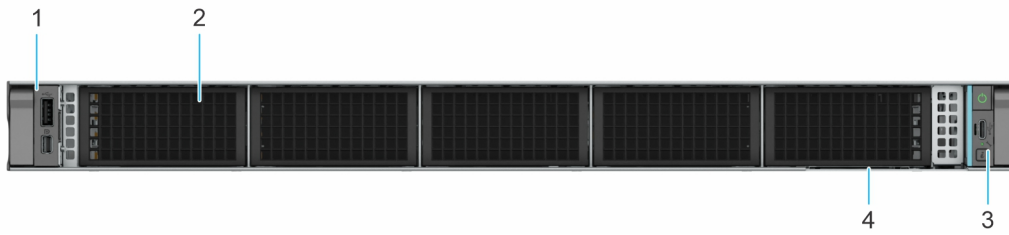

Figure 7. Front view of No BP configuration

Table 7. Front view of No BP configuration

Item	Ports, panels, and slots	Icon	Description
1	Left Control Panel (LCP) - Secondary	N/A	Contains the USB port and Mini-Displayport. <b>NOTE:</b> KVM module is optional, and LCP - Secondary blank is default in the left control panel.
2	Blank	N/A	N/A
3	Right Control Panel (RCP) - Primary	N/A	Contains the system health, system ID, power button, Type-C USB port, and the host status LED.
4	Express Service Tag	N/A	The Express Service Tag is a slide-out label panel that contains system information such as Service Tag, NIC, MAC address, and so on.

## Left Control Panel (LCP) - Secondary view



Figure 8. Left Control Panel (LCP) - Secondary blank (default)

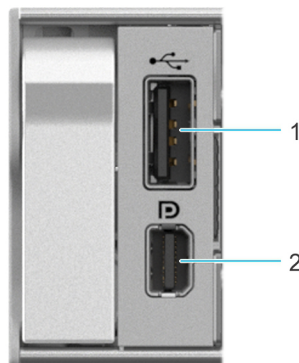

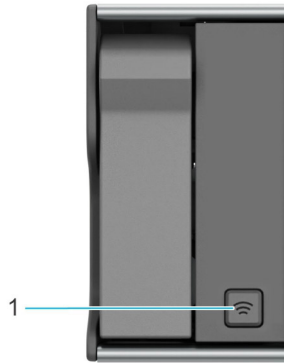

Figure 9. Left Control Panel (LCP) - Secondary with optional KVM

**Table 8. Left Control Panel (LCP) - Secondary with optional KVM**

Item	Ports	Icon	Description
1	USB 2.0-compliant port		The USB port is 4-pin, 2.0-compliant. This port enables you to connect USB devices to the system.
2	Mini-DisplayPort		Enables you to connect a display device to the system.





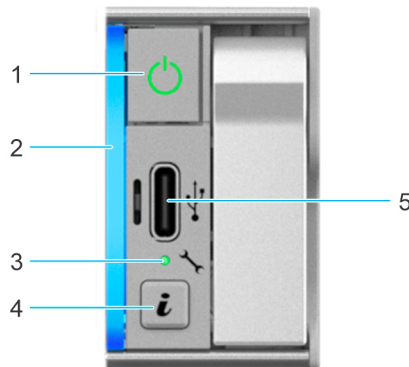

**Figure 10. Left Control Panel (LCP) - Secondary with optional Quick Sync 2.0**

## Right Control Panel (RCP) - Primary view



**Figure 11. Right Control Panel (RCP) - Primary**

**Table 9. Right Control Panel (RCP) - Primary**

Item	Indicator or button	Icon	Description
1	Power button		Indicates if the system is powered on or off. Press the power button to manually power on or off the system.
2	System health and System ID indicator	N/A	Indicates the status of the system. For more information, see the <a href="#">System health and system ID indicator codes</a> section.
3	Host mode LED		LED to identify the Host USB signal. <b>NOTE:</b> When the Type C USB port is owned by the host, the LED is off.
4	System ID button		System ID allows user to physically locate the system. For more information, see the <a href="#">System health and system ID indicator codes</a> section.
5	Type C USB 2.0		The USB port is 4-pin, 2.0-compliant. This port enables you to connect USB devices to the system.

**NOTE:** For more information about the ports, see the [Technical Specifications](#) section.

## System configurations - rear view for PowerEdge R670 system

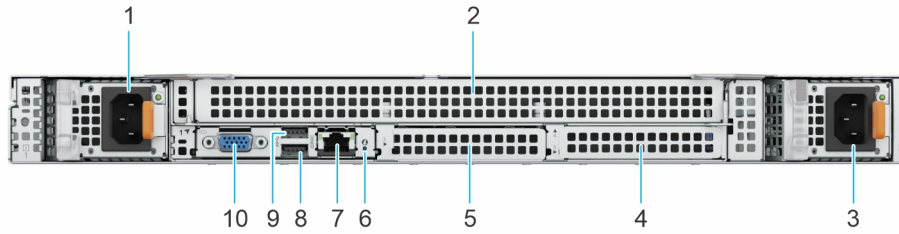

Figure 12. Rear view of the system with front I/O configuration

Table 10. Rear view of the system

Item	Ports, panels, or slots	Icon	Description
1	Power supply unit (PSU1)		PSU1 is the primary PSU of the system.
2	PCIe expansion card riser blank	N/A	In front I/O configuration PCIe expansion card riser blank is installed in PCIe expansion card riser bay.
3	Power supply unit (PSU2)		PSU2 is the secondary PSU of the system.
4	OCP NIC card filler bracket	N/A	In the front I/O configuration, an OCP filler bracket is installed in the OCP NIC card bay.
5	BOSS filler bracket	N/A	In the front I/O configuration, the BOSS file bracket is installed in BOSS-N1 DC-MHS bay.
6	SID LED	N/A	Rear system identification LED
7	iDRAC dedicated port		Enables you to remotely access iDRAC. When the front iDRAC port is connected to the network, the rear iDRAC port is automatically disabled.
8	USB 3.0 port		The USB port is 9-pin and 3.0-compliant. This port enables you to connect USB devices to the system.
9	USB 3.0 port		The USB port is 9-pin and 3.0-compliant. This port enables you to connect USB devices to the system.
10	VGA port		Enables you to connect a display device to the system.

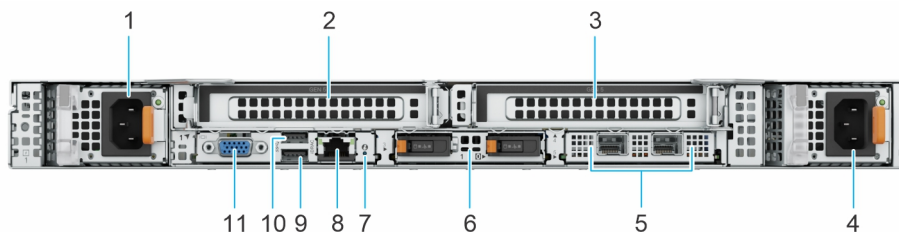
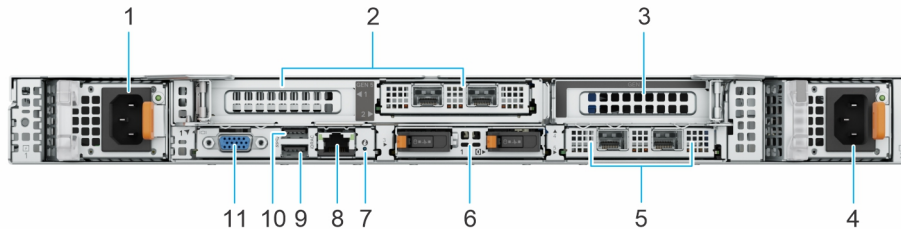

Figure 13. Rear view of the system with rear I/O configuration with riser R2b and R4b

**Table 11. Rear view of the system**

Item	Ports, panels, or slots	Icon	Description
1	Power supply unit (PSU1)		PSU1 is the primary PSU of the system.
2	PCIe expansion card riser 2b	N/A	The expansion card riser enables you to connect PCI Express expansion cards.
3	PCIe expansion card riser 4b	N/A	The expansion card riser enables you to connect PCI Express expansion cards.
4	Power supply unit (PSU2)		PSU2 is the secondary PSU of the system.
5	OCP NIC port	N/A	The OCP NIC card supports OCP 3.0. The NIC ports are integrated on the OCP card which is connected to the system board and also supports the iDRAC shared NIC feature.
6	BOSS-N1 DC-MHS module	N/A	BOSS module for internal system boot.
7	SID LED	N/A	Rear system identification LED
8	iDRAC dedicated port		Enables you to remotely access iDRAC. When the front iDRAC port is connected to the network, the rear iDRAC port is automatically disabled.
9	USB 3.0 port		The USB port is 9-pin and 3.0-compliant. This port enables you to connect USB devices to the system.
10	USB 3.0 port		The USB port is 9-pin and 3.0-compliant. This port enables you to connect USB devices to the system.
11	VGA port		Enables you to connect a display device to the system.







**Figure 14. Rear view of the system with rear I/O configuration with riser R2f and R4a**

**Table 12. Rear view of the system**

Item	Ports, panels, or slots	Icon	Description
1	Power supply unit (PSU1)		PSU1 is the primary PSU of the system.
2	PCIe expansion card riser 2f with OCP NIC card	N/A	The expansion card riser enables you to connect PCI Express expansion cards.
3	PCIe expansion card riser 4a	N/A	The expansion card riser enables you to connect PCI Express expansion cards.
4	Power supply unit (PSU2)		PSU2 is the secondary PSU of the system.
5	OCP NIC port	N/A	The OCP NIC card supports OCP 3.0. The NIC ports are integrated on the OCP card which is connected to the system board and also supports the iDRAC shared NIC feature.
6	BOSS-N1 DC-MHS module	N/A	BOSS module for internal system boot.





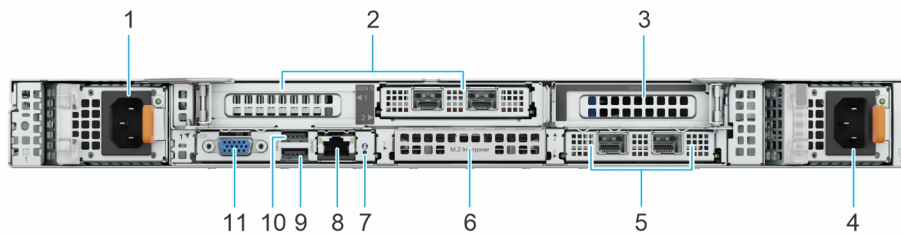

**Table 12. Rear view of the system (continued)**

Item	Ports, panels, or slots	Icon	Description
7	SID LED	N/A	Rear system identification LED
8	iDRAC dedicated port		Enables you to remotely access iDRAC. When the front iDRAC port is connected to the network, the rear iDRAC port is automatically disabled.
9	USB 3.0 port		The USB port is 9-pin and 3.0-compliant. This port enables you to connect USB devices to the system.
10	USB 3.0 port		The USB port is 9-pin and 3.0-compliant. This port enables you to connect USB devices to the system.
11	VGA port		Enables you to connect a display device to the system.



**Figure 15. Rear view of the system with rear I/O configuration with riser R2f and R4a and M.2 Interposer board**

**Table 13. Rear view of the system**

Item	Ports, panels, or slots	Icon	Description
1	Power supply unit (PSU1)	 1	PSU1 is the primary PSU of the system.
2	PCIe expansion card riser 2f with OCP NIC card	N/A	The expansion card riser enables you to connect PCI Express expansion cards.
3	PCIe expansion card riser 4a	N/A	The expansion card riser enables you to connect PCI Express expansion cards.
4	Power supply unit (PSU2)	 2	PSU2 is the secondary PSU of the system.
5	OCP NIC port	N/A	The OCP NIC card supports OCP 3.0. The NIC ports are integrated on the OCP card which is connected to the system board and also supports the iDRAC shared NIC feature.
6	M.2 Interposer board	N/A	M.2 Interposer board for internal system boot.
7	SID LED	N/A	Rear system identification LED
8	iDRAC dedicated port		Enables you to remotely access iDRAC. When the front iDRAC port is connected to the network, the rear iDRAC port is automatically disabled.
9	USB 3.0 port		The USB port is 9-pin and 3.0-compliant. This port enables you to connect USB devices to the system.
10	USB 3.0 port		The USB port is 9-pin and 3.0-compliant. This port enables you to connect USB devices to the system.
11	VGA port		Enables you to connect a display device to the system.

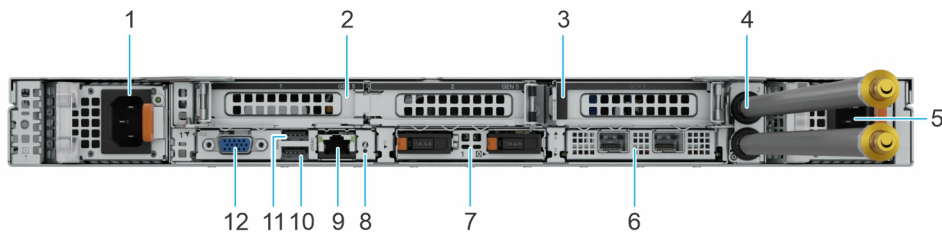





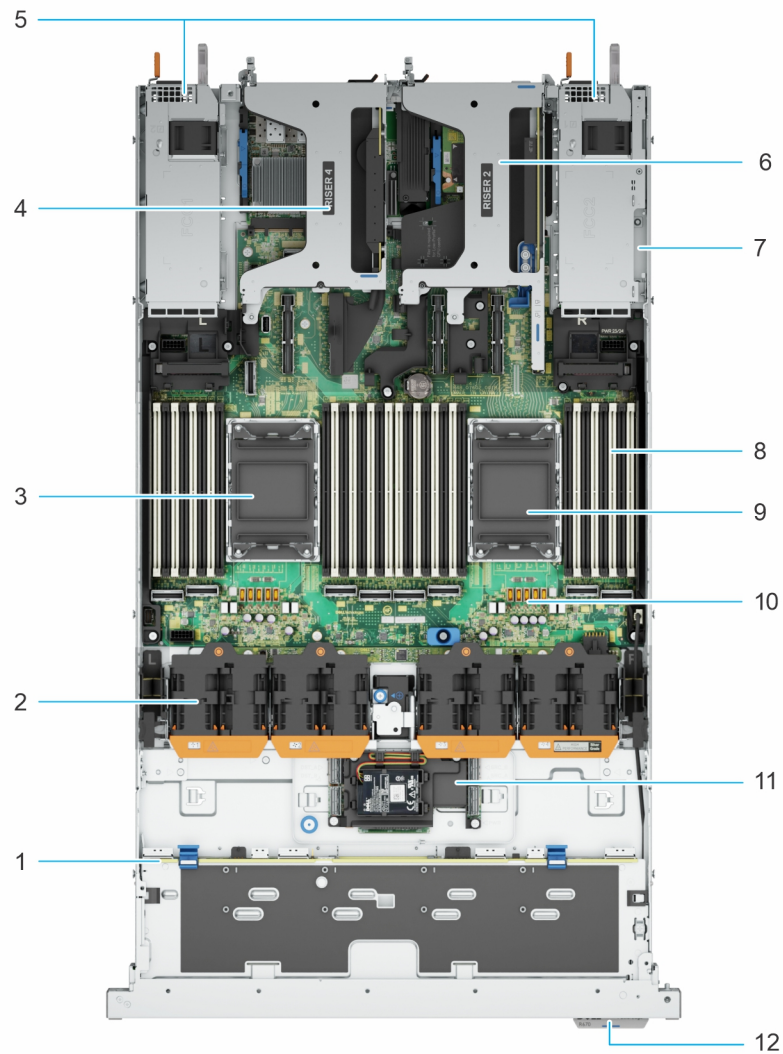

Figure 16. Rear view of the liquid cooling configuration

Table 14. Rear view of the liquid cooling configuration

Item	Ports, panels, or slots	Icon	Description
1	Power supply unit (PSU1)		PSU1 is the primary PSU of the system.
2	PCIe expansion card riser 2b	N/A	The expansion card riser enables you to connect PCI Express expansion cards.
3	PCIe expansion card riser 4b	N/A	The expansion card riser enables you to connect PCI Express expansion cards.
4	Liquid cooling module tubes	N/A	Cold coolant flows into the system from one tube and hot coolant leaves the system from another tube.
5	Power supply unit (PSU2)		PSU2 is the secondary PSU of the system.
6	OCP NIC card filler bracket	N/A	In the front I/O configuration, an OCP filler bracket is installed in the OCP NIC card bay.
7	BOSS-N1 DC-MHS module	N/A	BOSS module for internal system boot.
8	SID LED	N/A	Rear system identification LED
9	iDRAC dedicated port		Enables you to remotely access iDRAC. When the front iDRAC port is connected to the network, the rear iDRAC port is automatically disabled.
10	USB 3.0 port		The USB port is 9-pin and 3.0-compliant. This port enables you to connect USB devices to the system.
11	USB 3.0 port		The USB port is 9-pin and 3.0-compliant. This port enables you to connect USB devices to the system.
12	VGA port		Enables you to connect a display device to the system.

# System configurations - inside view for PowerEdge R670 system



**Figure 17. PowerEdge R670 system - inside the system with risers**

- |                               |                               |
|-------------------------------|-------------------------------|
| 1. Backplane                  | 2. Cooling fans               |
| 3. Dust cover for Processor 0 | 4. Riser 4                    |
| 5. PSUs                       | 6. Riser 2                    |
| 7. Intrusion switch           | 8. Memory module slots (DIMM) |
| 9. Dust cover for Processor 1 | 10. System board              |
| 11. Front PERC                | 12. Express Service Tag       |

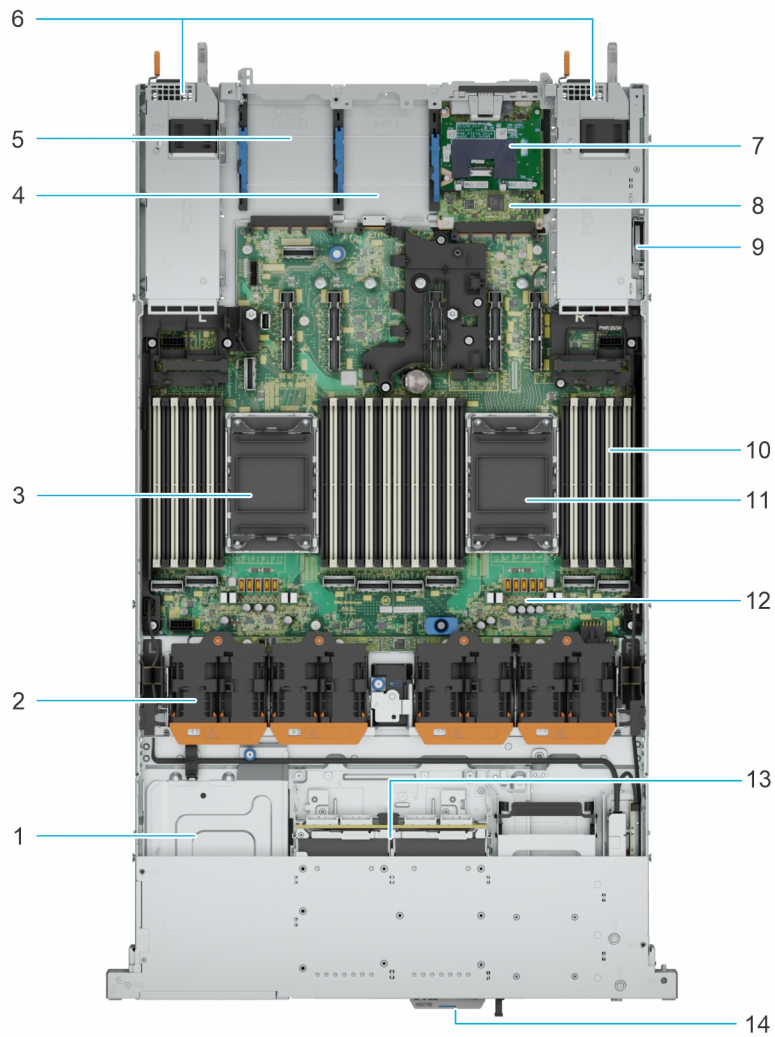

**Figure 18. PowerEdge R670 system - inside the system without risers**

- |                                |                                |
|--------------------------------|--------------------------------|
| 1. Front riser                 | 2. Cooling fans                |
| 3. Dust cover for Processor 0  | 4. BOSS-N1 DC-MHS module slot  |
| 5. OCP NIC card slot           | 6. PSUs                        |
| 7. Attic board                 | 8. DC-SCM card                 |
| 9. Intrusion switch            | 10. Memory module slots (DIMM) |
| 11. Dust cover for Processor 1 | 12. System board               |
| 13. Backplane                  | 14. Express Service Tag        |

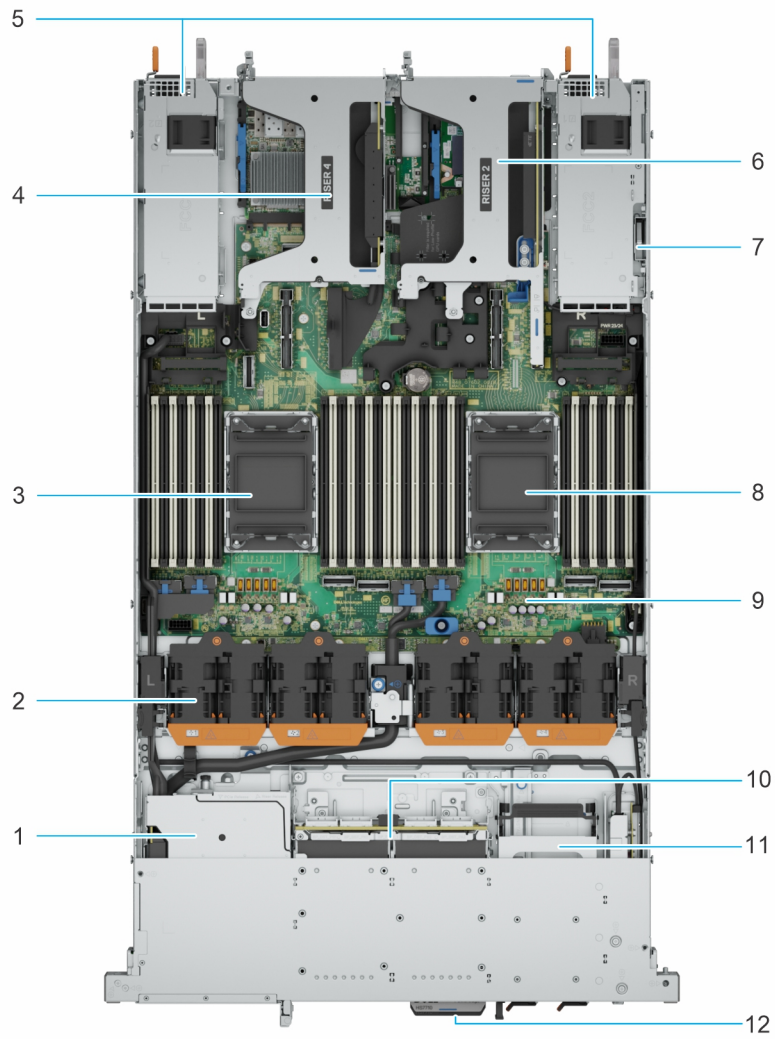

**Figure 19. PowerEdge R670 system - inside the system with risers**

- |                               |                               |
|-------------------------------|-------------------------------|
| 1. Front riser                | 2. Cooling fans               |
| 3. Dust cover for Processor 0 | 4. Riser 4                    |
| 5. PSUs                       | 6. Riser 2                    |
| 7. Intrusion switch           | 8. Dust cover for Processor 1 |
| 9. System board               | 10. Backplane                 |
| 11. BOSS-N1 DC-MHS module     | 12. Express Service Tag       |

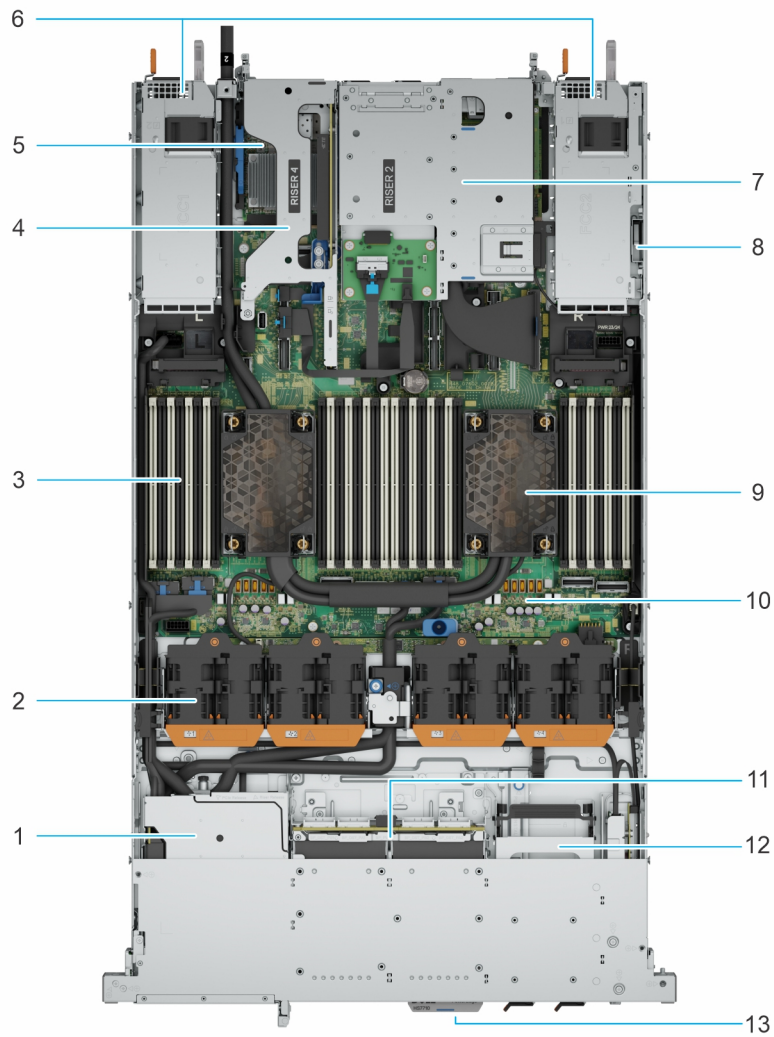

**Figure 20. PowerEdge R670 system - inside the system with processor liquid cooling module**

- |                                    |                           |
|------------------------------------|---------------------------|
| 1. Backplane                       | 2. Cooling fans           |
| 3. Memory module slots (DIMM)      | 4. Riser 4                |
| 5. OCP NIC card slot               | 6. PSUs                   |
| 7. Riser 2                         | 8. Intrusion switch       |
| 9. Processor liquid cooling module | 10. System board          |
| 11. Backplane                      | 12. BOSS-N1 DC-MHS module |
| 13. Express Service Tag            |                           |

## Locating the Express Service Code and Service Tag

The unique Express Service Code and Service Tag are used to identify the system.

The information tag is located on the front of the system that includes system information such as the Service Tag, Express Service Code, Manufacture date, NIC, MAC address, My Dell QR code, and so on.

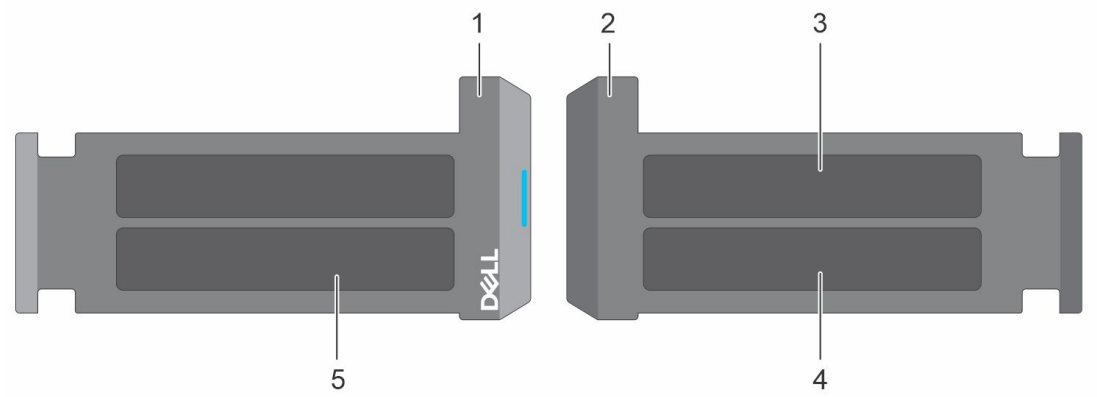

**Figure 21. Locating the Express Service Code and Service Tag**

1. Express Service Tag (front view)
2. Express Service Tag (rear view)
3. OMM (Not applicable)
4. Password and MAC address
5. Service Tag, Express Service Code, My Dell QR label

## System information label

The system information label is located on the back of the system cover.

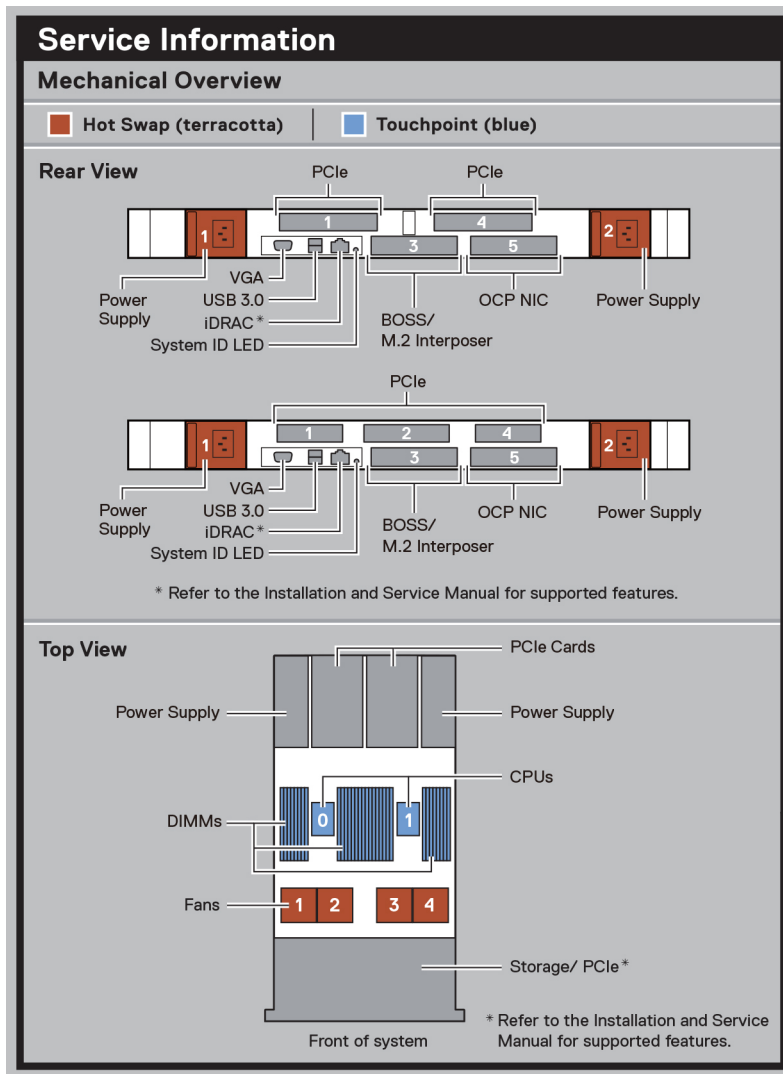

Figure 22. Service information

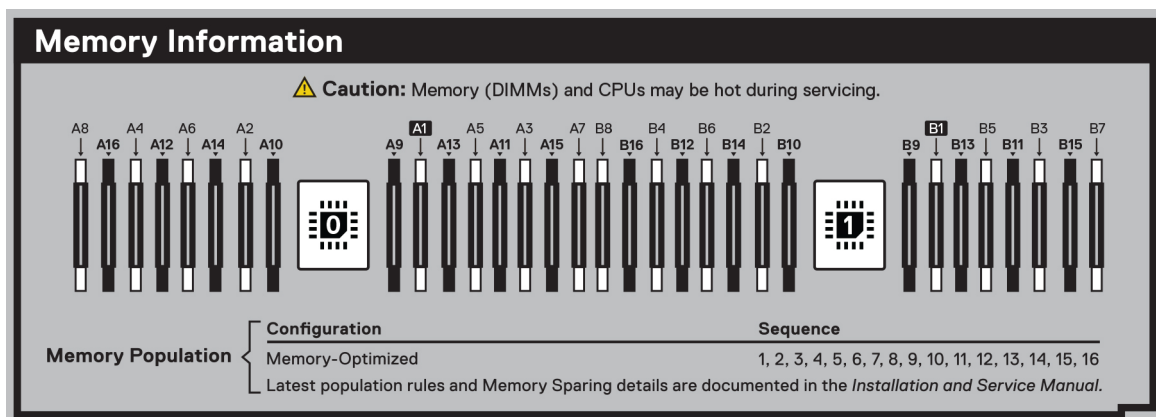

Figure 23. Memory information

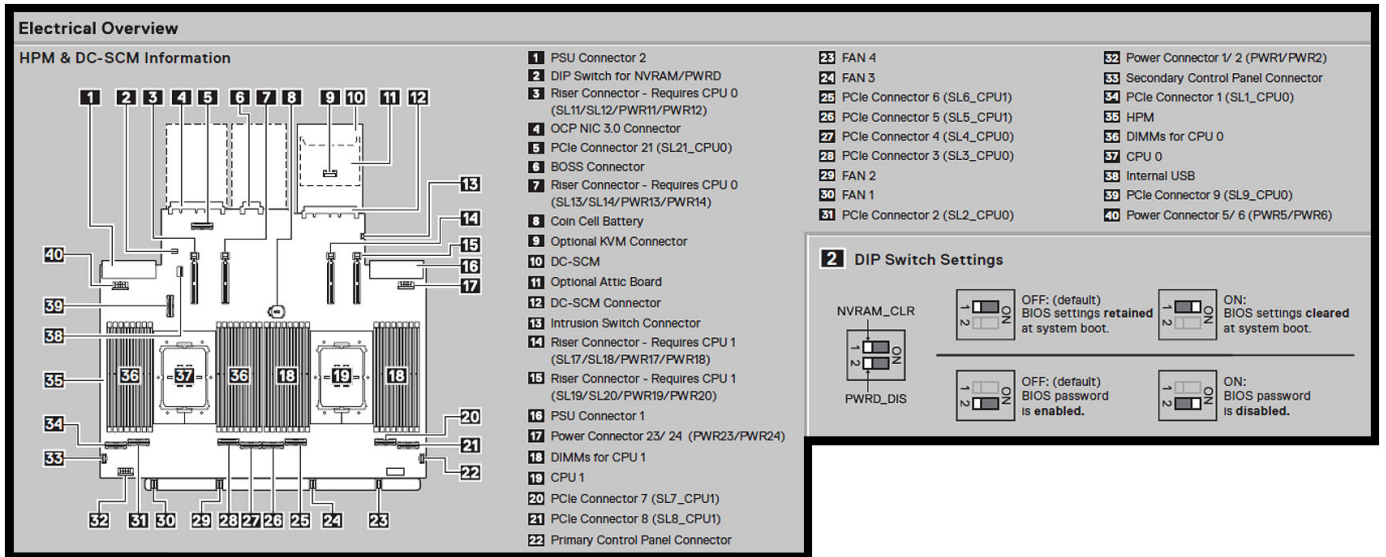

Figure 24. Electrical overview

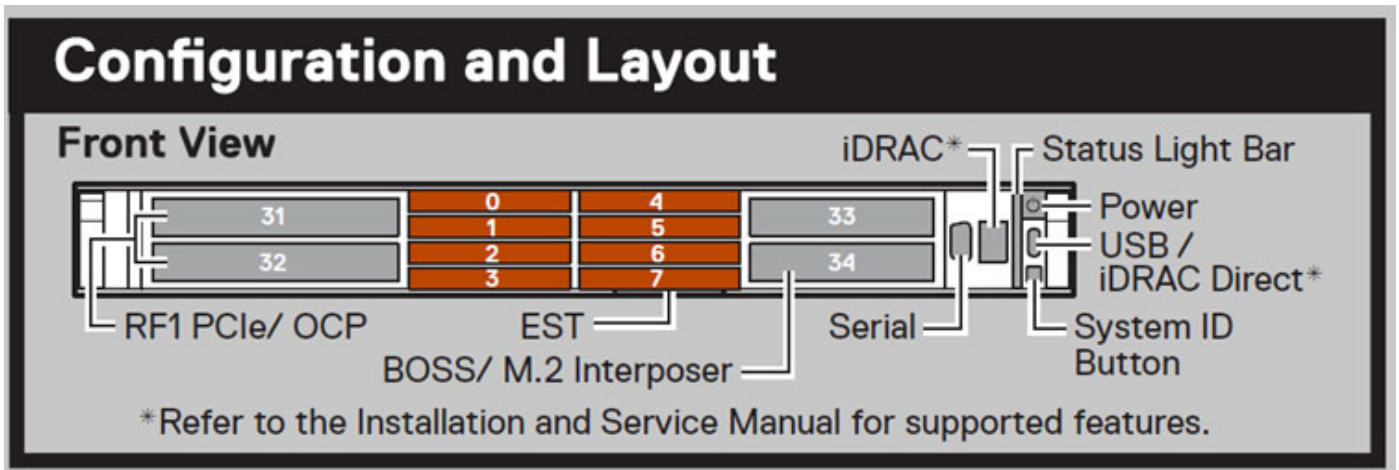

Figure 25. Configuration and Layout

# Configuration and Layout

## Front View

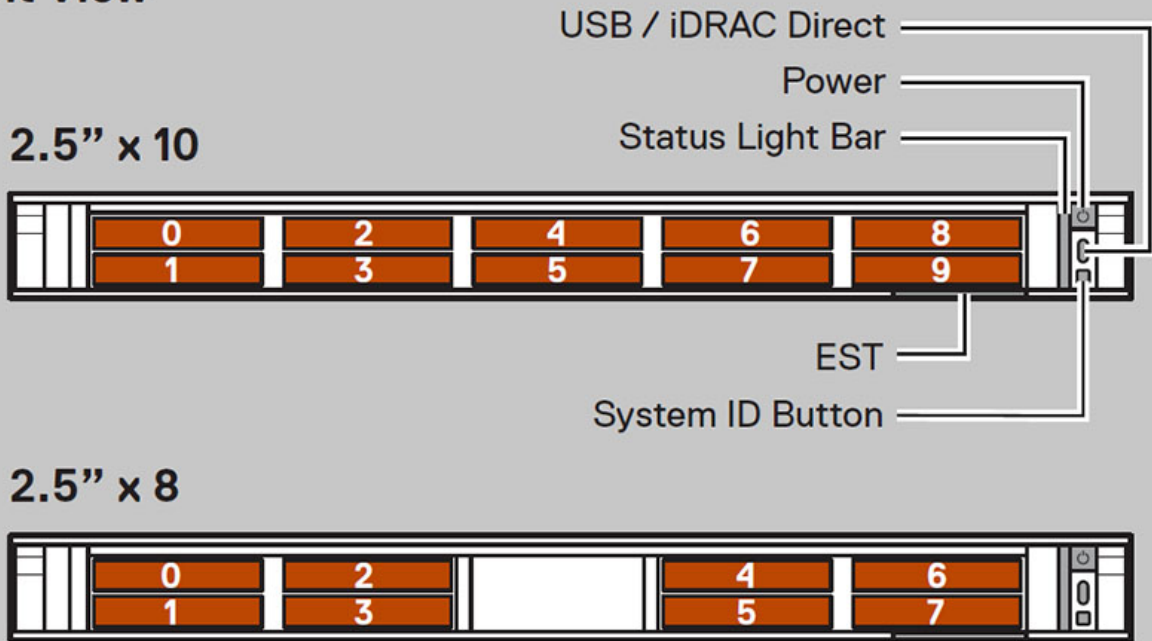

Figure 26. Configuration and Layout

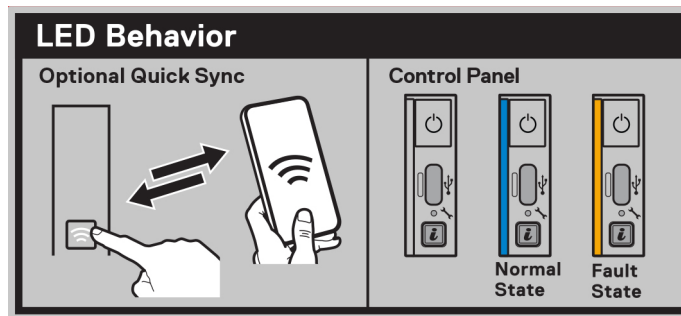

Figure 27. LED behavior

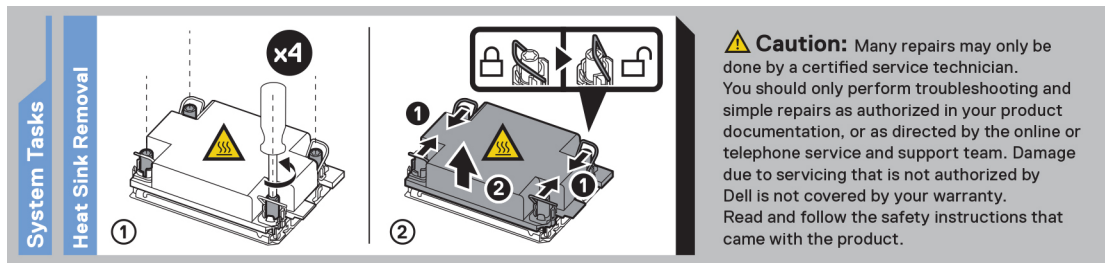

Figure 28. System tasks

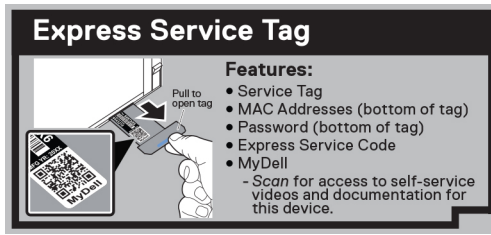

Figure 29. Express Service Tag

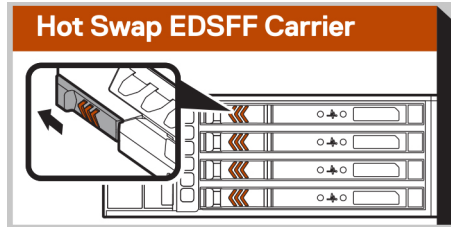

Figure 30. EDSFF carrier

## Rail sizing and rack compatibility matrix

For specific information about the rail solutions compatible with your system, see the *Dell Enterprise Systems Rail Sizing and Rack Compatibility Matrix* available at [rail-rack-matrix](https://www.dell.com/learn/rail-rack-matrix).

The document provides the information that is listed below:

- Specific details about rail types and their functionalities.
- Rail adjustability range for various types of rack mounting flanges.
- Rail depth with and without cable management accessories.
- Types of racks supported for various types of rack mounting flanges.

# Technical specifications

The technical and environmental specifications of your system are outlined in this chapter.

**NOTE:** This document provides a comprehensive list of product features. However, features marked with an asterisk (\*) may not be available at launch but introduced in future updates. Please note that this document does not confirm the availability or release timeline of any feature. For the most accurate and up-to-date information on feature availability, please refer to the product configurator page on dell.com.

## Topics:

- Chassis I/O Configuration
- Chassis dimensions
- System weight
- Processor specifications
- Cooling fan specifications
- PSU specifications
- Supported operating system
- System battery specifications
- Expansion card riser specifications
- Memory specifications
- Storage controller specifications
- Drives
- GPU Specifications
- DPU Specifications
- Ports and connectors specifications
- Video specifications
- Environmental specifications

## Chassis I/O Configuration

Dell Servers offer choices for the location of Networking Interface and Systems Management cable connections.

**Rear I/O** (Input/Output) is the most common configuration. With Rear I/O network connections are at the rear of the Server. Systems management cables are connected at the rear by a dedicated port or a selectable shared port with a network interface controller. The power supplies and power cables are at the rear of the Server.



Figure 31. Rear I/O configurations

**NOTE:** Sample chassis configurations; these may not match your configuration.

**Front I/O** (Input/Output) is an option where PCIe risers and OCP network interface controllers are in the front of the Server. Systems management cables are connected at the front of the server by a dedicated port or a selectable shared port with a network interface controller. The power button and system status indicators are at the front of the Server.



Figure 32. Front I/O configurations

**NOTE:** Sample chassis configurations; these may not match your configuration.

Both configurations have their benefits, but the most common reason for choosing Front I/O is the desire to connect I/O and Systems Management cables to the front of the server. There are certain rack infrastructure products that take advantage of a front I/O location.

## Chassis dimensions

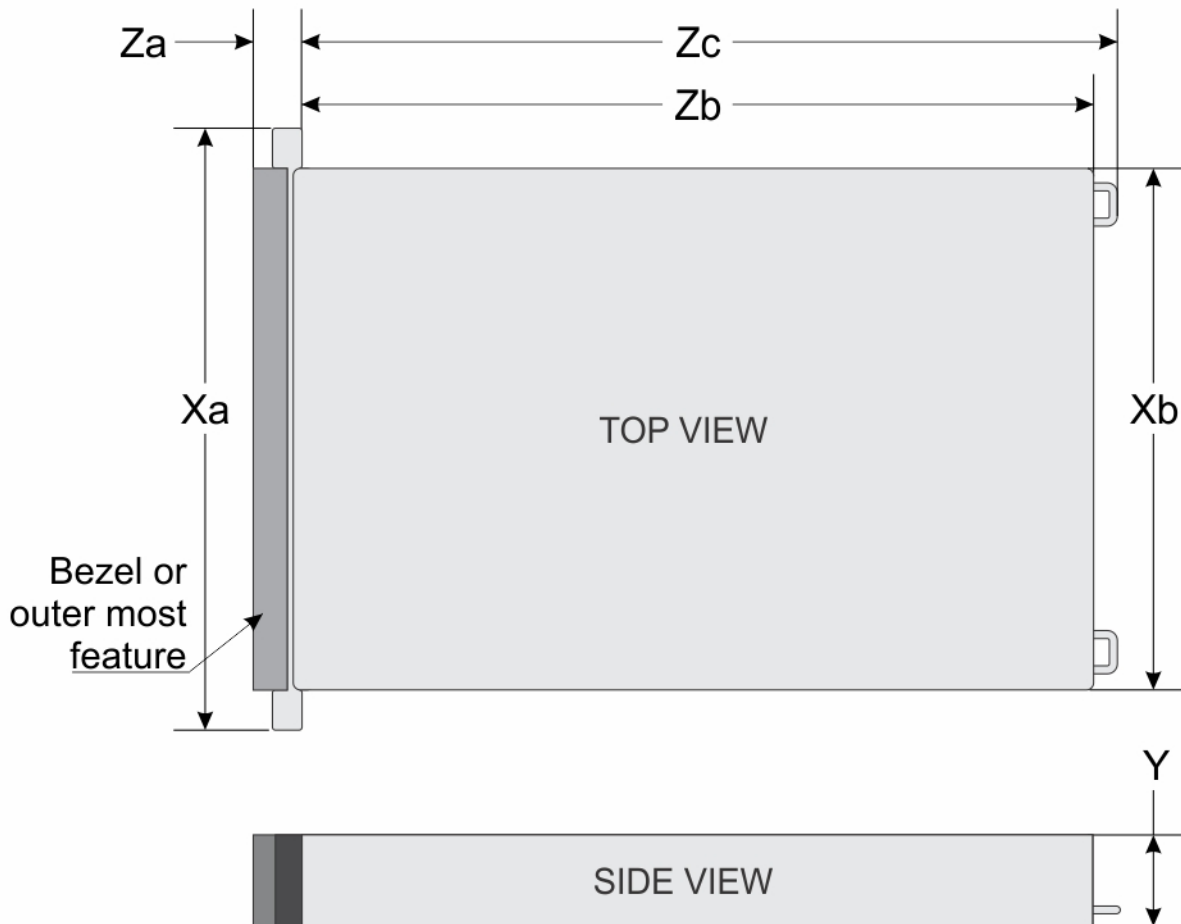

Figure 33. Chassis dimensions

Table 15. PowerEdge R670 chassis dimensions

Drives	Xa	Xb	Y	Za	Zb	Zc
8 drives x E3.S (Front I/O)	482.0 mm (18.98 inches)	434.0 mm (17.09 inches)	42.8 mm (1.69 inches)	43.3 mm (1.70 inches) Without bezel	750.57 mm (29.55 inches) Ear to rear wall	786.14 mm (30.95 inches) Ear to PSU handle
<ul style="list-style-type: none"> <li>8 x 2.5-inch with RIO</li> <li>10 x 2.5-inch with RIO</li> <li>16 x EDSFF E3.S drive</li> <li>20 x EDSFF E3.S drive</li> <li>0 Drives</li> </ul>	482.0 mm (18.98 inches)	434.0 mm (17.09 inches)	42.8 mm (1.69 inches)	30.78 mm (1.21 inches) with bezel 29 mm (1.14 inches) Without bezel	750.57 mm (29.55 inches) Ear to rear wall	786.14 mm (30.95 inches) Ear to PSU handle

**NOTE:** Zb is the nominal rear wall external surface where the system board I/O connectors reside.

## System weight

**Table 16. PowerEdge R670 system weight**

System configuration	Maximum weight (with all drives/SSDs)
8 x EDSFF E3.S	20.42 kg (45.02 pound)
8 x 2.5-inch SATA drives	19.26 kg (42.46 pound)
8 x 2.5-inch Universal	19.26 kg (42.46 pound)
10 x 2.5-inch SATA drives	19.7 kg (43.43 pound)
16 x EDSFF E3.S drives	19.58 kg (43.16 pound)
20 x EDSFF E3.S drives	20.18 kg (44.48 pound)
0 Drive	17.18 kg (37.87 pound)

**Table 17. PowerEdge R670 weight handling recommendations**

Chassis weight	Description
40–70 pounds	Recommend two people to lift.
70-120 pounds	Recommend three people to lift.
≥ 121 pounds	Recommend to use a server-lift.

## Processor specifications

**Table 18. PowerEdge R670 processor specifications**

Supported processor	Number of processors supported
Intel® Xeon® 6 E-Core processor	Two
Intel® Xeon® 6 P-Core processor	Two

**Table 19. Minimum Firmware version requirement for Intel® Xeon® 6 P-Core Processors**

Processors	iDRAC	BIOS	FPGA
6787P	1.20.25.00	1.2.6	107.114.104
6767P			
6760P			
6747P			
6740P			
6736P			
6737P			
6730P			
6530P			
6527P			
6520P			
6724P			



**Table 19. Minimum Firmware version requirement for Intel® Xeon® 6 P-Core Processors (continued)**

Processors	iDRAC	BIOS	FPGA
6517P			
6515P			
6505P			
6714P			
6507P			

## Cooling fan specifications

The PowerEdge R670 system supports up to 4 set high-performance silver (HPR SLVR) or Standard (STD) hot-swappable cooling fans, each consisting of a dual fan module.

**Table 20. Cooling fan specifications**

Fan type	Abbreviation	Label color	Label image
High performance Silver (HPR SLVR) fans	HPR SLVR	Silver	
Standard (STD) fans	STD	Standard	

**NOTE:** Cooling fans rotate at a slower speed, even while the system is in standby mode, and the fan speed varies in response to changes in the ambient temperature.

# PSU specifications

The PowerEdge R670 system supports up to two AC or DC power supply units (PSUs).

**Table 21. R670 PSU specifications**

PSU	Class	Heat dissipation (maximum) (BTU/hr)	Frequency (Hz)	AC Voltage			DC Voltage			Current (A)
				200—240 V	100—120 V	277 V	240 V	- (48—60) V	336 V	
800 W mixed mode	Platinum	3000	50/60	800 W	800 W	N/A	N/A	N/A	N/A	9.2—4.5
	N/A	3000	N/A	N/A	N/A	N/A	800 W	N/A	N/A	3.7
	Titanium	3000	50/60	800 W	800 W	N/A	N/A	N/A	N/A	9.2—4.5
	N/A	3000	N/A	N/A	N/A	N/A	800 W	N/A	N/A	3.7
1100 W mixed mode	Platinum	4125	50/60	1100 W	1050 W	N/A	N/A	N/A	N/A	12—6.1
	N/A	4125	N/A	N/A	N/A	N/A	1100 W	N/A	N/A	5.1
	Titanium	4125	50/60	1100 W	1050 W	N/A	N/A	N/A	N/A	12—6.1
	N/A	4125	N/A	N/A	N/A	N/A	1100 W	N/A	N/A	5.1
1400 W -48 VDC*	Titanium	5310	N/A	N/A	N/A	N/A	N/A	1400 W	N/A	33
1500 W mixed mode	Titanium	5625	50/60	1500 W	1050 W	N/A	N/A	N/A	N/A	12.1—8.2
	N/A	5625	N/A	N/A	N/A	N/A	1500 W	N/A	N/A	6.8
1500 W 277Vac & HVDC*	Titanium	5625	N/A	N/A	N/A	N/A	1500 W	N/A	N/A	6.8
1800 W HLAC Titanium*	Titanium	6750	50/60	1800 W	N/A	N/A	N/A	N/A	N/A	9.8—8.2
1800 W HVDC*	N/A	6750	N/A	N/A	N/A	N/A	1800 W	N/A	N/A	8.2

**NOTE:** PowerEdge R670 supports up to two mixed mode power supplies with non-redundancy (1+0, 2+0), as the iDRAC does not calculate system power consumption.

**NOTE:** Heat dissipation is calculated using the PSU wattage rating.

**NOTE:** When selecting or upgrading the system configuration, to ensure optimum power utilization, verify the system power consumption with the Enterprise Infrastructure Planning Tool available at [Dell.com/calc](http://Dell.com/calc).



**Figure 34. PSU power cords**

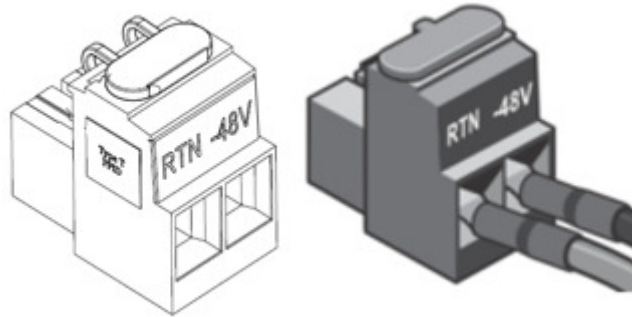

Figure 35. Lotes DC PSU connector

Table 22. PSU power cords

Form factor	Output	Power cord
60 mm	800 W Mixed Mode	C13
	1100 W Mixed Mode	C13
	1400 W -48 VDC*	Lotes RN5T2
	1500 W Mixed Mode	C13
	1800 W HLAC*	C13

**NOTE:** \*Feature not available at product launch in June, 2025. Please refer to the product configurator page on Dell.com to confirm feature availability.

## Supported operating system

The PowerEdge R670 system supports the following operating systems:

- Canonical Ubuntu Server LTS
- Microsoft Windows Server with Hyper-V
- Red Hat Enterprise Linux
- SUSE Linux Enterprise Server
- VMware ESXi
- Dell NativeEdge OS\*

**NOTE:** \*Features marked with an asterisk (\*) may not be available at product launch. Please refer to the product configurator page on Dell.com to confirm feature availability.

For specifications and interoperability details, see [OS support](#).

## System battery specifications

The PowerEdge R670 system uses one CR 2032 3.0-V lithium coin cell battery.

## Expansion card riser specifications

The PowerEdge R670 system supports up to two PCI express (PCIe) slots (Gen5 slots), OCP NIC and BOSS on the system board.

**Table 23. Expansion card slots supported on the system board**

PCIe slot	Expansion card riser	Processor connection	Height	Length	Slot width
Slot 1	R2b	Processor 1	Full Height	Half Length	x16
	R2c	Processor 1	Low Profile	Half Length	x16
	R2e	Processor 1	Low Profile	Half Length	x16
	R2f	Processor 1	Low Profile	Half Length	x16
Slot 2	R2c	Processor 1	Low Profile	Half Length	x16
	R2f (OCP)	Processor 1	N/A	N/A	x16
Slot 3	BOSS (Rear)	Processor 0	N/A	N/A	x4
Slot 4	R4b	Processor 0	Full Height	Half Length	x16
	R4a	Processor 0	Low Profile	Half Length	x16
Slot 5	OCP	Processor 0	N/A	N/A	x16
Slot 31	RF1a	Processor 0	Full Height	Half Length	x16
	RF1b (front OCP)	Processor 0	N/A	N/A	x16
Slot 32	RF1a (front Riser 1a)	Processor 1	Full Height	Half Length	x16
	RF1b (front OCP)	Processor 1	N/A	N/A	x16
Slot 34	BOSS (front)	Processor 0	N/A	N/A	x4

## Memory specifications

The PowerEdge R670 system supports the following memory specifications for optimized operation.

**Table 24. Memory specifications**

DIMM type	Rank	Capacity	Dual processors			
			Intel® Xeon 6 E- core processor		Intel® Xeon 6 P- core processor	
			Minimum system capacity	Maximum system capacity	Minimum system capacity	Maximum system capacity
RDIMM	1 R	16 GB	N/A	N/A	32 GB	256 GB
	2 R	32 GB	64 GB	512 GB	64 GB	1 TB
		64 GB	1 TB	2 TB	512 GB	2 TB
		96 GB	N/A	N/A	1.5 TB	3 TB
		128 GB	N/A	N/A	2 TB	4 TB
	8 R	256 GB	N/A	N/A	8 TB	8 TB

**NOTE:** Only 32 GB allowed for 1 DIMM per processor for E- core processors with limited features.

**NOTE:** Only 16 GB or 32 GB allowed for 1 DIMM per processor for P- core processors with limited features.

**NOTE:** Memory mirroring is supported only on P- core processors.

**NOTE:** Fault resilient mode (FRM) is supported only on P- core processors with 8 or 16 DIMMs per processor.

**Table 25. Memory module sockets**

Memory module sockets	Speed
32, 288-pin	6400 MT/s

- NOTE:** Memory DIMM slots are not hot pluggable.
- NOTE:** The processor may reduce the performance of the rated DIMM speed.
- NOTE:** DIMM mixing configurations are not allowed. All DIMM slots must be populated with the exact same DIMMs (one Dell PN).

## Storage controller specifications

The PowerEdge R670 system supports the following controller cards:

**Table 26. Storage controller cards**

Supported storage controller cards
Internal controllers: <ul style="list-style-type: none"><li>H965i Front DC-MHS</li><li>H365i Front DC-MHS</li><li>H975i Front DC-MHS</li></ul>
External controllers <ul style="list-style-type: none"><li>H965e</li><li>HBA465e</li></ul>
Internal Boot <ul style="list-style-type: none"><li>Boot Optimized Storage Subsystem (BOSS-N1 DC-MHS): HWRAID 1, 2 x M.2 NVMe SSDs or</li><li>M.2 Interposer board (DC-MHS): 2 x M.2 NVMe SSDs or</li><li>USB</li></ul>
Software RAID: N/A
SAS Hot Bus Adapters (HBA): HBA465e

- NOTE:** For the ESXi operating system, H975i is supported on 9.0 or later versions.

## Drives

The PowerEdge R670 system supports:

- Up to 8 x EDSFF E3.S NVMe drives
- Up to 16 x EDSFF E3.S NVMe drives
- Up to 20 x EDSFF E3.S NVMe drives
- Up to 2 x EDSFF E3.S NVMe drives in the rear
- Up to 8 x 2.5-inch SAS/SATA/ NVMe drives
- Up to 8 x 2.5-inch Universal drives
- Up to 10 x 2.5-inch SAS/SATA drives

- NOTE:** For more information about how to hot swap NVMe PCIe SSD device, see the *Dell Express Flash NVMe PCIe SSD User's Guide* at [Dell Support](#) page > **Browse all products > Infrastructure > Data Center Infrastructure > Storage Adapters & Controllers > Dell PowerEdge Express Flash NVMe PCIe SSD > Select This Product > Documentation > Manuals and Documents.**

# GPU Specifications

The PowerEdge R670 system supports

- Up to three NVIDIA L4 24 GB 72 W single-width GPUs

**NOTE:** The system supports up to 75 W of PCIe slot power without the use of an extra auxiliary power cable.

# DPU Specifications

The PowerEdge R670 platform accommodates Data Processing Units (DPUs). These units are system-on-chip solutions that combine ARM cores, high-performance NICs, and programmable acceleration engines to offload and accelerate data center infrastructure services.

**Table 27. Supported Data Processing Units(DPU) Cards**

Feature	NVIDIA BlueField-3 2 x 200 GbE B3220	NVIDIA BlueField-3 1 x 400 GbE B3140H
Type	Data Processing Units (DPU)	Data Processing Units (DPU)
Networking	2 x 200 GbE	1 x 400 GbE
Form Factor	FHHL	FHHL
Interface	PCIe Gen5 x16	PCIe Gen5 x16
Power Consumption	150 W	75 W
Compatible Risers	RC 1 (Slots 31,32), RC 5 (Slots 4,1)	RC 1 (Slots 31,32), RC 5 (Slots 4,1)

# Ports and connectors specifications

## NIC port specifications

The PowerEdge R670 system supports Network Interface Controller (NIC) ports embedded on the Open Compute Project (OCP) NIC cards.

**Table 28. NIC port specification for the system**

Feature	Specifications
OCP NIC 3.0 card	1 GbE x 4, 10 GbE x 2, 10 GbE x 4, 25 GbE x 2, 25 GbE x 4, 100 GbE x 2

**NOTE:** The OCP NIC card is installed at the front or rear of the system, depending on the system I/O configuration.

## Serial connector specifications

The PowerEdge R670 system system supports one optional card type serial connector, which is a 9-pin connector, Data Terminal Equipment (DTE), 16550-compliant .

The optional serial connector card is available only in front I/O configuration.

Top USB port on DC-SCM supports external DB9 Dongle.

## USB ports specifications

**Table 29. PowerEdge R670 USB specifications**

Front		Rear		Internal (Optional)	
USB port type	No. of ports	USB port type	No. of ports	USB port type	No. of ports
USB 2.0-compliant port	One (optional)	USB 3.1-compliant ports	Two	Internal USB 3.1-compliant port	One
USB 2.0 Type C port	One				

## VGA ports specifications

The PowerEdge R670 system supports DB-15 VGA port on the rear I/O Datacenter Secure Control Module (DC-SCM).

## Video specifications

The PowerEdge R670 system supports integrated Matrox G200 graphics controller with 16 MB of video frame buffer.

**Table 30. Supported video resolution options**

Resolution	Refresh rate (Hz)	Color depth (bits)
1024 x 768	60	8, 16, 32
1280 x 800	60	8, 16, 32
1280 x 1024	60	8, 16, 32
1360 x 768	60	8, 16, 32
1440 x 900	60	8, 16, 32
1600 x 900	60	8, 16, 32
1600 x 1200	60	8, 16, 32
1680 x 1050	60	8, 16, 32
1920 x 1080	60	8, 16, 32
1920 x 1200	60	8, 16, 32

## Environmental specifications

**NOTE:** For additional information about environmental certifications, refer to the **Product Environmental Datasheet** located with the **Manuals & Documents** on [Dell Support](#).

**Table 31. Continuous Operation Specifications for ASHRAE A2**

Operational/non-operational conditions	Allowable operations
Maximum temperature gradient (applies to both operation and non-operation)	20 °C in an hour* (36 °F in an hour) and 5 °C in 15 minutes (9 °F in 15 minutes), 5 °C in an hour* (9 °F in an hour) for tape hardware.
Non-operational temperature limits	-40(-5)** to 65 °C (-40(23)** to 149 °F)
Non-operational humidity limits (non-condensing at all times)	5% to 95% RH with 27 °C (80.6 °F) maximum dew point.
Maximum non-operational altitude	12,000 meters (39,370 feet)

**Table 31. Continuous Operation Specifications for ASHRAE A2 (continued)**

Operational/non-operational conditions	Allowable operations
Maximum operational altitude	3050 meters (10,006 feet)
Battery storage	See appendix C

**NOTE:** \* Per ASHRAE thermal guidelines, these are not instantaneous rates of temperature change.

**NOTE:** \*\* Liquid filled components, or systems/solutions containing liquid filled components are limited to approximately 5 °C above their freeze point. At this time, the only authorized liquid coolant is Recochem PG25 with a freeze point between -9 °C and -13 °C, therefore the lower non-operational temperature limit is -5 °C. Components and systems/solutions that can contain liquid but do not at the time of testing shall be tested to the -40 °C lower non-operational temperature limit.

**Table 32. Maximum vibration specifications**

Maximum vibration	Specifications
Operating	0.21 G <sub>rms</sub> at 5 Hz to 500 Hz (all operation orientations)
Storage	1.38 G <sub>rms</sub> at 7 Hz to 250 Hz for 15 minutes (all six sides tested)

**Table 33. Maximum shock pulse specifications**

Maximum shock pulse	Specifications
Operating	Six consecutively executed shock pulses in the positive and negative x, y, and z axis of 6 G for up to 11 ms.
Storage	Six consecutively executed shock pulses in the positive and negative x, y, and z axis (one pulse on each side of the system) of 71 G for up to 2 ms.

## Thermal restriction matrix

**Table 34. Label reference**

Label	Description
STD	Standard
HPR (Silver)	High performance Silver (HPR SLVR) fan
HPR (Gold)	High performance Gold (HPR GOLD) fan
HSK	Heat sink
L-Type	L-shaped
LP	Low profile
FH	Full height
EXT	Extend

**Table 35. Processor and heat sink matrix**

Heat sink	Processor TDP
1U EXT HSK	< 270 W
L-type HSK	≥ 270 W

**NOTE:** The configuration's ambient temperature is dictated by its critical component. For example, if the processor's ambient temperature is 35°C, the DIMM is 35°C, and the GPU is 30°C, the configuration's ambient temperature can only be 30°C.

**NOTE:** Both Front I/O and Rear I/O configurations are supported, using the same chassis.

**Table 36. Thermal restriction matrix**

Configuration			No BP	FIO 8 x E3.s		8 x 2.5-inch SmartFlow		10 x 2.5-inch	16 x E3.s	20 x E3.s		Ambient temperature	
Storage configuration number			C0-02	C01-01, C01-02		C02-01, C02-02, C02-03, C02-05, C02-06, C02-08, C02-09		C03-01, C03-02, C03-04, C03-05	C04-01, C04-02, C04-03	C05-01	C05-03 (with rear E3.s)		
Riser configuration			Any	RC5, RC6, RC3, RC4	RC1, RC2	RC5, RC6, RC8	No riser (RC0)	Any	Any	Any	RC10		
Processor	TDP	Cores	E- core processors										
6710E	205 W	64	STD Fan EXT HSK	STD Fan EXT HSK	STD Fan EXT HSK	STD Fan EXT HSK	STD Fan EXT HSK	STD Fan EXT HSK	STD Fan EXT HSK	STD Fan EXT HSK	STD Fan EXT HSK	HPR Silver Fan EXT HSK	35°C
6756E	225 W	128	HPR Silver Fan EXT HSK	HPR Silver Fan EXT HSK	HPR Silver Fan EXT HSK	HPR Silver Fan EXT HSK	HPR Silver Fan EXT HSK	HPR Silver Fan EXT HSK	HPR Silver Fan EXT HSK	HPR Silver Fan EXT HSK	HPR Silver Fan EXT HSK	HPR Silver Fan EXT HSK	35°C
6740E	250 W	96	HPR Silver Fan EXT HSK	HPR Silver Fan EXT HSK	HPR Silver Fan EXT HSK	HPR Silver Fan EXT HSK	HPR Silver Fan EXT HSK	HPR Silver Fan EXT HSK	HPR Silver Fan EXT HSK	HPR Silver Fan EXT HSK	HPR Silver Fan EXT HSK 30°C	HPR Silver Fan EXT HSK 30°C	35°C
6746E	250 W	112	HPR Silver Fan EXT HSK	HPR Silver Fan EXT HSK	HPR Silver Fan EXT HSK	HPR Silver Fan EXT HSK	HPR Silver Fan EXT HSK	HPR Silver Fan EXT HSK	HPR Silver Fan EXT HSK	HPR Silver Fan EXT HSK	HPR Silver Fan EXT HSK 30°C	HPR Silver Fan EXT HSK 30°C	35°C
6766E	250 W	144	HPR Silver Fan EXT HSK	HPR Silver Fan EXT HSK	HPR Silver Fan EXT HSK	HPR Silver Fan EXT HSK	HPR Silver Fan EXT HSK	HPR Silver Fan EXT HSK	HPR Silver Fan EXT HSK	HPR Silver Fan EXT HSK	HPR Silver Fan EXT HSK 30°C	HPR Silver Fan EXT HSK 30°C	35°C
6780E	330 W	144	HPR Silver Fan L-Type HSK	HPR Silver Fan L-Type HSK	HPR Silver Fan L-Type HSK	HPR Silver Fan L-Type HSK	HPR Silver Fan L-Type HSK	HPR Silver Fan L-Type HSK	HPR Silver Fan L-Type HSK 30°C	HPR Silver Fan L-Type HSK 30°C	Requires DLC	Requires DLC	35°C
P- core processors													
6507P	150 W	8	STD Fan STD HSK	STD Fan STD HSK	STD Fan STD HSK	STD Fan STD HSK	STD Fan STD HSK	STD Fan STD HSK	STD Fan STD HSK	STD Fan STD HSK	STD Fan STD HSK	HPR Silver Fan STD HSK	35°C

**Table 36. Thermal restriction matrix (continued)**

Configuration			No BP	FIO 8 x E3.s		8 x 2.5-inch SmartFlow		10 x 2.5-inch	16 x E3.s	20 x E3.s		Ambient temperature	
Storage configuration number			C0-02	C01-01, C01-02		C02-01, C02-02, C02-03, C02-05, C02-06, C02-08, C02-09		C03-01, C03-02, C03-04, C03-05	C04-01, C04-02, C04-03	C05-01	C05-03 (with rear E3.s)		
Riser configuration			Any	RC5, RC6, RC3, RC4	RC1, RC2	RC5, RC6, RC8	No riser (RC0)	Any	Any	Any	RC10		
Processor	TDP	Cores	E- core processors										
6505P	150 W	12	STD Fan STD HSK	STD Fan STD HSK	STD Fan STD HSK	STD Fan STD HSK	STD Fan STD HSK	STD Fan STD HSK	STD Fan STD HSK	STD Fan STD HSK	STD Fan STD HSK	HPR Silver Fan STD HSK	35°C
6515P	150 W	16	STD Fan STD HSK	STD Fan STD HSK	STD Fan STD HSK	STD Fan STD HSK	STD Fan STD HSK	STD Fan STD HSK	STD Fan STD HSK	STD Fan STD HSK	STD Fan STD HSK	HPR Silver Fan STD HSK	35°C
6714P	165 W	8	STD Fan STD HSK	STD Fan STD HSK	STD Fan STD HSK	STD Fan STD HSK	STD Fan STD HSK	STD Fan STD HSK	STD Fan STD HSK	STD Fan STD HSK	STD Fan STD HSK	HPR Silver Fan STD HSK	35°C
6517P	190 W	16	STD Fan EXT HSK	STD Fan EXT HSK	STD Fan EXT HSK	STD Fan EXT HSK	STD Fan EXT HSK	STD Fan EXT HSK	STD Fan EXT HSK	STD Fan EXT HSK	STD Fan EXT HSK	HPR Silver Fan EXT HSK	35°C
6736P	205 W	36	STD Fan EXT HSK	STD Fan EXT HSK	STD Fan EXT HSK	STD Fan EXT HSK	STD Fan EXT HSK	STD Fan EXT HSK	STD Fan EXT HSK	STD Fan EXT HSK	STD Fan EXT HSK	HPR Silver Fan EXT HSK	35°C
6724P	210 W	16	STD Fan EXT HSK	STD Fan EXT HSK	STD Fan EXT HSK	STD Fan EXT HSK	STD Fan EXT HSK	STD Fan EXT HSK	STD Fan EXT HSK	STD Fan EXT HSK	STD Fan EXT HSK	HPR Silver Fan EXT HSK	35°C
6520P	210 W	24	STD Fan EXT HSK	STD Fan EXT HSK	STD Fan EXT HSK	STD Fan EXT HSK	STD Fan EXT HSK	STD Fan EXT HSK	STD Fan EXT HSK	STD Fan EXT HSK	STD Fan EXT HSK	HPR Silver Fan EXT HSK	35°C
6530P	225 W	32	HPR Silver Fan EXT HSK	HPR Silver Fan EXT HSK	HPR Silver Fan EXT HSK	HPR Silver Fan EXT HSK	HPR Silver Fan EXT HSK	HPR Silver Fan EXT HSK	HPR Silver Fan EXT HSK	HPR Silver Fan EXT HSK	HPR Silver Fan EXT HSK	HPR Silver Fan EXT HSK	35°C

**Table 36. Thermal restriction matrix (continued)**

Configuration			No BP	FIO 8 x E3.s		8 x 2.5-inch SmartFlow		10 x 2.5-inch	16 x E3.s	20 x E3.s		Ambient temperature	
Storage configuration number			C0-02	C01-01, C01-02		C02-01, C02-02, C02-03, C02-05, C02-06, C02-08, C02-09		C03-01, C03-02, C03-04, C03-05	C04-01, C04-02, C04-03	C05-01	C05-03 (with rear E3.s)		
Riser configuration			Any	RC5, RC6, RC3, RC4	RC1, RC2	RC5, RC6, RC8	No riser (RC0)	Any	Any	Any	RC10		
Processor	TDP	Cores	E-core processors										
6730P	250 W	32	HPR Silver Fan EXT HSK	HPR Silver Fan EXT HSK	HPR Silver Fan EXT HSK	HPR Silver Fan EXT HSK	HPR Silver Fan EXT HSK	HPR Silver Fan EXT HSK	HPR Silver Fan EXT HSK	HPR Silver Fan EXT HSK	HPR Silver Fan EXT HSK 30°C	HPR Silver Fan EXT HSK 30°C	35°C
6527P	225 W	24	HPR Silver Fan EXT HSK	HPR Silver Fan EXT HSK	HPR Silver Fan EXT HSK	HPR Silver Fan EXT HSK	HPR Silver Fan EXT HSK	HPR Silver Fan EXT HSK	HPR Silver Fan EXT HSK	HPR Silver Fan EXT HSK	HPR Silver Fan EXT HSK 30°C	HPR Silver Fan EXT HSK 30°C	35°C
6737P	270 W	32	HPR Silver Fan L-Type HSK	HPR Silver Fan L-Type HSK	HPR Silver Fan L-Type HSK	HPR Silver Fan L-Type HSK	HPR Silver Fan L-Type HSK	HPR Silver Fan L-Type HSK	HPR Silver Fan L-Type HSK 30°C	HPR Silver Fan L-Type HSK 30°C	HPR Silver Fan L-Type HSK 30°C	Requires DLC	35°C
6740P	270 W	48	HPR Silver Fan L-Type HSK	HPR Silver Fan L-Type HSK	HPR Silver Fan L-Type HSK	HPR Silver Fan L-Type HSK	HPR Silver Fan L-Type HSK	HPR Silver Fan L-Type HSK	HPR Silver Fan L-Type HSK 30°C	HPR Silver Fan L-Type HSK 30°C	HPR Silver Fan L-Type HSK 30°C	Requires DLC	35°C
6760P	330 W	64	HPR Silver Fan L-Type HSK	HPR Silver Fan L-Type HSK	HPR Silver Fan L-Type HSK	HPR Silver Fan L-Type HSK	HPR Silver Fan L-Type HSK	HPR Silver Fan L-Type HSK	HPR Silver Fan L-Type HSK 30°C	HPR Silver Fan L-Type HSK 30°C	Requires DLC	Requires DLC	35°C
6747P	330 W	48	HPR Silver Fan L-Type HSK	HPR Silver Fan L-Type HSK	HPR Silver Fan L-Type HSK	HPR Silver Fan L-Type HSK	HPR Silver Fan L-Type HSK	HPR Silver Fan L-Type HSK	HPR Silver Fan L-Type HSK 30°C	HPR Silver Fan L-Type HSK 30°C	Requires DLC	Requires DLC	35°C
6767P	350 W	64	HPR Silver Fan L-Type HSK	HPR Silver Fan L-Type HSK 30°C	HPR Silver Fan L-Type HSK	HPR Silver Fan L-Type HSK	HPR Silver Fan L-Type HSK	HPR Silver Fan L-Type HSK	Requires DLC	Requires DLC	Requires DLC	Requires DLC	35°C

**Table 36. Thermal restriction matrix (continued)**

Configuration			No BP	FIO 8 x E3.s			8 x 2.5-inch SmartFlow		10 x 2.5-inch	16 x E3.s	20 x E3.s		Ambient temperature
Storage configuration number			C0-02	C01-01, C01-02			C02-01, C02-02, C02-03, C02-05, C02-06, C02-08, C02-09		C03-01, C03-02, C03-04, C03-05	C04-01, C04-02, C04-03	C05-01	C05-03 (with rear E3.s)	
Riser configuration			Any	RC5, RC6, RC3, RC4	RC1, RC2	RC5, RC6, RC8	No riser (RC0)	Any	Any	Any	RC10		
Processor	TDP	Cores	E-core processors										
6787P	350 W	86	HPR Silver Fan L-Type HSK	HPR Silver Fan L-Type HSK 30°C	HPR Silver Fan L-Type HSK	HPR Silver Fan L-Type HSK 30°C	HPR Silver Fan L-Type HSK	Requires DLC	Requires DLC	Requires DLC	Requires DLC	35°C	

**Table 37. Thermal restriction matrix for L4 GPU**

Configuration		No BP	FIO 8 x E3.s			8 x 2.5-inch SmartFlow		10 x 2.5-inch	16 x E3.s	20 x E3.s	
Storage configuration number		C0-02	C01-01, C01-02			C02-01, C02-02, C02-03, C02-05, C02-06, C02-08, C02-09		C03-01, C03-02, C03-04, C03-05	C04-01, C04-02, C04-03	C05-01	C05-03 (with rear E3.s)
Riser configuration		Any	RC5, RC6, RC3, RC4	RC1, RC2	RC5, RC6, RC8	No riser (RC0)	Any	Any	Any	RC10	
L4 GPU		35°C	35°C	35°C	35°C	35°C	CPU>225 W Restricted 30°C ambient	35°C	Restricted 30°C ambient	Restricted 30°C ambient	

**Table 38. Thermal restriction for NVIDIA B3220 DPU**

Configuration		FIO 8 x E3.s		8 x 2.5-inch SmartFlow		10 x 2.5-inch	16 x E3.s	20 x E3.s	
Storage configuration number		C01-01, C01-02		C02-01, C02-02, C02-03, C02-05, C02-06, C02-08, C02-09		C03-01, C03-02, C03-04, C03-05	C04-01, C04-02	C05-01	
Riser configuration		RC5	RC1, RC4 (in slot 31, 32 only)	RC5		RC5	RC5	RC5	
B3220 DPU w/ Active Transceivers		Restricted 30°C ambient	35°C	Restricted 30°C ambient		Not supported	Not supported	Not supported	
		CPU>270 W are not supported		CPU>270 W are not supported					

**Table 38. Thermal restriction for NVIDIA B3220 DPU (continued)**

Configuration	FIO 8 x E3.s		8 x 2.5-inch SmartFlow	10 x 2.5-inch	16 x E3.s	20 x E3.s
Storage configuration number	C01-01, C01-02		C02-01, C02-02, C02-03, C02-05, C02-06, C02-08, C02-09	C03-01, C03-02, C03-04, C03-05	C04-01, C04-02	C05-01
Riser configuration	RC5	RC1, RC4 (in slot 31, 32 only)	RC5	RC5	RC5	RC5
B3220 DPU w/ Passive Cable (DAC)	35°C	35°C	35°C	35°C	35°C	35°C

**Table 39. Thermal restriction for NVIDIA B3140H DPU**

Configuration	FIO 8 x E3.s		8 x 2.5-inch SmartFlow	10 x 2.5-inch	16 x E3.s	20 x E3.s
Storage configuration number	C01-01, C01-02		C02-01, C02-02, C02-03, C02-05, C02-06, C02-08, C02-09	C03-01, C03-02, C03-04, C03-05	C04-01, C04-02	C05-01
Riser configuration	RC5	RC1, RC4 (in slot 31, 32 only)	RC5	RC5	RC5	RC5
B3140H DPU w/ Active Transceivers	Not supported	35°C	Not supported	Not supported	Not supported	Not supported
B3140H DPU w/ Passive Cable (DAC)	35°C	35°C	35°C	35°C	35°C	35°C

**Table 40. Thermal restriction for NVIDIA B3220 DPU with DLC**

Configuration	8 x 2.5-inch SmartFlow	10 x 2.5-inch	16 x E3.s	20 x E3.s
Storage configuration number	C02-01, C02-02, C02-03, C02-05, C02-06, C02-08, C02-09	C03-01, C03-02, C03-04, C03-05	C04-01, C04-02	C05-01
Riser configuration	RC5	RC5	RC5	RC5
B3220 DPU w/ Active Transceivers	35°C	30°C	35°C	Not supported
B3220 DPU w/ Passive Cable (DAC)	35°C	35°C	35°C	35°C

**Table 41. Thermal restriction for NVIDIA B3140H DPU with DLC**

Configuration	8 x 2.5-inch SmartFlow	10 x 2.5-inch	16 x E3.s	20 x E3.s
Storage configuration number	C02-01, C02-02, C02-03, C02-05, C02-06, C02-08, C02-09	C03-01, C03-02, C03-04, C03-05	C04-01, C04-02	C05-01
Riser configuration	RC5	RC5	RC5	RC5
B3140H DPU w/ Active Transceivers	Not supported	Not supported	Not supported	Not supported
B3140H DPU w/ Passive Cable (DAC)	35°C	35°C	35°C	35°C

## Other Restrictions

**NOTE:** No thermal restriction to support all CPU SKUs with liquid cooling configurations.

- For rear IO configurations (RC3/ RC4/ RC5/ RC6/ RC8/ RC9/ RC10), PCIe/OCP cards with speeds of 25 Gb and above require DAC or high temp spec (85C) active optics.

## Particulate and gaseous contamination specifications

The following table defines the limitations that help avoid any equipment damage or failure from particulates and gaseous contamination. If the levels of particulates or gaseous pollution exceed the specified limitations and result in equipment damage or failure, you must rectify the environmental conditions. Remediation of environmental conditions is the responsibility of the customer.

**Table 42. Particulate contamination specifications**

Particulate contamination	Specifications
Air filtration: Conventional Data Center only	Data center air filtration as defined by ISO Class 8 per ISO 14644-1 with a 95% upper confidence limit <b>NOTE:</b> Filtering room air with a MERV8 filter, as specified in ANSI/ASHRAE Standard 127, is a recommended method for achieving the necessary environmental conditions. <b>NOTE:</b> Air entering the data center must have MERV11 or MERV13 filtration. <b>NOTE:</b> This condition applies to data center environments only. Air filtration requirements do not apply to IT equipment designed to be used outside a data center, in environments such as an office or factory floor.
Walk-Up Edge Data Center or Cabinet (sealed, closed loop environment)	Filtration is not required for cabinets that are anticipated to be opened six times or less per year. Class 8 per ISO 1466-1 filtration as defined above is required otherwise. <b>NOTE:</b> In environments commonly above ISA-71 Class G1 or that may have known challenges, special filters may be required.
Conductive dust: data center and non-data center environments	Air must be free of conductive dust, zinc whiskers, or other conductive particles. <b>NOTE:</b> Conductive dust, which can interfere with equipment operation, can originate from various sources, including manufacturing processes and zinc whiskers that may develop on the plating of raised floor tiles. <b>NOTE:</b> This condition applies to data center and non-data center environments.
Corrosive dust: data center and non-data center environments	<ul style="list-style-type: none"> <li>Air must be free of corrosive dust.</li> <li>Residual dust present in the air must have a deliquescent point less than 60% relative humidity.</li> </ul> <b>NOTE:</b> This condition applies to data center and non-data center environments.

**Table 43. Gaseous contamination specifications**

Gaseous contamination	Specifications	Notes
Copper coupon corrosion rate	ISA-71 Class G1: <300 Å/month	Per ANSI/ISA71.04
Silver coupon corrosion rate	ISA-71 Class G1: <200 Å/month	Per ANSI/ISA71.04

# Initial system setup and configuration

This section describes the tasks for initial setup and configuration of the Dell system. The section also provides general steps to set up the system and the reference guides for detailed information.

## Topics:

- [Setting up the system](#)
- [iDRAC configuration](#)
- [Resources to install operating system](#)

## Setting up the system

Perform the following steps to set up the system:

### Steps

1. Unpack the system.
2. Install the system into the rack. For more information, see the rail installation and cable management accessory guides relevant to your rail and cable management solution at [PowerEdge Manuals](#).
3. Connect the peripherals to the system and the system to the electrical outlet.
4. Power on the system.

For more information about setting up the system, see the *Getting Started Guide* that is shipped with your system.

 **NOTE:** For information about managing the basic settings and features of the system, see the [Pre-operating system management applications](#) chapter.

## iDRAC configuration

The Integrated Dell Remote Access Controller (iDRAC) is designed to make you more productive as a system administrator and improve the overall availability of Dell servers. iDRAC alerts you to system issues, helps you to perform remote management, and reduces the need for physical access to the system.

### Options to set up iDRAC IP address

To enable communication between your system and iDRAC, you must first configure the network settings based on your network infrastructure. The network settings option is set to **DHCP**, by default.



 **NOTE:** For static IP configuration, you must request for the settings at the time of purchase.

You can set up the iDRAC IP address using one of the interfaces in the table below. For information about setting up an iDRAC IP address, see the documentation links provided in the table below.

**Table 44. Interfaces to set up iDRAC IP address**

Interface	Documentation links
iDRAC Settings utility	Integrated Dell Remote Access Controller User's Guide at <a href="#">iDRAC Manuals</a> or for system specific Integrated Dell Remote Access Controller User's Guide, go to <a href="#">PowerEdge Manuals</a> > <b>Product Support</b> page of your system > <b>Documentation</b> .

**Table 44. Interfaces to set up iDRAC IP address (continued)**

Interface	Documentation links
	<p> <b>NOTE:</b> To determine the most recent iDRAC release for your platform and for latest documentation version, see KB article <a href="#">KB305325</a>.</p>
iDRAC Direct	<p>Integrated Dell Remote Access Controller User's Guide at <a href="#">iDRAC Manuals</a> or for system specific Integrated Dell Remote Access Controller User's Guide, go to <a href="#">PowerEdge Manuals &gt; Product Support</a> page of your system &gt; <b>Documentation</b>.</p> <p> <b>NOTE:</b> To determine the most recent iDRAC release for your platform and for latest documentation version, see KB article <a href="#">KB305325</a>.</p>
iDRAC Direct and Quick Sync 2 (optional)	<p>Integrated Dell Remote Access Controller User's Guide at <a href="#">iDRAC Manuals</a> or for system specific Integrated Dell Remote Access Controller User's Guide, go to <a href="#">PowerEdge Manuals &gt; Product Support</a> page of your system &gt; <b>Documentation</b>.</p> <p> <b>NOTE:</b> To determine the most recent iDRAC release for your platform and for latest documentation version, see KB article <a href="#">KB305325</a>.</p>

 **NOTE:** To access iDRAC, ensure that you connect the ethernet cable to the iDRAC dedicated network port or use the iDRAC Direct port by using a USB to Type C cable.

## Options to log in to iDRAC

To log in to the iDRAC Web User Interface, open a browser and enter the IP address.

You can log in to iDRAC as:

- iDRAC user
- Microsoft Active Directory user
- Lightweight Directory Access Protocol (LDAP) user

In the login screen displayed, if you have opted for secure default access to iDRAC, the default username is `root` and enter the iDRAC secure default password available on back of the Information Tag. If you opted for legacy password, use the iDRAC legacy username and password - `root` and `calvin`, the iDRAC default password will be blank on the information tag. Then you will be prompted and required to create a password of your choice before proceeding. You can also log in by using your Single Sign-On or Smart Card.

 **NOTE:** Ensure that you change the default username and password after setting up the iDRAC IP address.

For more information about logging in to the iDRAC and iDRAC licenses, see the latest [Integrated Dell Remote Access Controller User's Guide](#)

 **NOTE:** To determine the most recent iDRAC release for your platform and for latest documentation version, see KB article [KB305325](#).

You can also access iDRAC using command-line protocol - RACADM. For more information, see the [Integrated Dell Remote Access Controller RACADM CLI Guide](#).

You can also access iDRAC using automation tool - Redfish API. For more information, see the [Integrated Dell Remote Access Controller User's Guide Redfish API Guide](#).

## Resources to install operating system

If the system is shipped without an operating system, you can install a supported operating system by using one of the in the table below. For information about how to install the operating system, see the documentation links provided in the table below.

**Table 45. Resources to install the operating system**

Resource	Documentation links
iDRAC	<a href="#">Integrated Dell Remote Access Controller User's Guide</a> or for system-specific <a href="#">Integrated Dell Remote Access Controller User's Guide</a> , go to <a href="#">PowerEdge Manuals</a> > <b>Product Support</b> page of your system > <b>Documentation</b> . <b>NOTE:</b> To determine the most recent iDRAC release for your platform and for the latest documentation version, see KB article at <a href="#">KB305325</a> .

**NOTE:** For more information about installation and how-to videos for operating systems that are supported on PowerEdge systems, see [Supported Operating Systems for Dell PowerEdge systems](#).

## Options to download drivers and firmware

You can download the firmware from the Dell support site. For information about downloading firmware, see the [Downloading drivers and firmware](#) section.

You can also choose any one of the following options to download the firmware. For information about how to download the firmware, see the documentation links provided in the table below.

**Table 46. Options to download firmware**

Option	Documentation link
Using Integrated Dell Remote Access Controller (iDRAC)	<a href="#">iDRAC Manuals</a>
Using iDRAC virtual media	<a href="#">iDRAC Manuals</a>

## Options to download and install OS drivers

You can choose any one of the following options to download and install OS drivers. For information about how to download or install OS drivers, see the documentation links provided in the table below.

**Table 47. Options to download and install OS drivers**

Option	Documentation
Dell support site	<a href="#">Downloading drivers and firmware</a> section.
iDRAC virtual media	<a href="#">Integrated Dell Remote Access Controller User's Guide</a> or for system specific, go to <a href="#">Integrated Dell Remote Access Controller User's Guide</a> > <b>Product Support</b> page of your system > <b>Documentation</b> . <b>NOTE:</b> To determine the most recent iDRAC release for your platform and for the latest documentation version, see <a href="#">Integrated Dell Remote Access Controller Release Notes</a> .

## Downloading drivers and firmware

It is recommended that you download and install the latest BIOS, drivers, and systems management firmware on the system.

### Prerequisites

Ensure that you clear the web browser cache before downloading the drivers and firmware.

### Steps

1. Go to [Drivers](#).
2. Enter the Service Tag of the system in the **Enter a Dell Service Tag, Dell Product ID or Model** field, and then press Enter.

 **NOTE:** If you do not have the Service Tag, click **Browse all products**, and navigate to your product.

3. On the displayed product page, click **Drivers & Downloads**.  
On the **Drivers & Downloads** page, all drivers that are applicable to the system are displayed.
4. Download the drivers to a USB drive, CD, or DVD.

# Pre-operating system management applications

You can manage basic settings and features of a system without booting to the operating system by using the system firmware.

## Options to manage the pre-operating system applications

You can use any one of the following options to manage the pre-operating system applications:

- System Setup
- Boot Manager
- Preboot Execution Environment (PXE)

### Topics:

- [System Setup](#)
- [Boot Manager](#)
- [PXE boot](#)

## System Setup

Using the **System Setup** option, you can configure the BIOS settings, iDRAC settings, and device settings of the system.

You can access system setup by using any one of the following interfaces:

- Graphical User interface — To access go to iDRAC Dashboard, click **Configurations > BIOS Settings**.
- Text browser — To enable the text browser, use the Console Redirection.

To view

**System Setup**, power on the system, press F2, and click **System Setup Main Menu**.

**NOTE:** If the operating system begins to load before you press F2, wait for the system to finish booting, and then restart the system and try again.

The options on the

**System Setup Main Menu** screen are described in the following table:

**Table 48. System Setup Main Menu**

Option	Description
<b>System BIOS</b>	Enables you to configure the BIOS settings.
<b>iDRAC Settings</b>	Enables you to configure the iDRAC settings. The iDRAC utility is an interface to set up and configure the iDRAC parameters . You can enable or disable various iDRAC parameters by using the iDRAC utility. For more information about this utility, <i>Integrated Dell Remote Access Controller User's Guide</i> at <a href="#">PowerEdge Manuals</a> .
<b>Device Settings</b>	Enables you to configure device settings for devices such as storage controllers or network cards.
<b>Service Tag Settings</b>	Enables you to configure the System Service Tag.

# System BIOS

See the common options of the System BIOS here: [Support for General Solution Resources | Documentation | Dell US > Manuals and Documents > Set up BIOS on 17th Generation Dell PowerEdge Servers.](#)

## iDRAC Settings

The iDRAC settings is an interface to set up and configure the iDRAC parameters by using UEFI. You can enable or disable various iDRAC parameters by using the iDRAC settings.

 **NOTE:** Accessing some of the features on the iDRAC settings needs the iDRAC Enterprise License upgrade.

For more information about using iDRAC, see *Dell Integrated Dell Remote Access Controller User's Guide* at [iDRAC Manuals](#).

## Device Settings

**Device Settings** enables you to configure device parameters such as storage controllers or network cards.

## Boot Manager

The **Boot Manager** option enables you to select boot options and diagnostic utilities.

To enter **Boot Manager**, power on the system and press F11.

**Table 49. Boot Manager details**

Option	Description
<b>Continue Normal Boot</b>	The system attempts to boot to devices starting with the first item in the boot order. If the boot attempt fails, the system continues with the next item in the boot order until the boot is successful or no more boot options are found.
<b>One-shot UEFI Boot Menu</b>	Enables you to access the boot menu, where you can select a one-time boot device to boot from.
<b>Launch System Setup</b>	Enables you to access System Setup.
<b>System Utilities</b>	Enables you to launch the System Utilities menu such as Launch Diagnostics, BIOS update File Explorer, Reboot System.

## PXE boot

You can use the Preboot Execution Environment (PXE) option to boot and configure the networked systems remotely.

To access the **PXE boot** option, boot the system and then press F12 during POST instead of using standard Boot Sequence from BIOS Setup. It does not pull any menu or allows managing of network devices.

# Minimum to POST and system management configuration validation

This section describes the minimum to POST system requirement and system management configuration validation of the Dell system.

## Topics:

- [Minimum configuration to POST](#)

## Minimum configuration to POST

The components that are listed below are the minimum configuration to POST:

- One processor in processor socket 0
- One memory module (DIMMs) in slot A1. (Only 32 GB allowed for 1DIMM per processor with limited features)
- One power supply unit
- Intrusion switch + dongle cable
- Host Processor Module (HPM)\* + Data Center Secured Control Module (DC-SCM)

 **NOTE:** HPM is also known as System board.

## Configuration validation

The new generation of Dell systems have added interconnect flexibility and advanced iDRAC management features to collect precise system configuration information and report configuration errors.

When the system is powered on, information about installed cables, risers, backplanes, power supplies, floating card (fPERC, adapter PERC, BOSS), and processor is obtained from the CPLD and backplane memory maps are analyzed. This information forms a unique configuration, which is compared with one of the qualified configurations that are stored in a table maintained by iDRAC.

One or more sensors are assigned to each of the configuration elements. During POST, any configuration validation error is logged in the System Event Log (SEL) log. The reported events are categorized in the configuration validation error table.

**Table 50. Configuration validation error**



Error	Description	Possible cause and recommendations	Example
Config Error	A configuration element within the closest match contains something that is unexpected and does not match any Dell qualified configuration.	Wrong configuration	Config Error: Backplane cable CTRS_SRC_SA1 and BP-DST_SA1
		The element reported in HWC8010 errors are assembled incorrectly. Verify element (cable, risers, etc) placement in the system.	Config Error : SL Cable PLANAR_SL2 and CTRL_DST_PA1
Config Missing	iDRAC found a configuration element missing within the closest match detected.	Missing or damaged cable, device, or part	Config Missing: Float card front PERC/HBA, adapter PERC/HBA
		Missing element or cable is reported in HWC8010 error logs. Install the missing element (cable, risers, etc).	Config Missing : SL cable PLANAR_SL8 and CTRL_DST_PA1
Comm Error	A configuration element is not responding to iDRAC using the management interface while running an inventory check.	System management sideband communication	Comm Error: Backplane 2
		Unplug AC Power, reseal the element and replace the element if the problem persists.	

# Disassembly and reassembly

## Topics:

- Safety instructions
- Before working inside your system
- After working inside your system
- Recommended tools
- Optional front bezel
- System cover
- Cooling fans
- Air shroud
- Drive backplane cover
- PERC modules
- Drives
- Drive backplane
- Side wall brackets
- Middle bracket
- Cable routing
- System memory
- Processor and heat sink
- Removing the Direct Liquid Cooling module
- Installing the Direct Liquid Cooling module
- Expansion cards and expansion card risers
- M.2 SSD module
- Optional BOSS-N1 DC-MHS module
- Optional M.2 Interposer board
- Optional OCP NIC card
- Datacenter-Secure Control Module (DC-SCM)
- Attic board
- Optional internal USB port
- System battery
- Intrusion switch
- Power supply unit
- DB9+RJ45 module
- Trusted Platform Module
- HPM board
- Control panel

## Safety instructions

-  **CAUTION:** Whenever you need to lift the system, get others to assist you. To avoid injury, do not attempt to lift the system by yourself.
-  **CAUTION:** Ensure that two or more people lift the system horizontally from the box and place it on a flat surface, rack lift, or into the rails.
-  **WARNING:** Opening or removing the system cover while the system is powered on may expose you to a risk of electric shock.

**⚠ WARNING:** Do not operate the system without the cover for a duration exceeding five minutes. Operating the system without the system cover can result in component damage.

**⚠ CAUTION:** Many repairs may only be done by a certified service technician. You should only perform troubleshooting and simple repairs as authorized in your product documentation, or as directed by the online or telephone service and support team. Damage due to servicing that is not authorized by Dell is not covered by your warranty. Read and follow the safety instructions that are shipped with your product.

**ⓘ NOTE:** It is recommended that you always use an antistatic mat and antistatic strap while working on components inside the system.

**⚠ CAUTION:** To ensure proper operation and cooling, all system bays and fans must always be populated with a component or a blank.

**ⓘ NOTE:** Only use certified Optical Fiber Transceiver Class I Laser Products.

**⚠ CAUTION:** Do not install GPUs, network cards, or other PCIe devices on your system that are not validated and tested by Dell. Damage caused by unauthorized and invalidated hardware installation will null and void the system warranty.

## Before working inside your system

### Prerequisites

Follow the safety guidelines listed in the [Safety instructions](#).

### Steps

1. Power off the system and all attached peripherals.
2. Disconnect the system from the electrical outlet and disconnect the peripherals.
3. If applicable, remove the system from the rack.

For more information, see the *Rail Installation Guide* relevant to your rail solutions at [PowerEdge manuals](#).

4. Remove the system cover.

**ⓘ NOTE:** While removing the hot-swappable components from the front or rear of the system, do not remove the system cover.

## After working inside your system

### Prerequisites

Follow the safety guidelines listed in [Safety instructions](#).

### Steps

1. Replace the system covers.
2. If applicable, install the system into the rack.  
For more information, see the *Rail Installation Guide* relevant to your system at [PowerEdge manuals](#).
3. Reconnect the peripherals and connect the to the electrical outlet, and then power on the system.

## Recommended tools

You may need some or all of the following tools to perform the removal and installation procedures:

- Phillips 1 screwdriver
- Phillips 2 screwdriver
- Torx T30 screwdriver

- 5 mm hex nut screwdriver
- Plastic scribe
- 1/4-inch flat blade screwdriver
- Wrist grounding strap connected to the ground
- ESD mat
- Needle-nose pliers

## Optional front bezel

### Removing the front bezel

#### Prerequisites

1. Follow the safety guidelines listed in the [Safety instructions](#).
2. Keep the bezel key handy.

**NOTE:** The bezel key is part of the bezel package.

#### Steps

1. Unlock the bezel.
2. Press the release button, and disengage the left end of the bezel.
3. Unhook the right end, and remove the bezel.

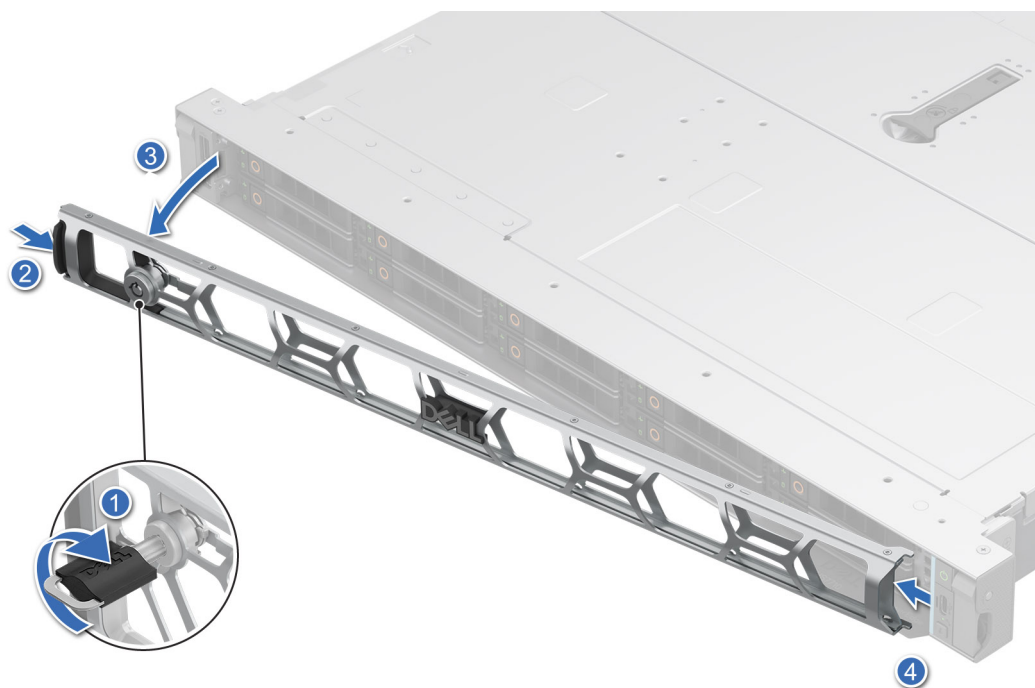

Figure 36. Removing the front bezel

#### Next steps

Replace front bezel.

# Installing the front bezel

## Prerequisites

1. Follow the safety guidelines listed in the [Safety instructions](#).
2. Locate and remove the bezel key.

**NOTE:** The bezel key is part of the bezel package.

## Steps

1. Align and insert the tabs on the bezel into the slots on the system.
2. Press the bezel until the release button clicks in place.
3. Lock the bezel.



Figure 37. Installing the front bezel

# System cover

## Removing the system cover

### Prerequisites

1. Follow the safety guidelines listed in the [Safety instructions](#).
2. Power off the system, and any attached peripherals.
3. Disconnect the system from the electrical outlet and peripherals.

### Steps

1. Using a 1/4-inch flat head or a Phillips 2 screwdriver, rotate the lock counterclockwise to the unlock position.
2. Lift the release latch until the system cover slides back.
3. Lift the cover from the system.

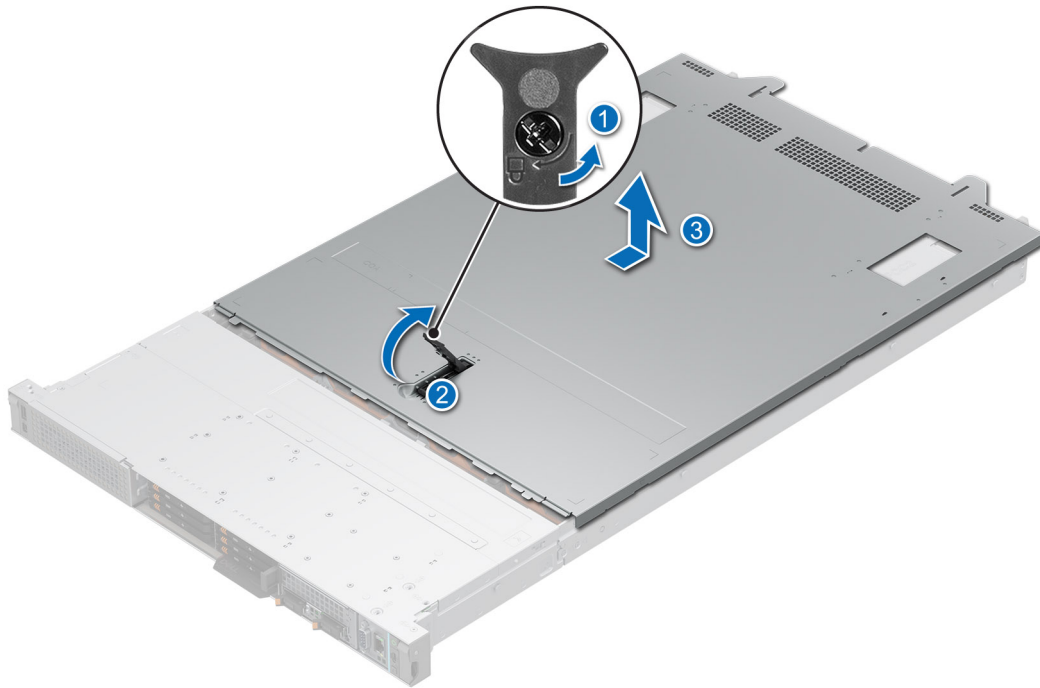

**Figure 38. Removing the system cover**

#### **Next steps**

Replace the system cover.

## **Installing the system cover**

#### **Prerequisites**

1. Follow the safety guidelines listed in the [Safety instructions](#).
2. Follow the procedure listed in [Before working inside your system](#).
3. Ensure that all internal cables are connected and routed properly, and no tools or extra parts are left inside the system.

#### **Steps**

1. Align the tabs on the system cover with the guide slots on the system and slide the system cover.
2. Close the system cover release latch.
3. Using a 1/4-inch flat head or Phillips 2 screwdriver, rotate the lock clockwise to the lock position.

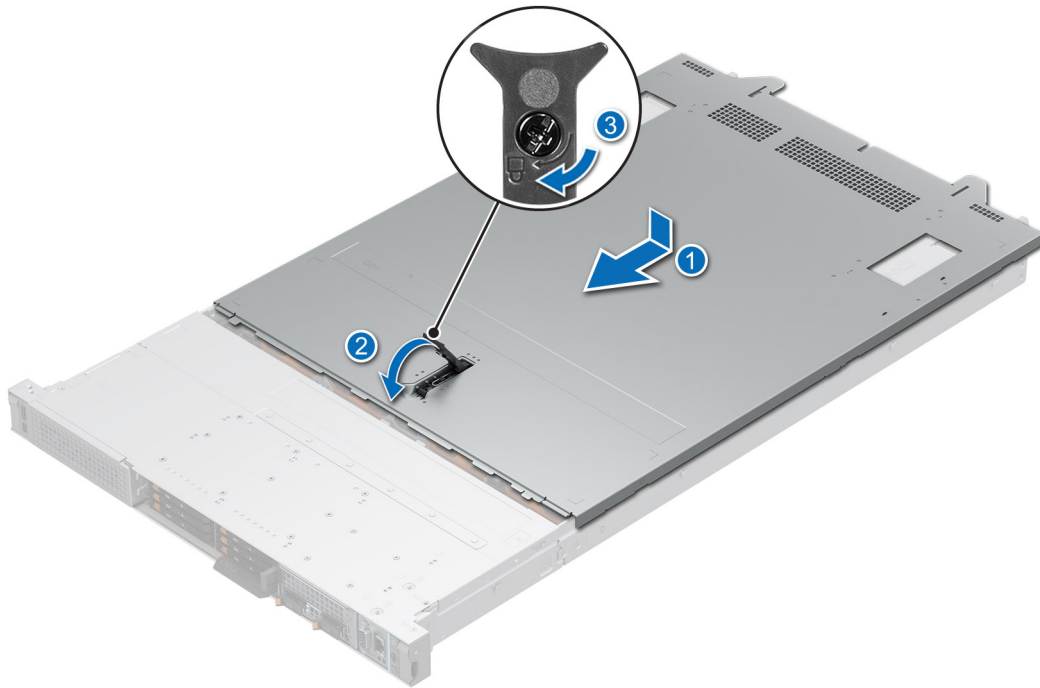

**Figure 39. Installing the system cover**

#### **Next steps**

Follow the procedure listed in [After working inside your system](#).

## **Cooling fans**

### **Removing a cooling fan**

#### **Prerequisites**

1. Follow the safety guidelines listed in the [Safety instructions](#).
2. Follow the procedure listed in [Before working inside your system](#).

#### **Steps**

Holding the orange and black edges on the fan module, lift the cooling fan module to disconnect from the connector on the fan board.

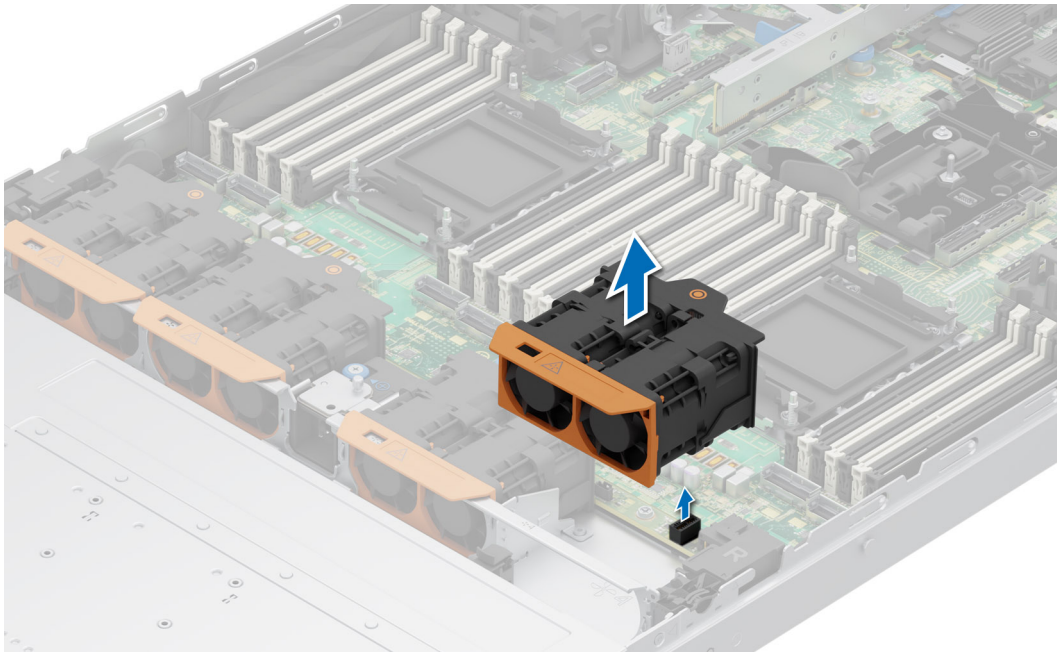

**Figure 40. Removing a cooling fan**

#### **Next steps**

Replace a cooling fan.

## **Installing a cooling fan**

#### **Prerequisites**

1. Follow the safety guidelines listed in the [Safety instructions](#).
2. Follow the procedure listed in [Before working inside your system](#).

#### **Steps**

Align and lower the cooling fan onto the connector on the fan board, then press the orange touch point on the cooling fan module until it is firmly connected.

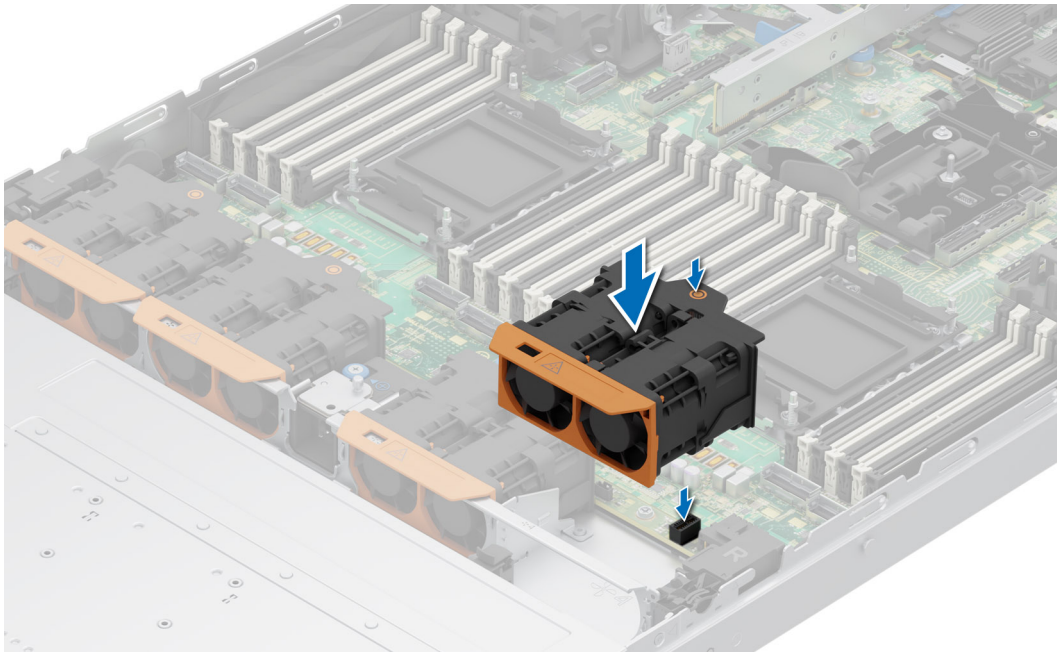

**Figure 41. Installing a cooling fan**

**Next steps**

Follow the procedure listed in [After working inside your system.](#)

# Air shroud

## Removing the air shroud

### Prerequisites

**CAUTION:** Never operate your system with the air shroud removed. The system may get overheated quickly, resulting in shutdown of the system and loss of data.

1. Follow the safety guidelines listed in the [Safety instructions](#).
2. Follow the procedure listed in [Before working inside your system](#).
3. Remove the cables from the air shroud notch and place them on other shroud.

### Steps

1. Press the latch on the air shroud at both the ends.
2. Hold the air shroud at both ends and lift the air shroud out of the system.

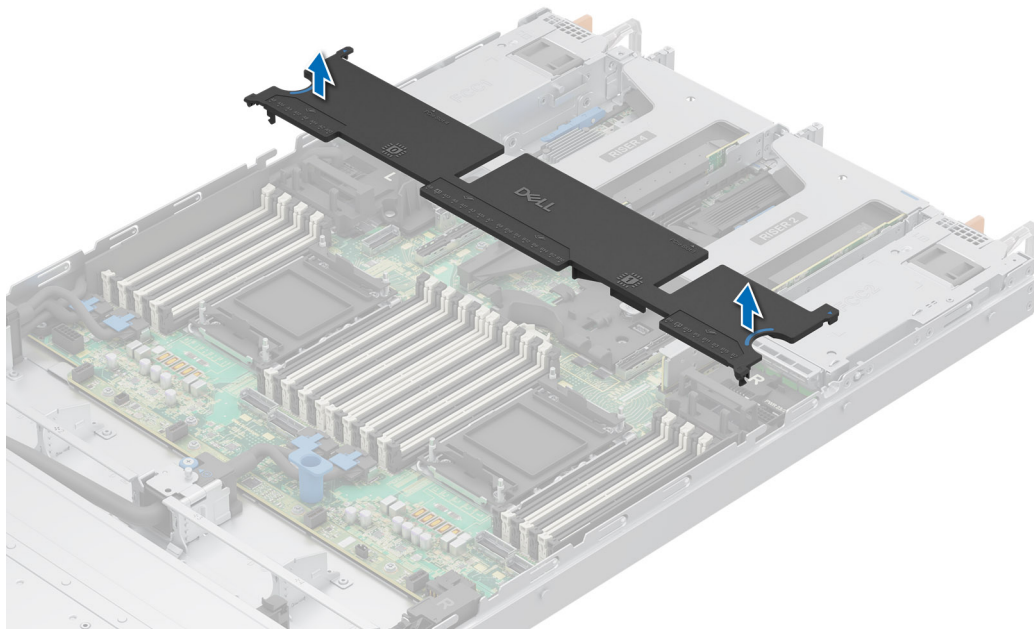

Figure 42. Removing the air shroud

### Next steps

[Replace the air shroud.](#)

## Installing the air shroud

### Prerequisites

1. Follow the safety guidelines listed in the [Safety instructions](#).
2. Follow the procedure listed in [Before working inside your system](#).
3. Remove the cables from the air shroud notch and place them on the other shroud.

### Steps

1. Align the slot on the air shroud with the standoff on the chassis.

2. Lower the air shroud into the system until it is firmly seated.

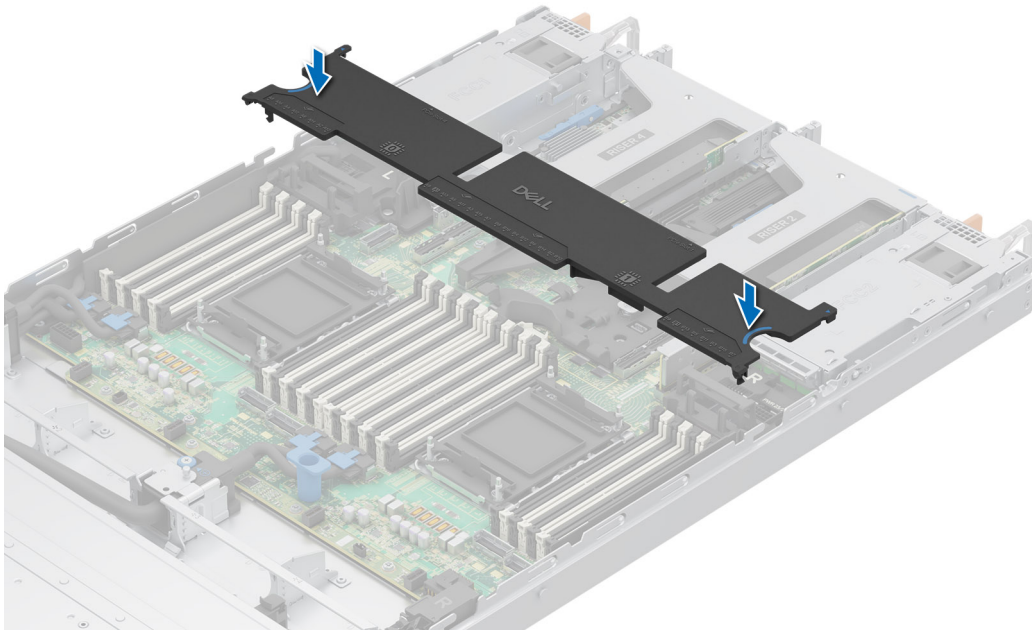

**Figure 43. Installing the air shroud**

#### **Next steps**

1. Route the cables along the air shroud notch.
2. Follow the procedure listed in [After working inside your system](#).

## **Drive backplane cover**

### **Removing the drive backplane cover**

#### **Prerequisites**

1. Follow the safety guidelines listed in the [Safety instructions](#).
2. Follow the procedure listed in [Before working inside your system](#).

#### **Steps**

1. Slide the drive backplane cover in the direction of the arrows marked on the drive backplane cover.
2. Lift the drive backplane cover from the system.

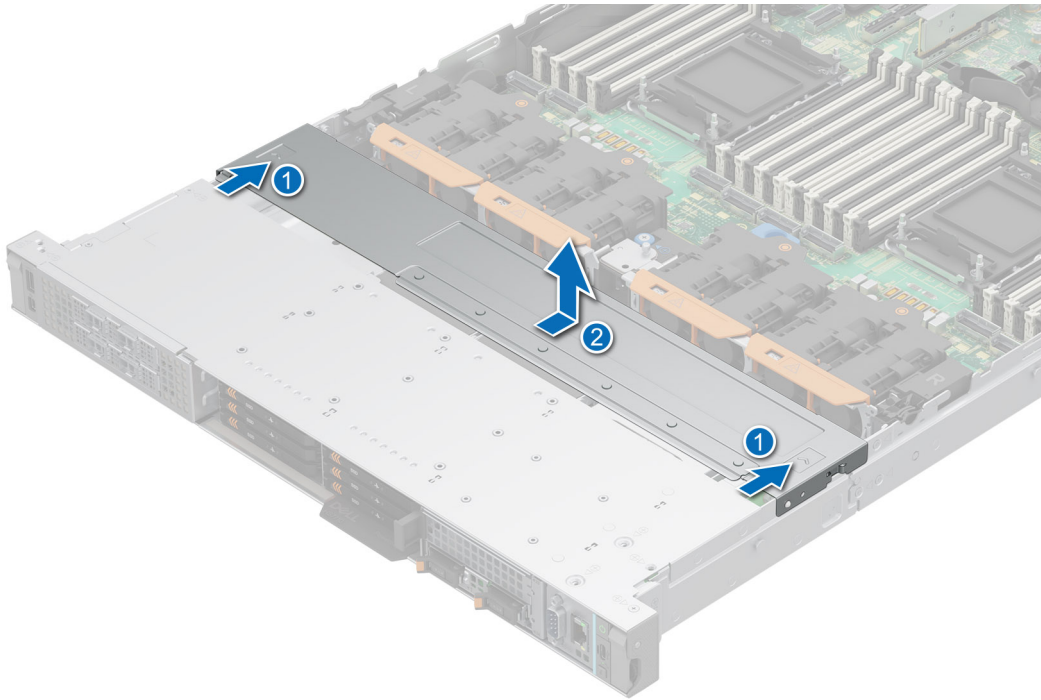

**Figure 44. Removing the drive backplane cover**

#### **Next steps**

1. [Replace the drive backplane cover.](#)

## **Installing the drive backplane cover**

#### **Prerequisites**

1. Follow the safety guidelines listed in the [Safety instructions](#).
2. Follow the procedure listed in [Before working inside your system](#).

#### **Steps**

1. Align the drive backplane cover with the guide slots on the system.
2. Slide the drive backplane cover to the front of the system until the drive backplane cover fits into place.

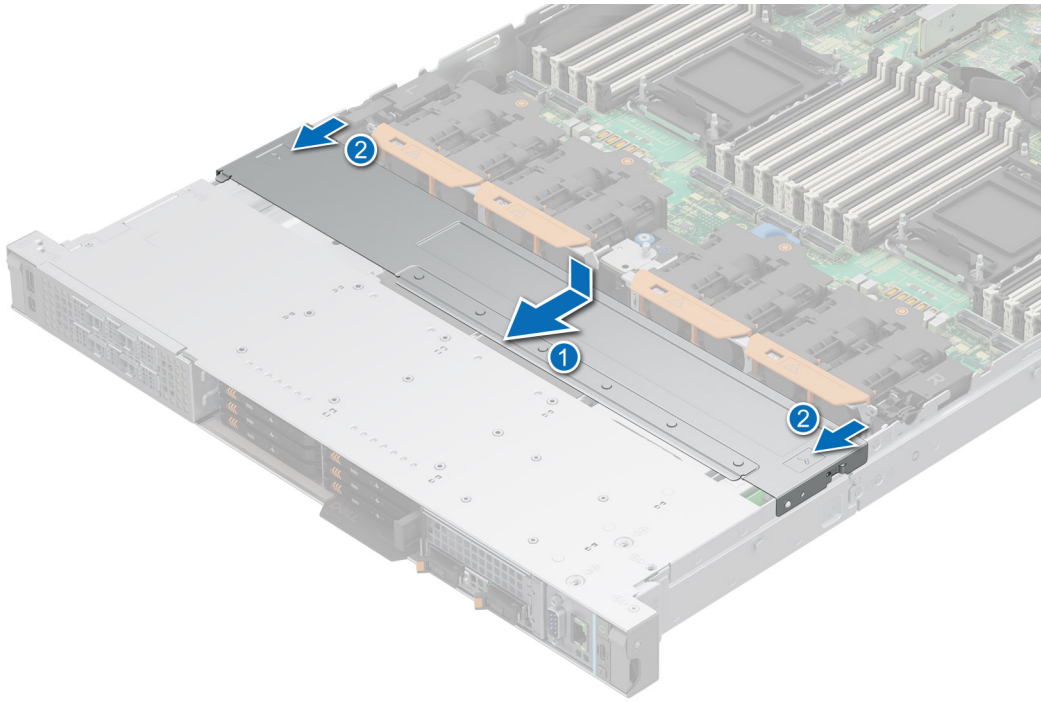

**Figure 45. Installing the drive backplane cover**

#### Next steps

1. Follow the procedure listed in [After working inside your system](#).

## PERC modules

### Removing the rear mounting front PERC module

#### Prerequisites

1. Follow the safety guidelines listed in the [Safety instructions](#).
2. Follow the procedure listed in the [Before working inside your system](#).
3. [Remove the cooling fan](#).
4. [Remove the drive backplane cover](#).
5. If required, [remove the air shroud](#).
6. Disconnect all the cables from the PERC, observe the cable routing.

#### Steps

1. Pull the plunger.
2. Slide and lift the front PERC module out of the system.

**NOTE:** The numbers on the image do not depict the exact steps. The numbers are for representation of sequence.

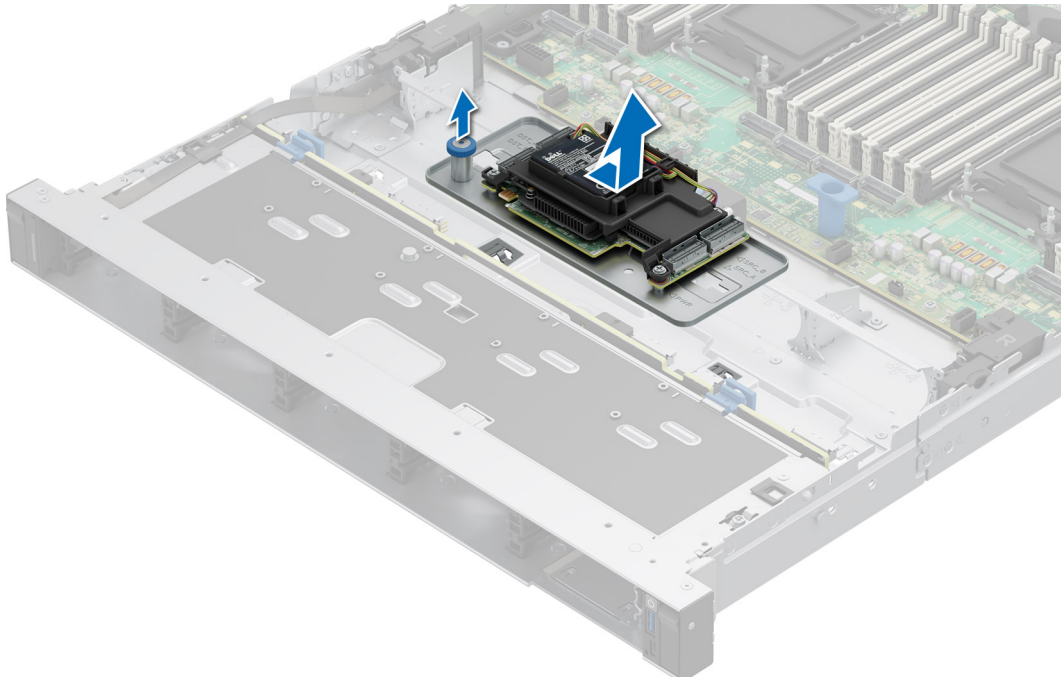

**Figure 46. Removing the front mounting front PERC module**

3. Remove the front PERC battery cables from the cable clip.

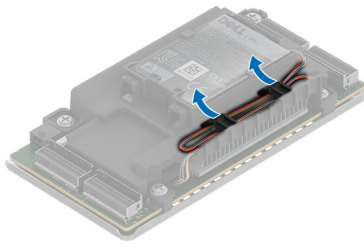

**Figure 47. Removing the front PERC battery cables from the cable clip**

4. Remove the battery with its holder out of the PERC shroud on the tray. Using a Phillips 2 screwdriver, loosen the screws to remove the shroud from the front PERC, then remove the front PERC from the tray.

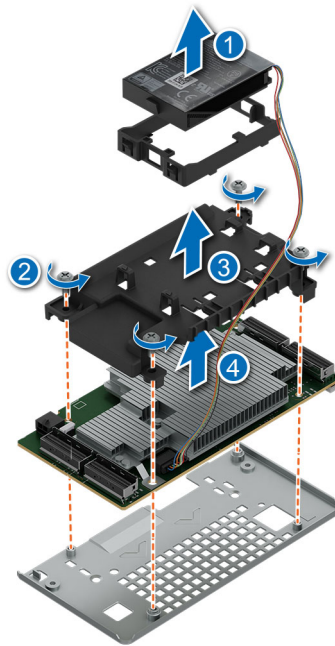

**Figure 48. Removing the rear mounting front PERC module from the PERC tray**

#### **Next steps**

Replace the front mounting front PERC module.

## **Installing the rear mounting front PERC module**

#### **Prerequisites**

1. Follow the safety guidelines listed in the [Safety instructions](#).
2. Follow the procedure listed in [Before working inside your system](#).
3. [Remove the cooling fan](#).
4. [Remove the drive backplane cover](#).
5. If required, [remove the air shroud](#).
6. Route the cable properly to prevent the cable from being pinched or crimped.

#### **Steps**

1. Align the front PERC and the shroud with the screw-guide pins on the PERC tray. Using a Phillips 2 screwdriver, tighten the screws to secure them in place. Insert the front PERC battery into the holder.

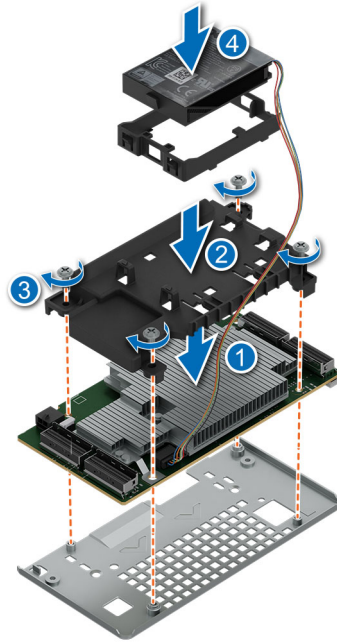

**Figure 49. Installing the rear mounting front PERC module on the PERC tray**

2. Route the front PERC battery cables through the cable clip.

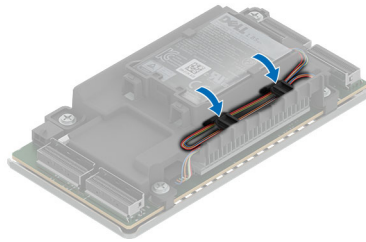

**Figure 50. Installing the front PERC battery cables**

3. Connect the PERC cable to the front PERC module.
4. Align the front PERC module until the tray touches the slot in the system.
5. Push the front PERC to the correct location, the plunger will fix automatically.

**NOTE:** The numbers on the image do not depict the exact steps. The numbers are for representation of sequence.

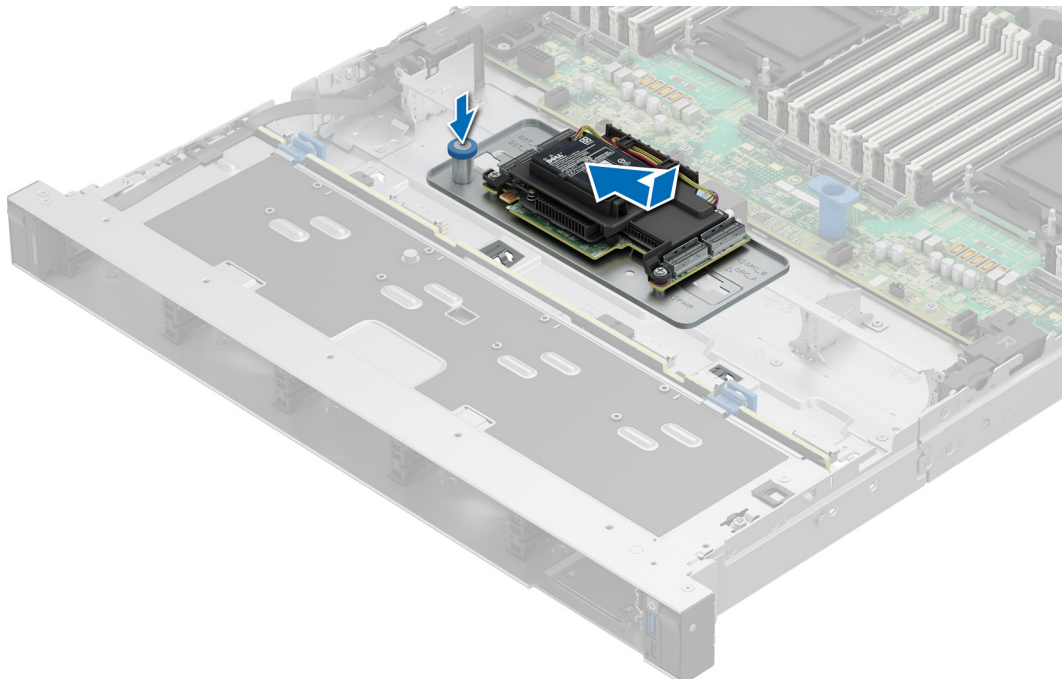

**Figure 51. Installing the front mounting front PERC module**

#### Next steps

1. Reconnect all the required cables.
2. [Install the drive backplane cover.](#)
3. [Install the cooling fans.](#)
4. If removed, [install the air shroud.](#)
5. Follow the procedure listed in [After working inside your system.](#)

## Removing the front H975i PERC module

#### Prerequisites

1. Follow the safety guidelines listed in the [Safety instructions.](#)
2. Follow the procedure listed in the [Before working inside your system.](#)
3. [Remove the drive backplane cover.](#)
4. Disconnect the cables from PERC, observe the cable routing.

#### Steps

1. Disconnect the power cable from the H975i module. Using a Phillips 2 screwdriver, loosen the screw and slide the battery cage out from the system.

**i** **NOTE:** The numbers on the image do not depict the exact steps. The numbers are for representation of sequence.

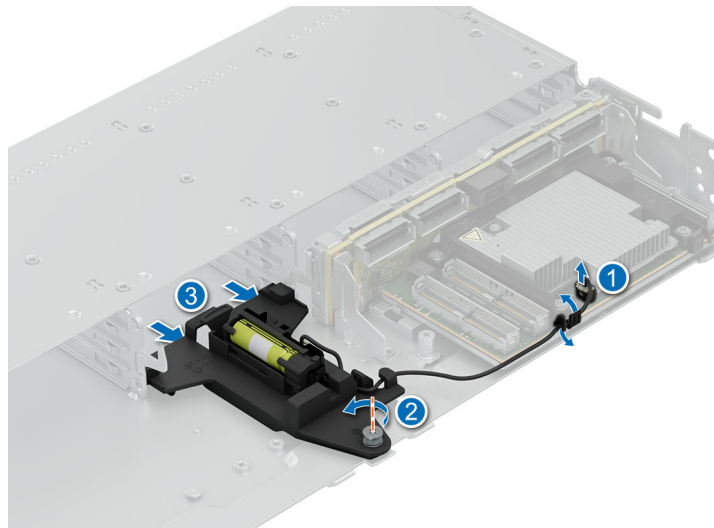

**Figure 52. Removing the battery cage**

2. Remove the PERC backplane from the backplane bay.
3. Using a Phillips 2 screwdriver, loosen the screws and slide out the H975i module from the backplane bay.

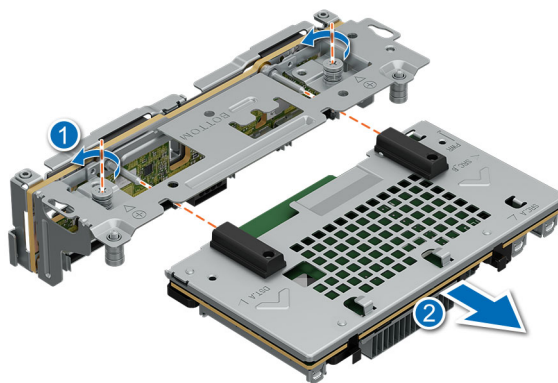

**Figure 53. Removing the H975i module from the backplane bay**

4. Using a Phillips 2 screwdriver, loosen the screws and remove the H975i from the bracket, and the shroud from the H975i.

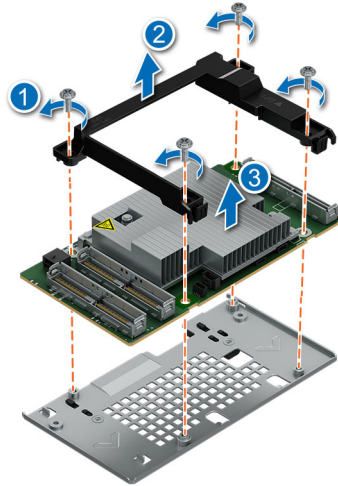

**Figure 54. Removing the H975i and shroud**

5. Slide the battery holder out from the cage and remove it.

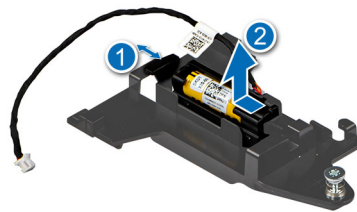

**Figure 55. Removing the battery holder**

#### **Next steps**

1. [Replace the front PERC module.](#)

## **Installing the front H975i PERC module**

#### **Prerequisites**

1. Follow the safety guidelines listed in the [Safety instructions](#).
2. Follow the procedure listed in the [Before working inside your system](#).
3. [Remove the drive backplane cover.](#)

#### **Steps**

1. Insert the battery holder into the cage and slide it forward to secure it in place.

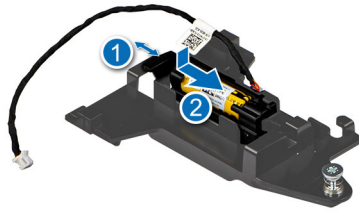

**Figure 56. Installing the battery holder to the cage**

2. Align the H975i and the shroud with the screw-guide pins on the bracket. Using a Phillips 2 screwdriver, tighten the screws to secure them in place.

**i** **NOTE:** The numbers on the image do not depict the exact steps. The numbers are for representation of sequence.

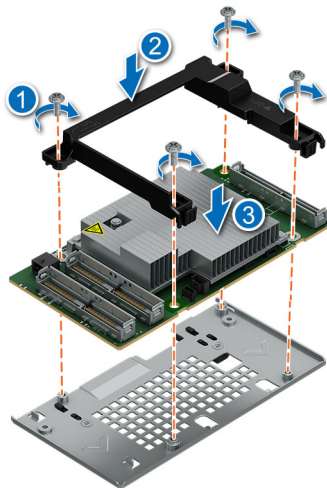

**Figure 57. Installing the H975i, bracket, and shroud**

3. Align the H975i module with the guide pins on the PERC backplane bay and slide it in. Using the Phillips 2 screwdriver, secure the module in place.

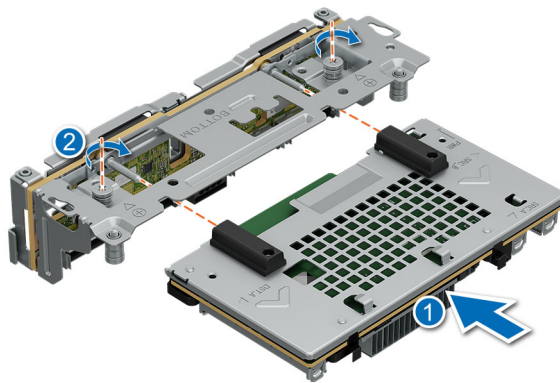

**Figure 58. Installing the H975i to the backplane bay**

4. Insert the battery cage into the drive bay. Using a Phillips 2 screwdriver, tighten the screw to secure it in place. [Install the PERC backplane](#) to the drive bay. Connect the power cable from the battery to the H975i module.

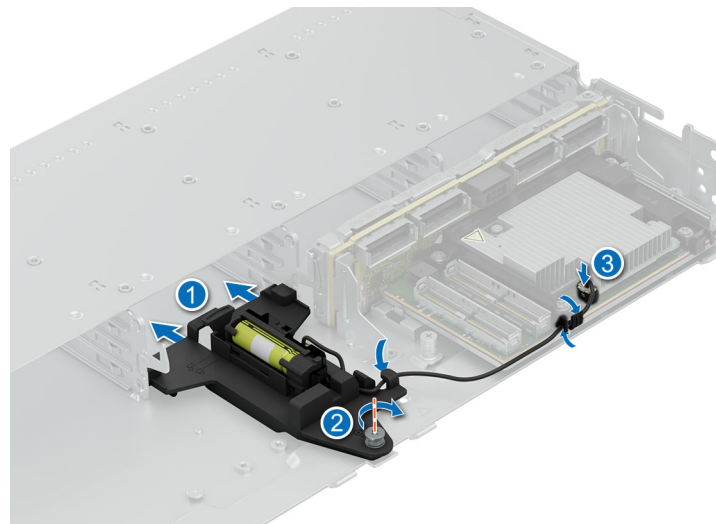

**Figure 59. Installing the battery cage to the system**

**NOTE:** See the [cable routing](#) section for more information.

### Next steps

1. Reconnect all the required cables.
2. [Install the drive backplane cover](#).
3. [Install the cooling fans](#).
4. If removed, [install the air shroud](#).
5. Follow the procedure listed in [After working inside your system](#).

# Drives

## Removing a 2.5-inch drive blank

### Steps

Press the release button, and slide the drive blank out of the drive slot.

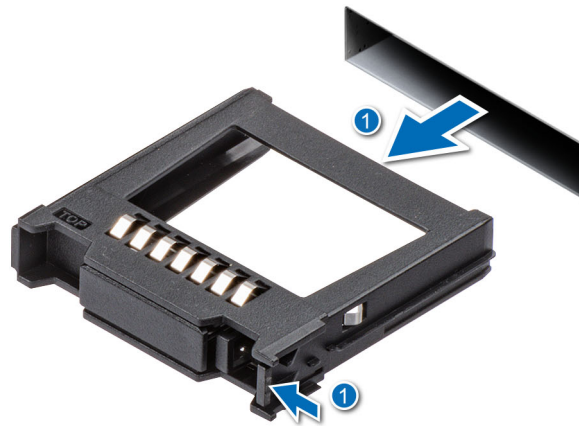

Figure 60. Removing a 2.5-inch drive blank

## Installing a 2.5-inch drive blank

### Steps

Insert the drive blank into the drive slot, and push the blank until the release button clicks into place.

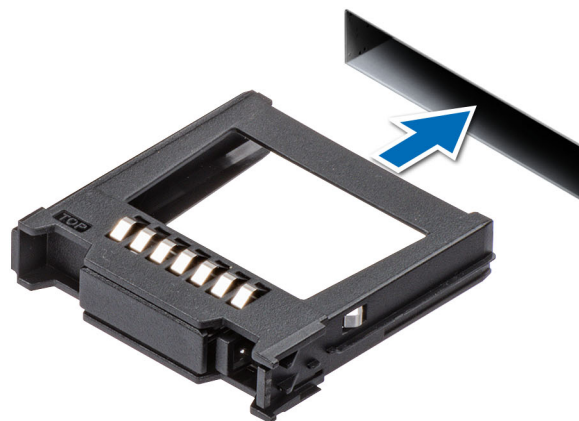



Figure 61. Installing a 2.5-inch drive blank

## Removing a 2.5-inch drive carrier

### Steps

1. Press the release button to open the drive carrier release handle.
2. Holding the handle, slide the drive carrier out of the drive slot.

 **NOTE:** The numbers on the image do not depict the exact steps. The numbers are for representation of sequence.

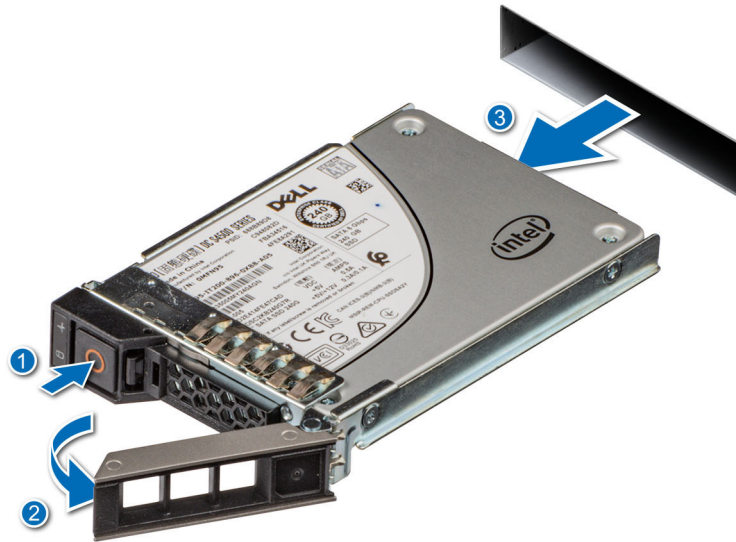

Figure 62. Removing a 2.5-inch drive carrier

## Removing a 2.5-inch drive from the drive carrier

### Steps

1. Using a Phillips #1 screwdriver, remove the screws from the slide rails on the drive carrier.

**NOTE:** If the hard drive or SSD carrier has a Torx screw, use Torx 6 (for 2.5-inch drive) screwdriver to remove the drive.

2. Lift the drive out of the drive carrier.

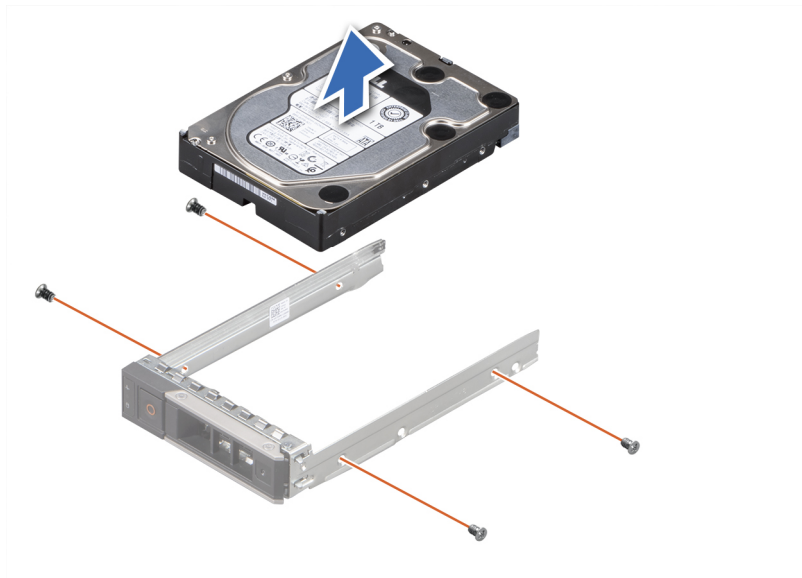



Figure 63. Removing the 2.5-inch drive from the drive carrier

## Installing a 2.5-inch drive into the drive carrier

### Steps

1. Insert the drive into the drive carrier with the connector end of the drive towards the back of the carrier.
2. Align the screw holes on the drive with the screw holes on the drive carrier.
3. Using a Phillips #1 screwdriver, replace the screws to secure the drive to the drive carrier.

**i** **NOTE:** If the hard drive or SSD carrier has a Torx screw, use Torx 6 (for 2.5-inch drive) screwdriver to install the drive. 

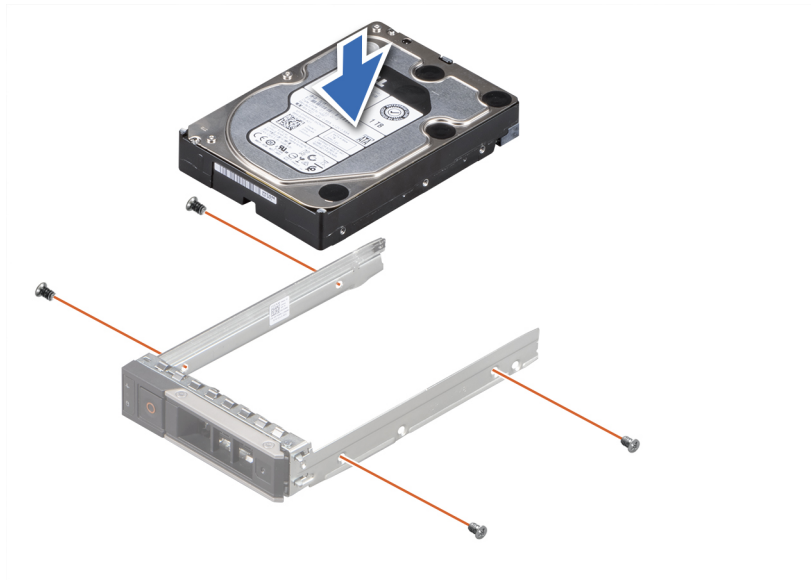

**Figure 64. Installing a drive into the drive carrier**

## Installing a 2.5-inch drive carrier

### Steps

1. Press the release button on the front of the drive carrier to open the release handle.
2. Insert and slide the drive carrier into the drive slot.
3. Close the drive carrier release handle until it clicks in place.

**i** **NOTE:** The numbers on the image do not depict the exact steps. The numbers are for representation of sequence.

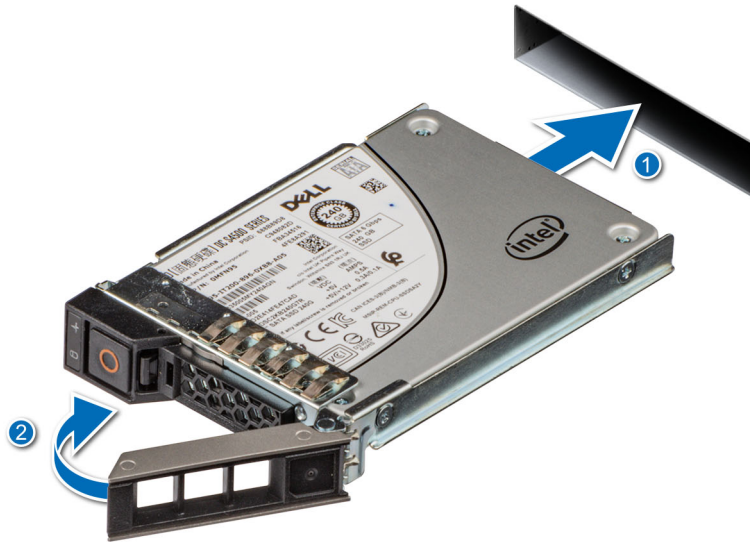

Figure 65. Installing a 2.5-inch drive carrier

## Removing an EDSFF E3.S drive blank

### Prerequisites

1. Follow the safety guidelines listed in the [Safety instructions](#).

**CAUTION:** To maintain proper system cooling, drive blanks must be installed in all empty drive slots.

### Steps

Lift the release button, and slide the drive blank out of the drive slot.



Figure 66. Removing an EDSFF E3.S drive blank

### Next steps

1. [Replace the EDSFF E3.S drive blank.](#)

## Installing an EDSFF E3.S drive blank

### Prerequisites

1. Follow the safety guidelines listed in the [Safety instructions](#).

### Steps

Slide the drive blank into the drive slot until the release button clicks into place.



Figure 67. Installing an EDSFF E3.S drive blank

## Removing an EDSFF E3.S drive carrier

### Prerequisites

1. Follow the safety guidelines listed in [Safety instructions](#).
2. Using the management software, prepare the drive for removal. If the drive is online, the green activity or fault indicator flashes while the drive is turning off. When the drive indicators are off, the drive is ready for removal. For more information, see the storage controller documentation.

**CAUTION:** Before attempting to remove or install a drive while the system is running, see the documentation for the storage controller card to ensure that the host adapter is configured correctly to support drive removal and insertion.

**CAUTION:** To prevent data loss, ensure that your operating system supports drive installation. See the documentation supplied with your operating system.

### Steps

1. Lift the release button to open the drive carrier release handle.
2. Holding the drive carrier release handle, slide the drive carrier out of the drive slot.

**NOTE:** If you are not replacing the drive immediately, install an EDSFF E3.S drive blank in the empty drive slot to maintain proper system cooling.

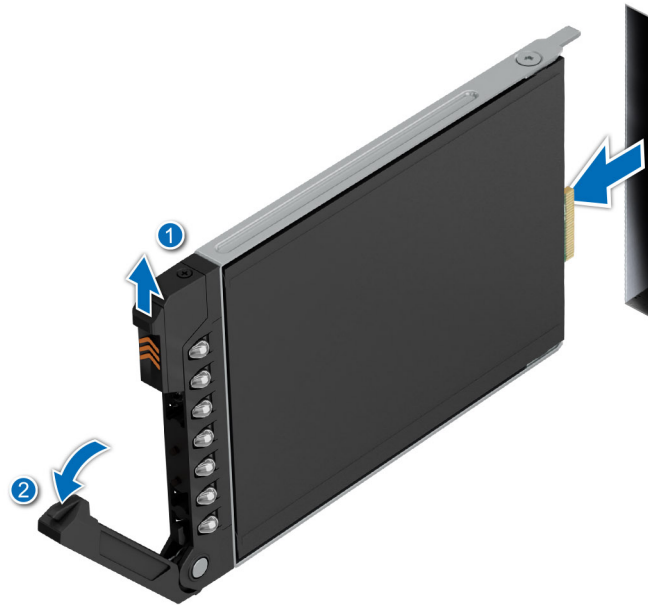

Figure 68. Removing an EDSFF E3.S drive carrier

#### Next steps

Replace the EDSFF E3.S drive or an EDSFF E3.S drive blank.

## Installing an EDSFF E3.S drive carrier

#### Prerequisites

**CAUTION:** Before removing or installing a drive while the system is running, see the [Storage Controller Manuals](#) documentation for the storage controller card to ensure that the host adapter is configured correctly to support drive removal and insertion.

**CAUTION:** Combining SAS and SATA drives in the same RAID volume is not supported.

**CAUTION:** When installing a drive, ensure that the adjacent drives are fully installed. Inserting a drive carrier and attempting to lock its handle next to a partially installed carrier can damage the partially installed carrier's shield spring and make it unusable.

**NOTE:** Ensure that the drive carrier's release handle is in the open position before inserting the carrier into the slot.

**CAUTION:** To prevent data loss, ensure that your operating system supports hot-swap drive installation. See the documentation supplied with your operating system.

**CAUTION:** When a replacement hot swappable drive is installed and the system is powered on, the drive automatically begins to rebuild. Ensure that the replacement drive is blank or contains data that you wish to overwrite. Any data on the replacement drive is immediately lost after the drive is installed.

1. Follow the safety guidelines listed in [Safety instructions](#).
2. Remove the drive carrier or remove the drive blank when you want to assemble the drive into the system.

#### Steps

1. Slide the drive carrier into the drive slot and push until the drive connects with the backplane.
2. Close the drive carrier release handle to lock the drive in place.

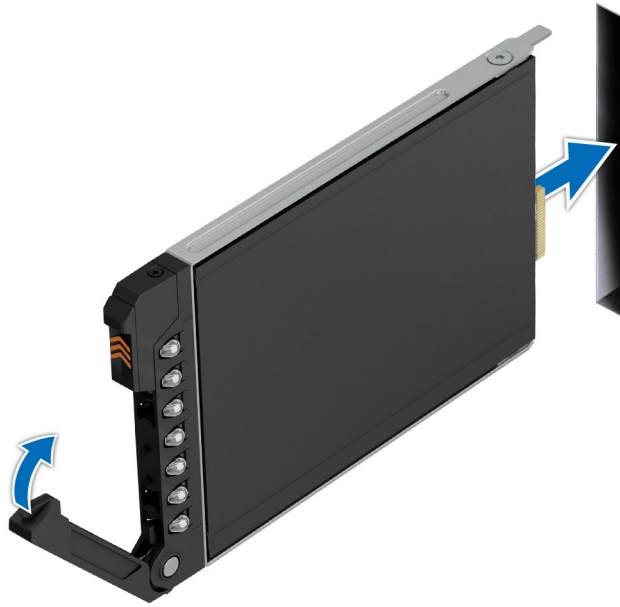

Figure 69. Installing an EDSFF E3.S drive carrier

## Removing an EDSFF E3.S drive from the drive carrier

### Prerequisites

1. Follow the safety guidelines listed in the [Safety instructions](#).
2. [Remove the drive carrier](#).

### Steps

1. Using a Torx 6 screwdriver, remove the screws from the slide rails on the drive carrier.



2. Lift the drive out of the drive carrier.

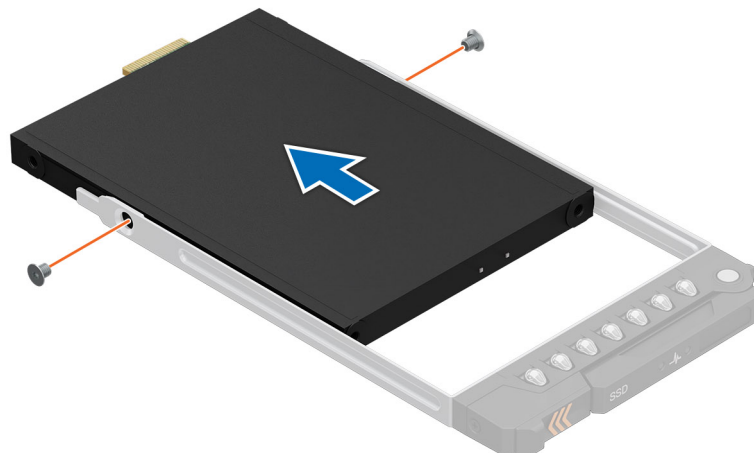

Figure 70. Removing an EDSFF E3.S drive from the drive carrier

### Next steps

Install an EDSFF E3.S drive into the drive carrier.

## Installing an EDSFF E3.S drive into the drive carrier

### Prerequisites

1. Follow the safety guidelines listed in the [Safety instructions](#).
2. [Remove an EDSFF E3.S drive blank](#) or [Remove an EDSFF E3.S drive carrier](#).

### Steps

1. Insert the drive into the drive carrier with the drive connector facing towards the rear of the carrier.
2. Align the screw holes on the drive with the screw holes on the drive carrier.
3. Using a Torx 6 screwdriver, secure the drive to the drive carrier with the screws.

 **NOTE:** When installing a drive into the drive carrier, ensure that the screws are torqued to 4 in-lbs.

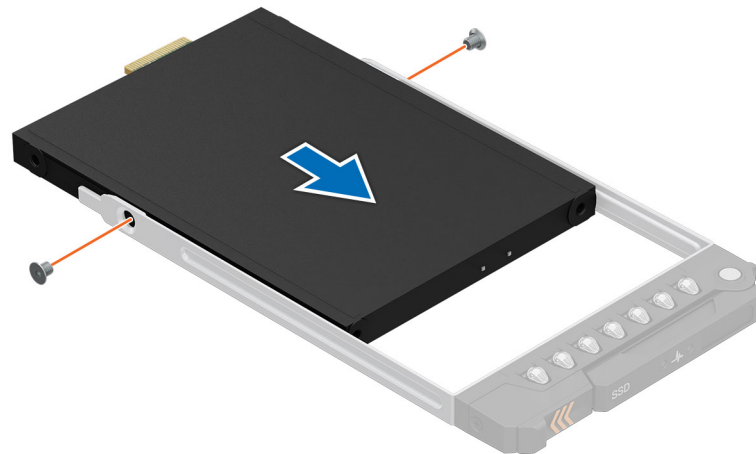

**Figure 71. Installing an EDSFF E3.S drive into the drive carrier**

### Next steps

1. [Install the drive carrier](#).

## Drive backplane

This is a service technician replaceable part only.

## Drive backplane

Depending on your system configuration, the drive backplanes that are supported are listed here:

**Table 51. Supported backplane options**

System	Supported hard drives options
PowerEdge R670	EDSFF E3.S (x8) NVMe backplane
	2.5-inch (x8) SAS/SATA/NVMe backplane

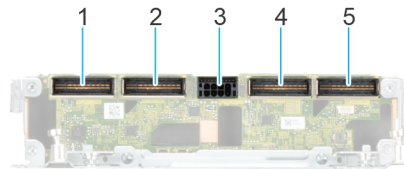

**Figure 72. EDSFF E3.S NVMe drive backplane**

1. BP\_DST\_PA2 (PCIe/NVMe connector, connecting to SL8 on the system board)
2. BP\_DST\_PB2 (PCIe/NVMe connector, connecting to SL7 on the system board)
3. BP\_PWR\_CTRL\_1 (connecting to power cable on the system board)
4. BP\_DST\_PA1 (PCIe/NVMe connector, connecting to SL4 on the system board)
5. BP\_DST\_PB1 (PCIe/NVMe connector, connecting to SL3 on the system board)

## Removing the 2.5-inch drive backplane module

### Steps

1. Pinch and press the release clips on the backplane to disengage it from the system.
2. Lift it towards the rear of the system to remove the backplane.

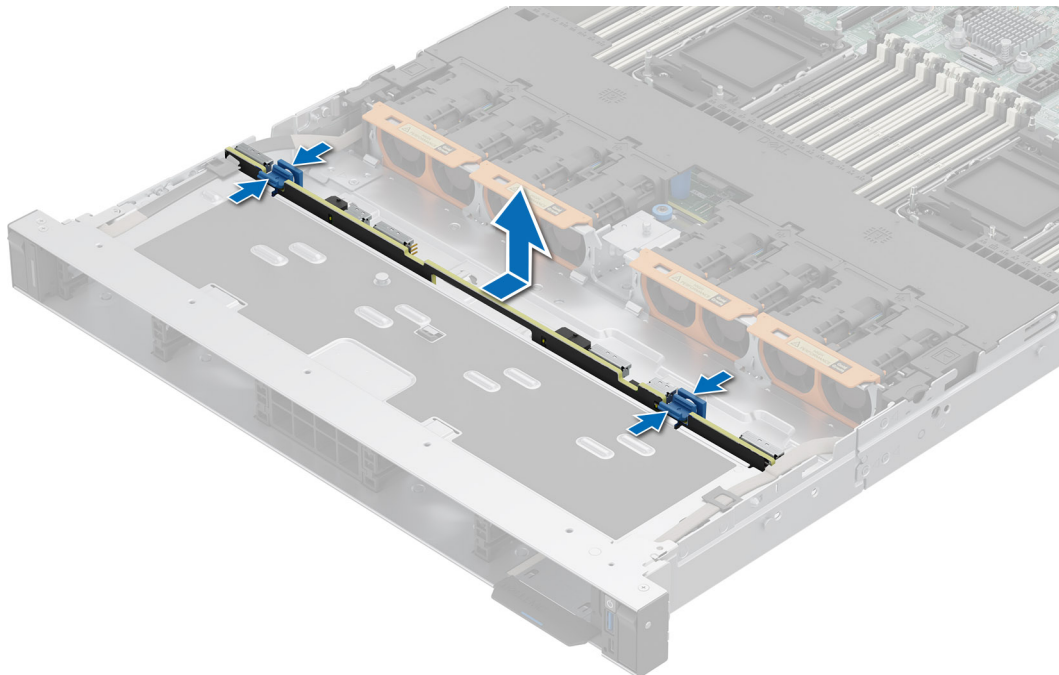

**Figure 73. Removing the 2.5 inch drive backplane module**

## Installing the 2.5-inch drive backplane module

### Steps

1. Align the 2.5-inch drive backplane module with the notches on the system.

2. Pinch and press the release clips on the backplane.
3. Lower the backplane into the system till firmly seated.

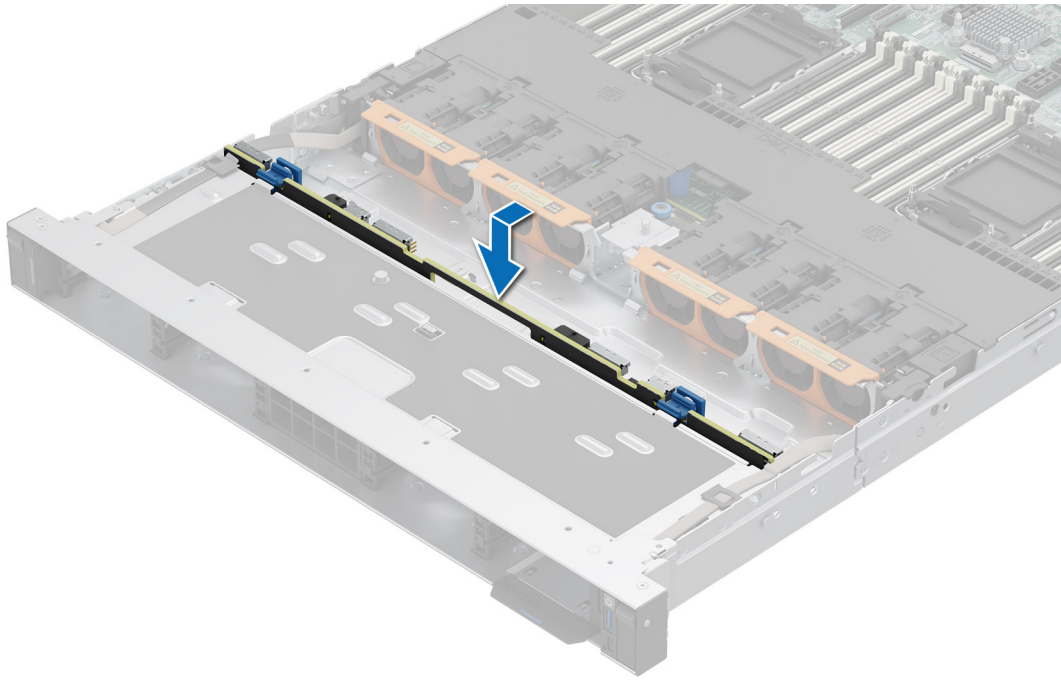

**Figure 74. Installing the 2.5-inch drive backplane module**

## Removing the EDSFF E3.S backplane module

### Prerequisites

1. Follow the safety guidelines listed in the [Safety instructions](#).
2. Follow the procedure listed in the [Before working inside your system](#).
3. [Remove the front bezel](#).
4. [Remove the cooling fans](#).
5. [Remove the drive backplane cover](#).
6. [Remove the EDSFF E3.S drives](#).
7. If required, [remove the L-type processor heatsink module](#) .

**NOTE:** The L-type heatsink prevents the removal of E3.S backplane connectors from the system board.

8. Disconnect the power cable and other required cables, observe the cable routing.

**NOTE:** See [cable routing](#) section.

### Steps

1. Using a Phillips 2 screwdriver, loosen the captive screws on the EDSFF E3.S backplane module.
2. Slide the EDSFF E3.S backplane module towards the front of the server and remove it from the system.

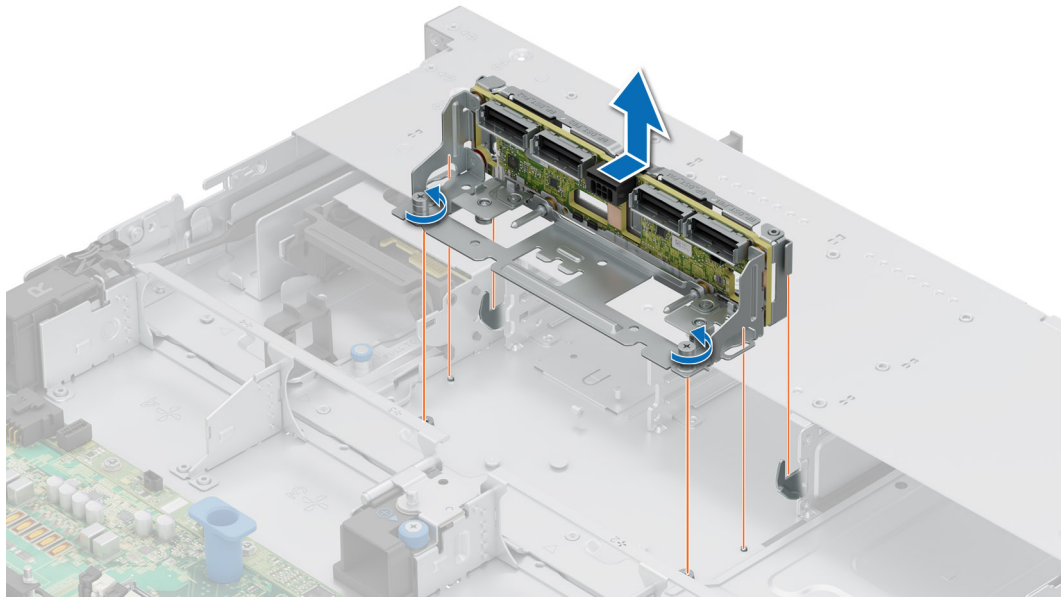

**Figure 75. Removing the EDSFF E3.S backplane module**

#### Next steps

1. [Replace the EDSFF E3.S backplane module.](#)

## Installing the EDSFF E3.S backplane module

#### Prerequisites

1. Follow the safety guidelines listed in the [Safety instructions](#).
2. Follow the procedure listed in the [Before working inside your system](#).
3. [Remove the front bezel.](#)
4. [Remove the cooling fans.](#)
5. [Remove the drive backplane cover.](#)
6. [Remove the EDSFF E3.S drives.](#)
7. If required, [remove the L-type processor heatsink module](#) .

**NOTE:** The L-type heatsink prevents the removal of E3.S backplane connectors from the system board.

8. Disconnect the power cables and other required cables, observe the cable routing.

**NOTE:** See [cable routing](#) section.

#### Steps

1. Align the EDSFF E3.S backplane module with the guide pin on the backplane bracket and position it from the top down, ensuring proper alignment.

**NOTE:** Locate and place the EDSFF E3.S backplane module on the unlocked position line.

2. Push the module towards the rear of the server until it is securely in place.
3. Using a Phillips 2 screwdriver, tighten the captive screws to secure the module.

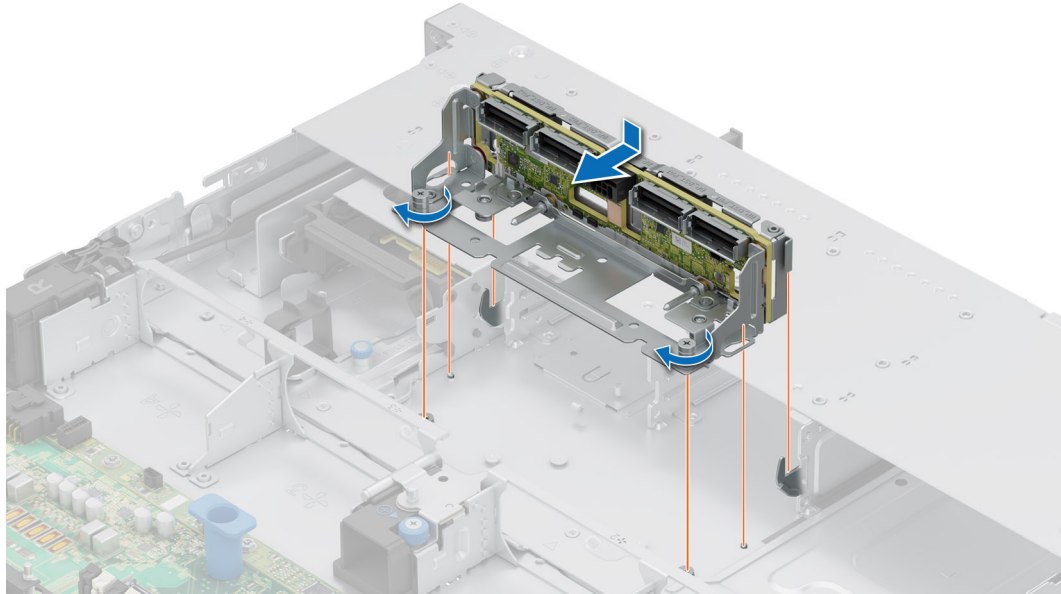

**Figure 76. Installing the EDSFF E3.S backplane module**

### Next steps

1. Connect all the cables, and ensure that all the cables are routed through the respective cable clip.

**i** **NOTE:** See [cable routing](#) section.

2. If removed, [install the L-type processor heatsink module](#) .

**i** **NOTE:** The L-type heatsink prevents the installation of E3.S backplane connectors from the system board.

3. [Install the EDSFF E3.S drives](#) .
4. [Install the drive backplane cover](#).
5. [Install the cooling fans](#).
6. [Install the front bezel](#).
7. Follow the procedure listed in [After working inside your system](#).

## Removing the PERC backplane

### Prerequisites

1. Follow the safety guidelines listed in the [Safety instructions](#).
2. Follow the procedure listed in the [Before working inside your system](#).
3. [Remove the front bezel](#).
4. [Remove the cooling fans](#).
5. [Remove the drive backplane cover](#).
6. [Remove the EDSFF E3.S drives](#).
7. If required, [remove the L-type processor heatsink module](#) .

**i** **NOTE:** The L-type heatsink prevents the removal of E3.S backplane connectors from the system board.

8. Disconnect the power cable and other required cables, observe the cable routing.

**i** **NOTE:** See [cable routing](#) section.

## Steps

Loosen the screws and slide the backplane forward away from the hooks and guide pins and remove it from the system.

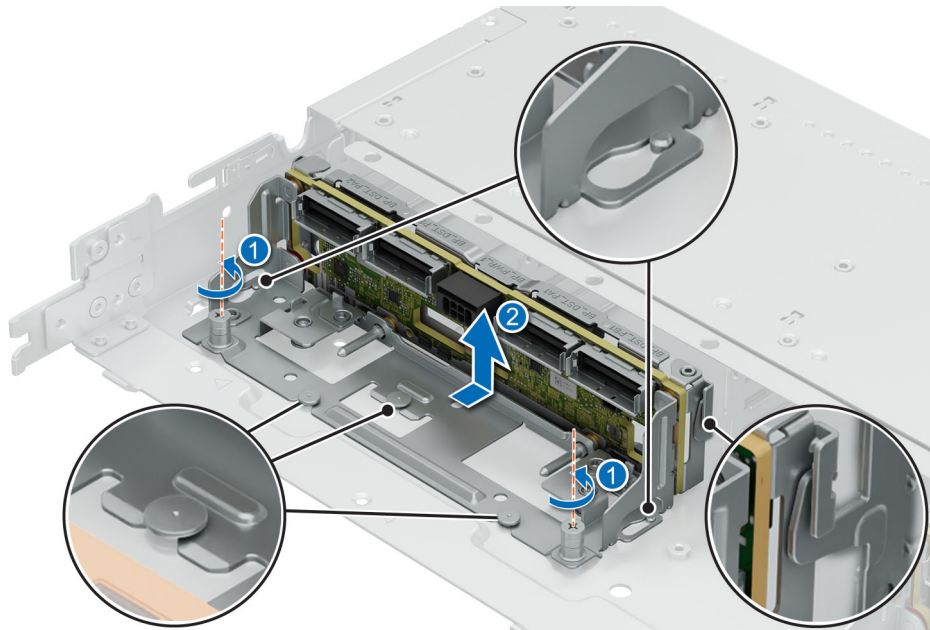

Figure 77. Removing the PERC backplane

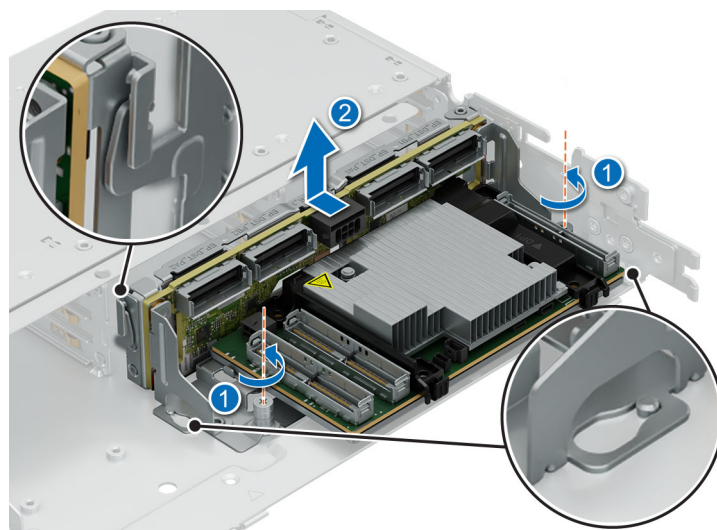

Figure 78. Removing the PERC with H975i module

## Next steps

1. [Replace the drive backplane.](#)

## Installing the PERC backplane

### Prerequisites

1. Follow the safety guidelines listed in the [Safety instructions](#).
2. Follow the procedure listed in the [Before working inside your system](#).
3. [Remove the front bezel.](#)
4. [Remove the cooling fans.](#)

5. Remove the drive backplane cover.
6. Remove the EDSFF E3.S drives.
7. If required, remove the L-type processor heatsink module .

**NOTE:** The L-type heatsink prevents the removal of E3.S backplane connectors from the system board.

8. Disconnect the power cables and other required cables, observe the cable routing.

**NOTE:** See [cable routing](#) section.

### Steps

Align the backplane with the hooks and guide pins on the system. Slide the backplane towards the back and tighten the screws to secure it in place.

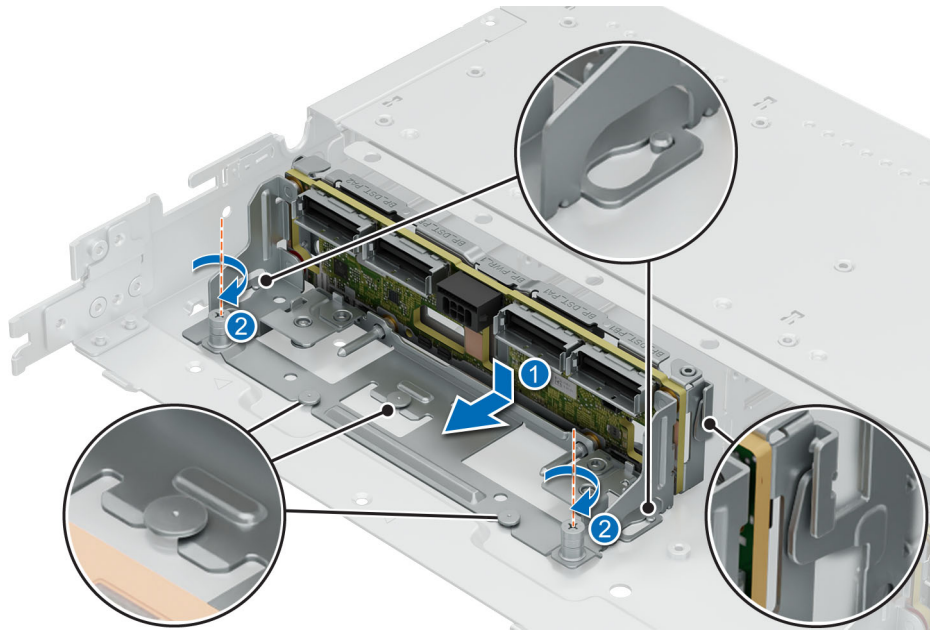

**Figure 79. Installing the PERC backplane**

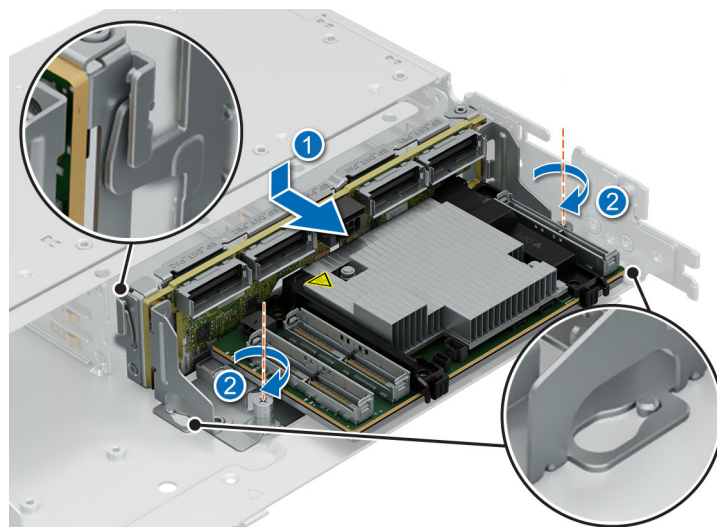

**Figure 80. Installing the PERC backplane with H975i module**

### Next steps

1. Connect all the cables, and ensure that all the cables are routed through the respective cable clip.

**i** **NOTE:** See [cable routing](#) section.

2. If removed, [install the L-type processor heatsink module](#) .

**i** **NOTE:** The L-type heatsink prevents the installation of E3.S backplane connectors from the system board.

3. [Install the EDSFF E3.S drives](#) .
4. [Install the drive backplane cover](#).
5. [Install the cooling fans](#).
6. [Install the front bezel](#).
7. Follow the procedure listed in [After working inside your system](#).

## Side wall brackets

### Removing the side wall bracket

There are two side wall brackets on either side of the system. The procedure to remove is similar.

#### Prerequisites

1. Follow the safety guidelines listed in the [Safety instructions](#).
2. Follow the procedure listed in the [Before working inside your system](#).
3. [Remove the drive backplane cover](#).
4. [Remove the cooling fans](#).

**i** **NOTE:** Ensure that you note the routing of the cables as you remove them from the system board. Route the cables properly when you replace them to prevent the cables from being pinched or crimped.

#### Steps

1. Press the side tabs to release the side wall cable holder.

**i** **NOTE:** Move the cables out of the side wall cable holder.

2. Press the center tab to release the bracket from the chassis, and lift it away from the system.

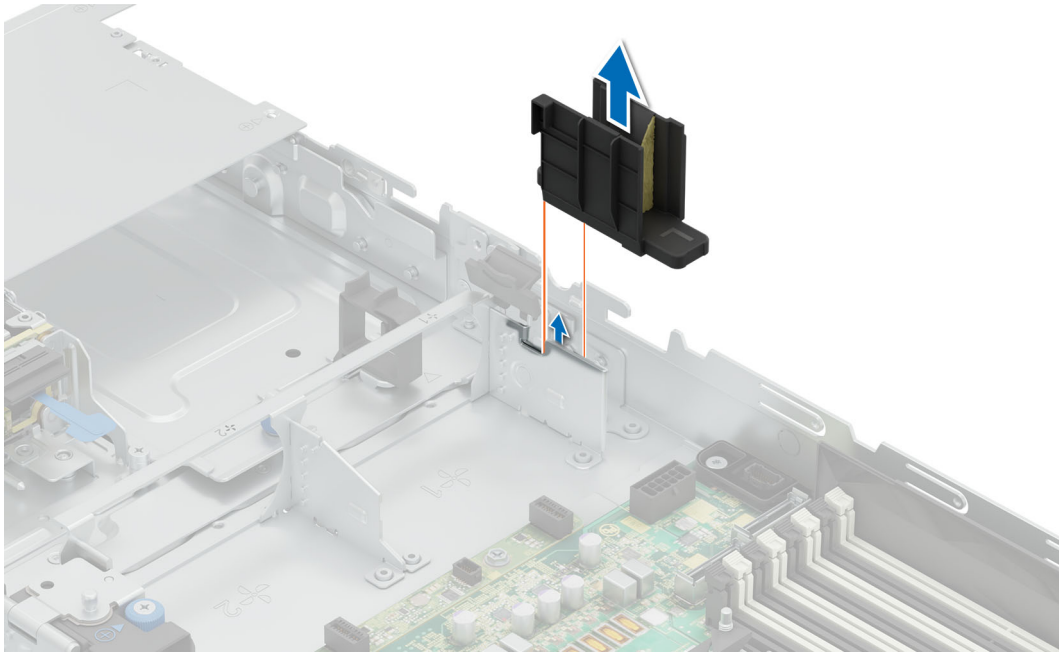

**Figure 81. Removing the side wall bracket**

#### Next steps

1. [Replace the side wall bracket.](#)

## Installing the side wall bracket

There are two side wall brackets on either side of the system. The procedure to install is similar.

#### Prerequisites

1. Follow the safety guidelines listed in the [Safety instructions](#).
2. Follow the procedure listed in the [Before working inside your system](#).
3. If required, [Remove the drive backplane cover](#).
4. [Remove the cooling fans](#).

**NOTE:** Ensure that you note the routing of the cables as you remove them from the system board. Route the cables properly when you replace them to prevent the cables from being pinched or crimped.

#### Steps

1. Align the guide slots on the side wall bracket with the guides on the system and slide until the cover is seated firmly.
2. Route the cables through the side wall cable holder.

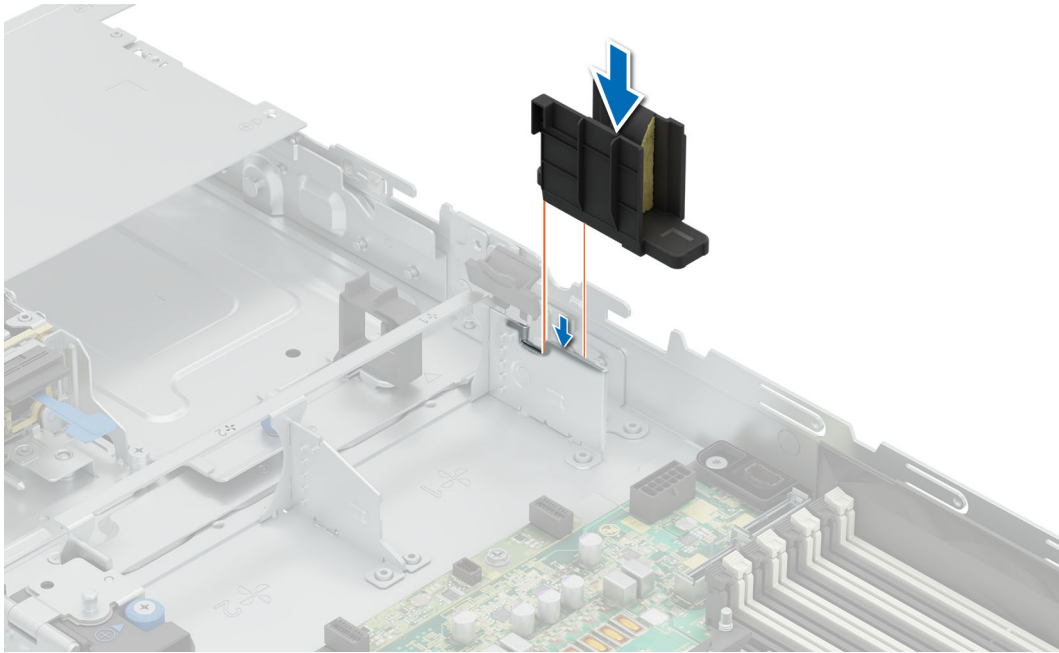

**Figure 82. Installing the side wall bracket**

#### Next steps

1. [Install the cooling fans.](#)
2. If removed, [Install the drive backplane cover.](#)
3. Follow the procedure listed in the [After working inside your system.](#)

## Middle bracket

### Removing the cables from the middle bracket

#### Prerequisites

1. Follow the safety guidelines listed in the [Safety instructions.](#)
2. Follow the procedure listed in the [Before working inside your system.](#)
3. If required, [Remove the drive backplane cover.](#)
4. [Remove the cooling fans.](#)

**i** **NOTE:** Ensure that you note the routing of the cables as you remove them from the system board. Route the cables properly when you replace them to prevent the cables from being pinched or crimped.

#### Steps

1. Loosen the captive screw using a Phillips 2 screwdriver.
2. Open the middle metal cover and the middle cable holder.

**i** **NOTE:** Remove the cables sequentially from top to bottom.

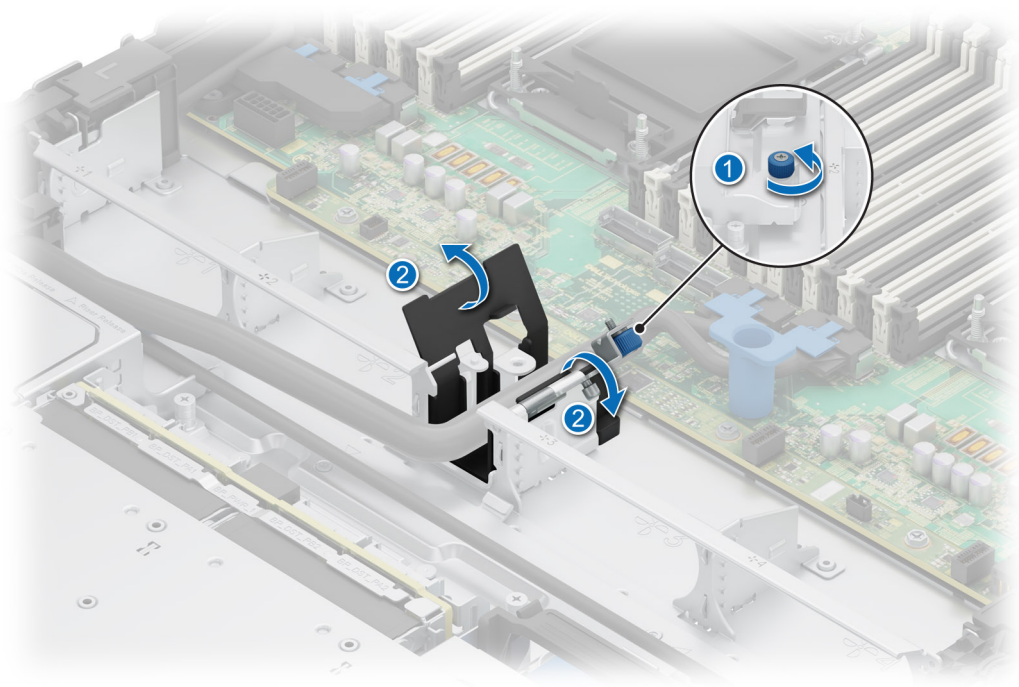

**Figure 83. Removing the middle bracket**

#### Next steps

1. [Replace the cables into the middle bracket](#) .

## Installing the cables into the middle bracket

#### Prerequisites

1. Follow the safety guidelines listed in the [Safety instructions](#).
2. Follow the procedure listed in the [Before working inside your system](#).
3. If required, [remove the drive backplane cover](#).
4. [Remove the cooling fans](#).

**i** **NOTE:** Ensure that you note the routing of the cables as you remove them from the system board. Route the cables properly when you replace them to prevent the cables from being pinched or crimped.

#### Steps

1. Open the middle metal cover and the middle cable holder.

**i** **NOTE:** Route the cables through the middle cable holder.

2. Close the middle cable holder and the metal cover, and fasten the captive screw using a Phillips 2 screwdriver.

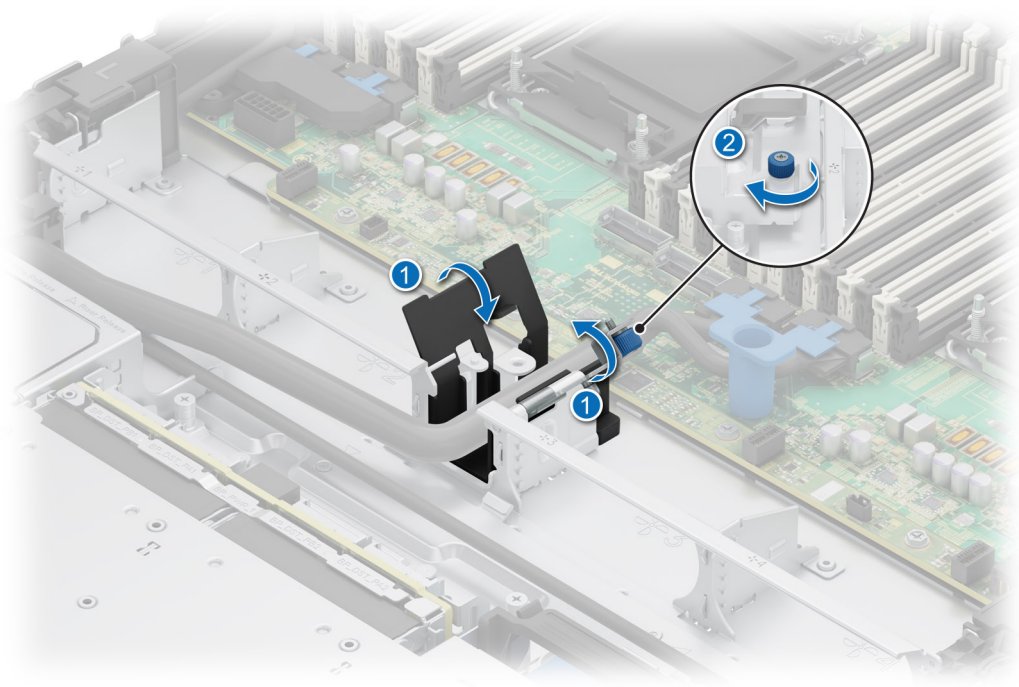
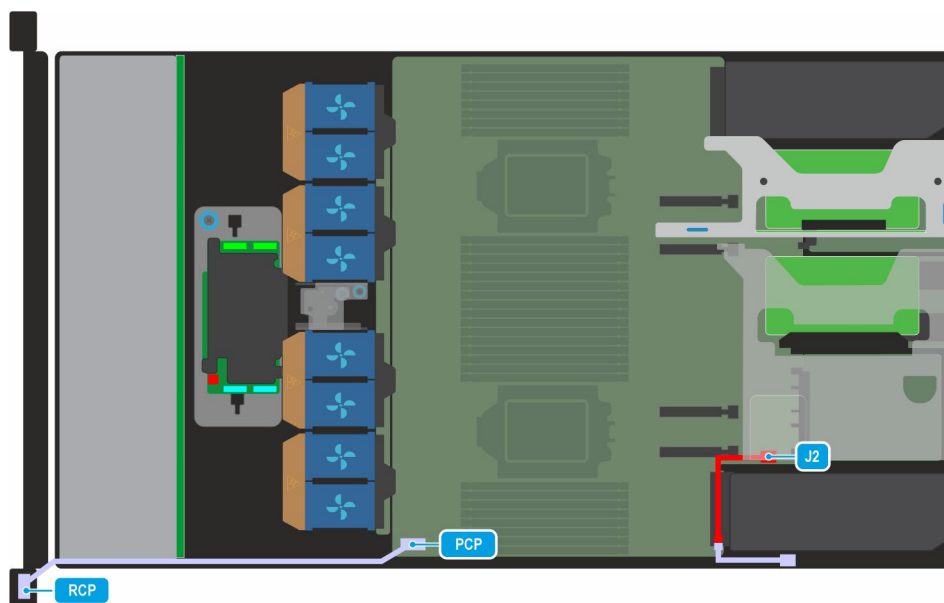

**Figure 84. Installing the middle bracket**

**Next steps**

1. Install the cooling fans.
2. Install the drive backplane cover.
3. Follow the procedure listed in the *After working inside your system.*

## Cable routing

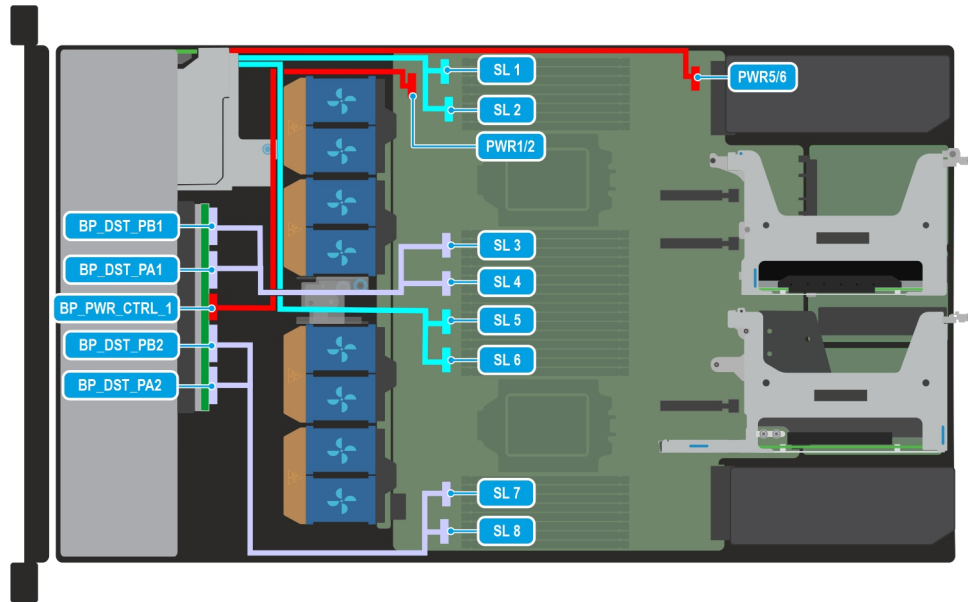

**Figure 85. C0-02: No BP configuration.**

**Table 52. C0-02: No BP configuration.**

Order	From	To
1	PCP (signal connector on system board)	Right control panel (RCP)
2	Intrusion switch	J2 (signal connector on system board)

**NOTE:** The intrusion switch connects to the J2 connector through the additional dongle cable.

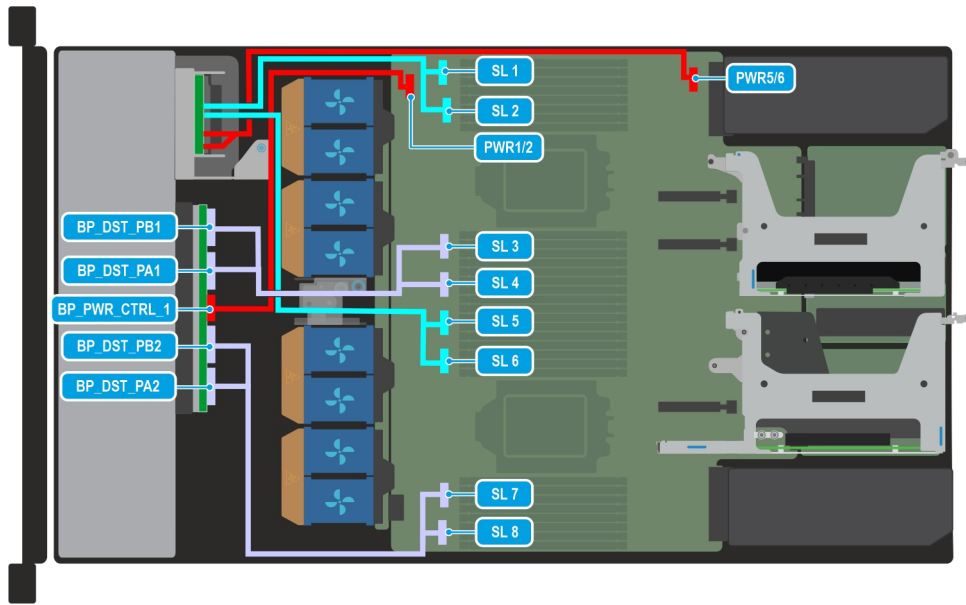

**Figure 86. C01-01-RC1 : FIO 8 x E3.S (G5x4 NVMe Direct Connect)**

**NOTE:** Follow the sequential order as shown in the table to remove the cables, to install the cables follow the reverse sequential order.

**Table 53. C01-01-RC1 : FIO 8 x E3.S (G5x4 NVMe Direct Connect)**

Order	From	To
1	SL3 (signal connector on system board)	BP_PB1 (backplane signal connector)
2	SL4 (signal connector on system board)	BP_PA1 (backplane signal connector)
3	SL7 (signal connector on system board)	BP_PB2 (backplane signal connector)
4	SL8 (signal connector on system board)	BP_PA2 (backplane signal connector)
5	PWR1/2 (system board power connector)	BP_PWR_CTRL_1 (backplane power connector)
6	SL1/SL2 (signal connectors on system board)	RF1a (front riser cable, Slot 31)
7	SL5/SL6 (signal connectors on system board)	RF1a (front riser cable, Slot 32)
8	PWR5/6 (system board power connectors)	RF1a (front riser PWR, Slot 31,32)

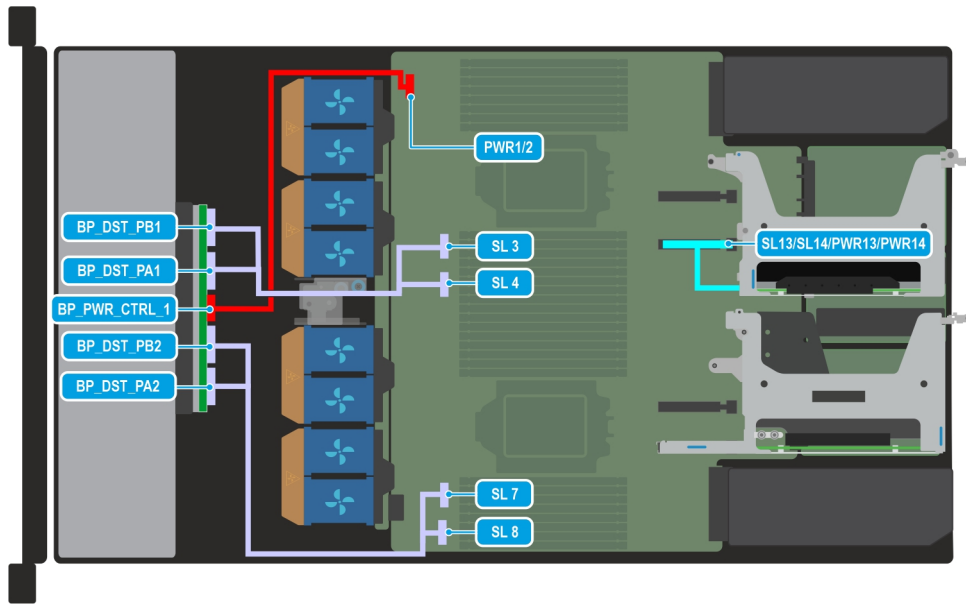

**Figure 87. C01-01-RC2: FIO 8 x E3.S (G5x4 NVMe Direct Connect)**

**NOTE:** Follow the sequential order as shown in the table to remove the cables, to install the cables follow the reverse sequential order.

**Table 54. C01-01-RC2: FIO 8 x E3.S (G5x4 NVMe Direct Connect)**

Order	From	To
1	SL3 (signal connector on system board)	BP_PB1 (backplane signal connector)
2	SL4 (signal connector on system board)	BP_PA1 (backplane signal connector)
3	SL7 (signal connector on system board)	BP_PB2 (backplane signal connector)
4	SL8 (signal connector on system board)	BP_PA2 (backplane signal connector)
5	PWR1/2 (system board power connector)	BP_PWR_CTRL_1 (backplane power connector)
6	SL1/SL2 (signal connectors on system board)	RF1b (front OCP, Slot 31)
7	SL5/SL6 (signal connectors on system board)	RF1b (front OCP, Slot 32)
8	PWR5/6 (system board power connector)	RF1b (front OCP PWR, Slot 31,32)

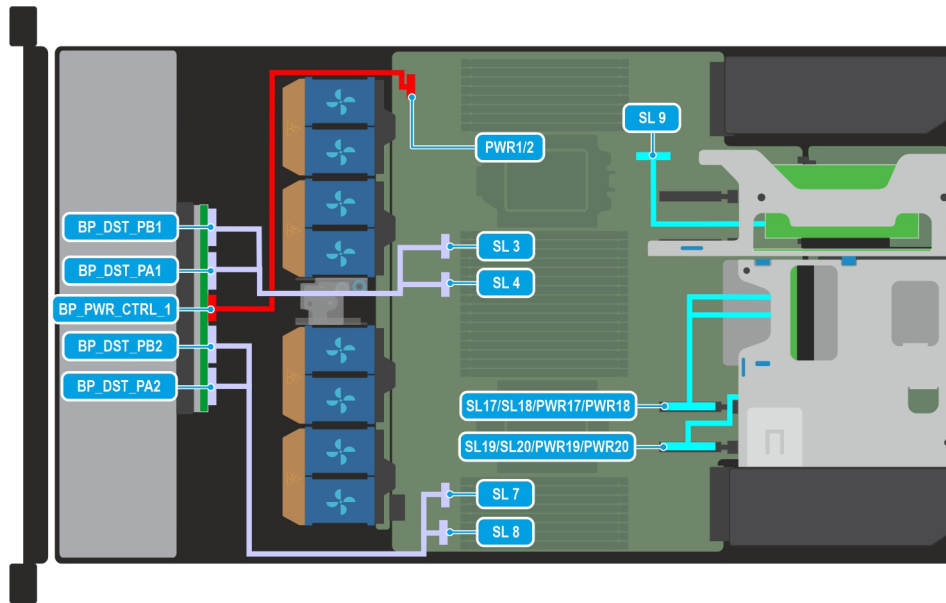

**Figure 88. C01-01-RC5: FIO 8 x E3.S (G5x4 NVMe Direct Connect)**

**NOTE:** Follow the sequential order as shown in the table to remove the cables, to install the cables follow the reverse sequential order.

**Table 55. C01-01-RC5: FIO 8 x E3.S (G5x4 NVMe Direct Connect)**

Order	From	To
1	SL3 (signal connector on system board)	BP_PB1 (backplane signal connector)
2	SL4 (signal connector on system board)	BP_PA1 (backplane signal connector)
3	SL7 (signal connector on system board)	BP_PB2 (backplane signal connector)
4	SL8 (signal connector on system board)	BP_PA2 (backplane signal connector)
5	PWR1/2 (system board power connector)	BP_PWR_CTRL_1 (backplane power connector)
6	SL13/SL14/PWR13/PWR14 (signal connector on system board)	R4b (riser cable, Slot 4)

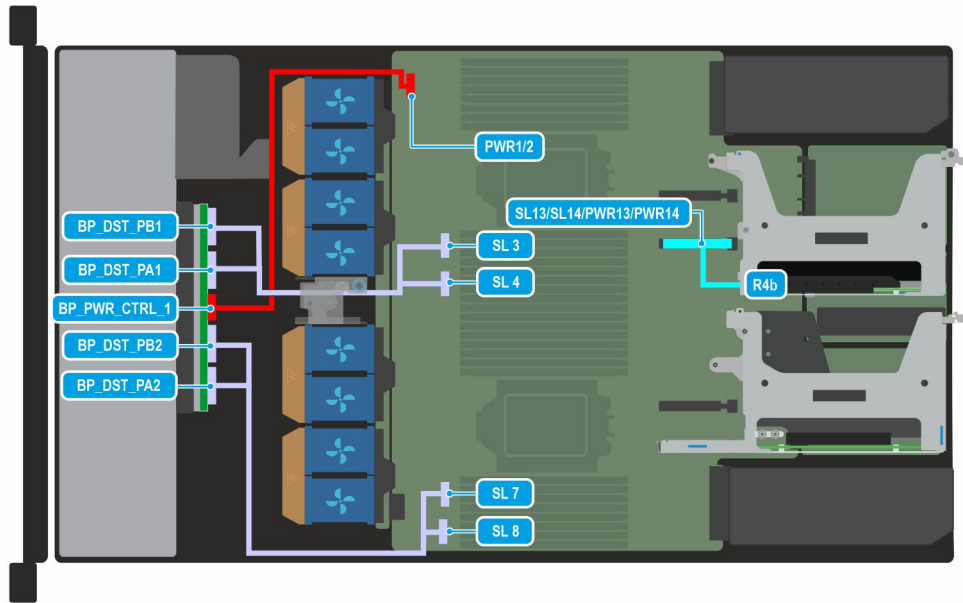

**Figure 89. C01-01-RC6: FIO 8 x E3.S (G5x4 NVMe Direct Connect)**

**NOTE:** Follow the sequential order as shown in the table to remove the cables, to install the cables follow the reverse sequential order.

**Table 56. C01-01-RC6: FIO 8 x E3.S (G5x4 NVMe Direct Connect)**

Order	From	To
1	SL3 (signal connector on system board)	BP_PB1 (backplane signal connector)
2	SL4 (signal connector on system board)	BP_PA1 (backplane signal connector)
3	SL7 (signal connector on system board)	BP_PB2 (backplane signal connector)
4	SL8 (signal connector on system board)	BP_PA2 (backplane signal connector)
5	PWR1/2 (system board power connector)	BP_PWR_CTRL_1 (backplane power connector)
6	SL19/SL20/PWR19/PWR20 (signal connector on system board)	R2f (riser cable, Slot 1)
7	SL17/SL18/PWR17/PWR18 (signal connector on system board)	OCP, Slot 2
8	SL9 (signal connector on system board)	SL21 (signal connector on system board)



**Figure 90. C01-02-RC5: FIO 8 x E3.S (G5x4 NVMe Direct Connect).**

**NOTE:** Follow the sequential order as shown in the table to remove the cables, to install the cables follow the reverse sequential order.

**Table 57. C01-02-RC5: FIO 8 x E3.S (G5x4 NVMe Direct Connect).**

Order	From	To
1	SL3 (signal connector on system board)	BP_PB1 (backplane signal connector)
2	SL4 (signal connector on system board)	BP_PA1 (backplane signal connector)
3	SL7 (signal connector on system board)	BP_PB2 (backplane signal connector)
4	SL8 (signal connector on system board)	BP_PA2 (backplane signal connector)
5	PWR1/2 (system board power connector)	BP_PWR_CTRL_1 (backplane power connector)
6	SL13/SL14/PWR13/PWR14	R4b (riser cable, Slot 4)

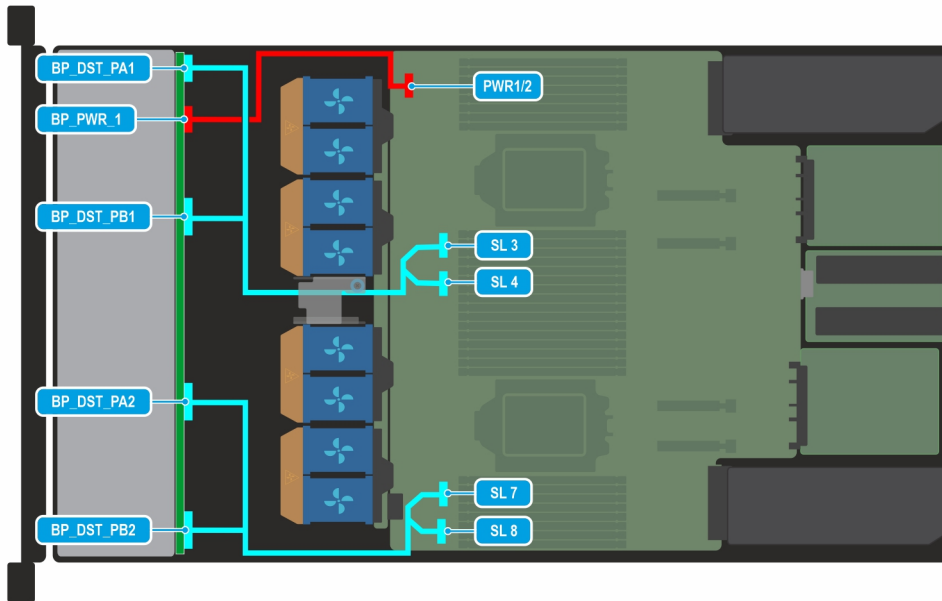

Figure 91. C02-01: 8 x 2.5-inch (G4 NVMe Direct Connect)

**NOTE:** Follow the sequential order as shown in the table to remove the cables, to install the cables follow the reverse sequential order.

Table 58. C02-01: 8 x 2.5-inch (G4 NVMe Direct Connect)

Order	From	To
1	PWR1/2 (system board power connector)	BP_PWR_1 (backplane power connector)
2	SL3 (signal connector on system board)	BP_DST_PA1 (backplane signal connector)
3	SL4 (signal connector on system board)	BP_DST_PB1 (backplane signal connector)
4	SL7 (signal connector on system board)	BP_DST_PA2 (backplane signal connector)
5	SL8 (signal connector on system board)	BP_DST_PB2 (backplane signal connector)

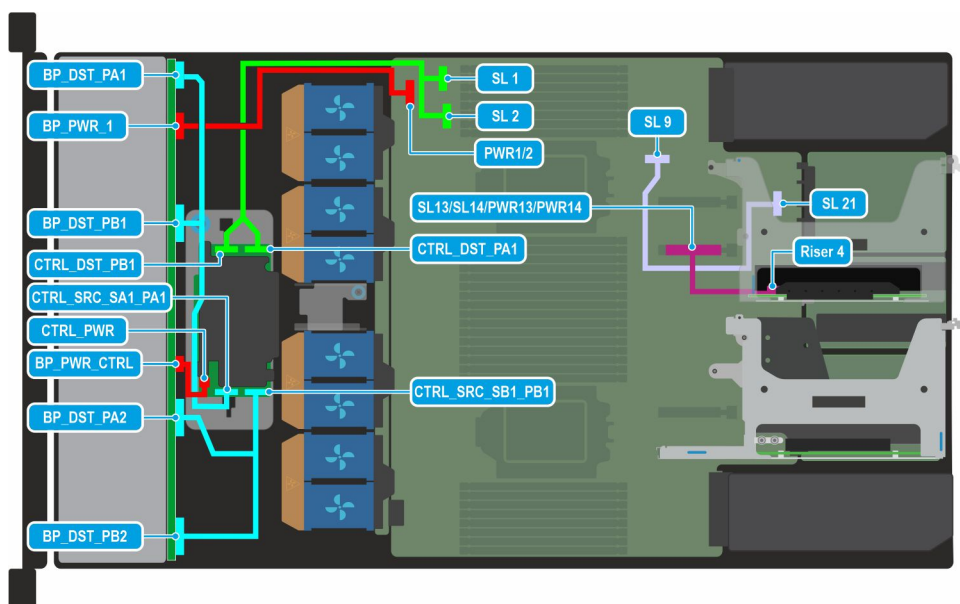
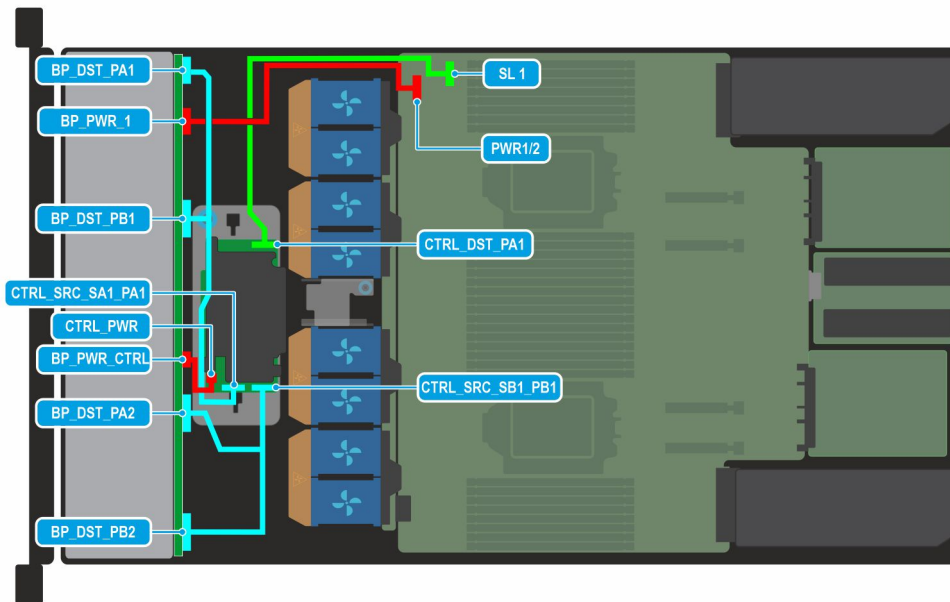

Figure 92. C02-02: 8 x 2.5-inch (G4 NVMe RAID)

**NOTE:** Follow the sequential order as shown in the table to remove the cables, to install the cables follow the reverse sequential order.

**Table 59. C02-02: 8 x 2.5-inch (G4 NVMe RAID)**

Order	From	To
1	SL13/SL14/PWR13/PWR14	Riser 4
2	SL1/SL2 (signal connector on system board)	CTRL_DST_PA1 and CTRL_DST_PA1 (controller connectors on front PERC)
3	PWR1/2 (system board power connector)	BP_PWR_1 (backplane power connector)
4	CTRL_PWR (front PERC power connector)	BP_PWR_CTRL (backplane power controller)
5	CTRL_SRC_SA1_PA1(controller connector on front PERC)	BP_DST_PA1 and BP_DST_PB1 (backplane signal connectors)
6	CTRL_SRC_SB1_PB1 (controller connector on front PERC)	BP_DST_PA2 and BP_DST_PB2 (backplane signal connectors)
7	SL9 (signal connector on system board)	SL21 (signal connector on system board)

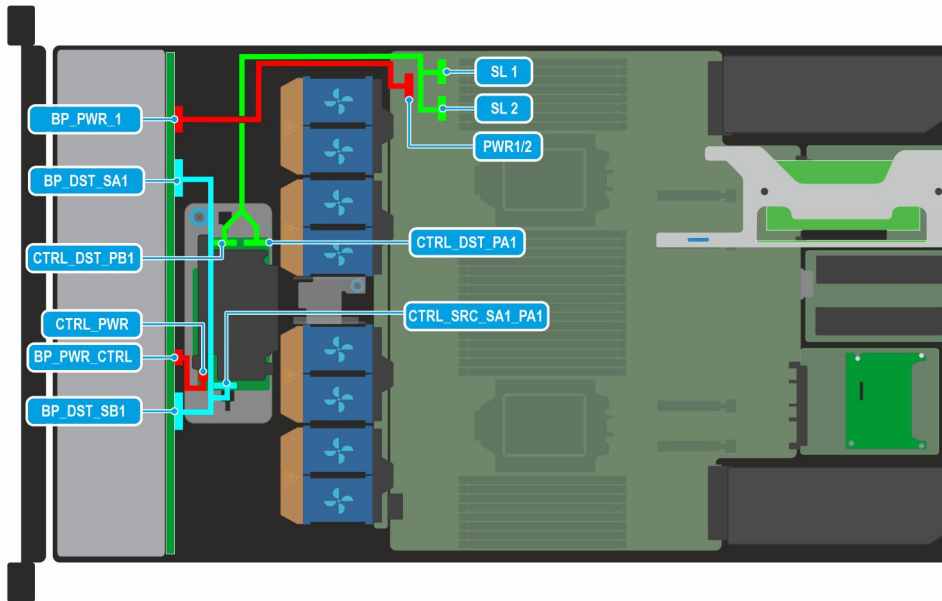

**Figure 93. C02-03: 8 x 2.5-inch (G4 NVMe RAID).**

**NOTE:** Follow the sequential order as shown in the table to remove the cables, to install the cables follow the reverse sequential order.

**Table 60. C02-03: 8 x 2.5-inch (G4 NVMe RAID).**

Order	From	To
1	PWR1/2 (system board power connector)	BP_PWR_1 (backplane power connector)
2	CTRL_SRC_SA1_PA1 (controller connector on front PERC)	BP_DST_PA1 and BP_DST_PB1 (backplane signal connectors)
3	CTRL_SRC_SB1_PB1 (controller connector on front PERC)	BP_DST_PA2 and BP_DST_PB2 (backplane signal connectors)
4	SL1 (signal connector on system board)	CTRL_DST_PA1 (controller connector on front PERC)
5	BP_PWR_CTRL (backplane power controller)	CTRL_PWR (front PERC power connector)

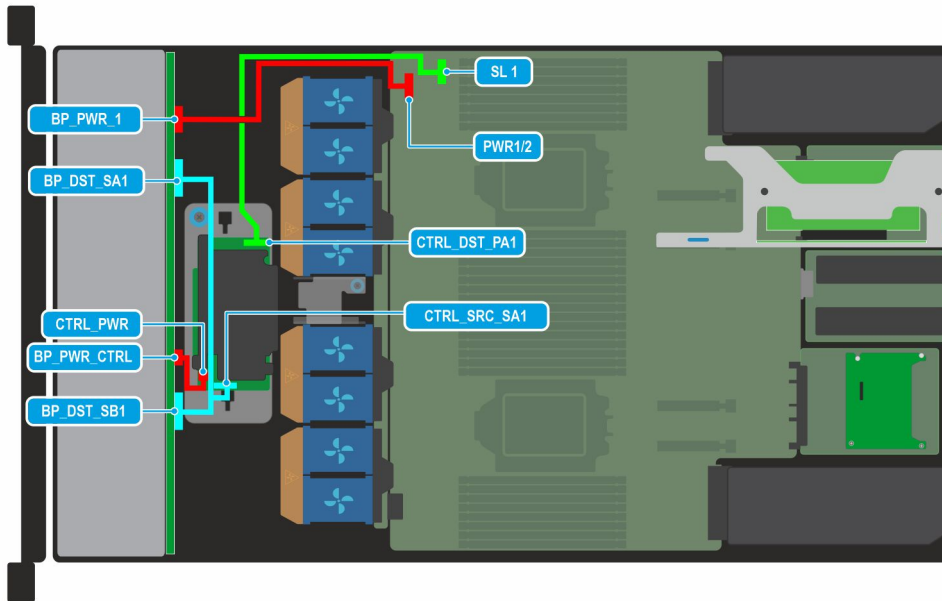

**Figure 94. C02-05-RC5: 8 x 2.5-inch (SAS4/SATA).**

**NOTE:** Follow the sequential order as shown in the table to remove the cables, to install the cables follow the reverse sequential order.

**Table 61. C02-05-RC5: 8 x 2.5-inch (SAS4/SATA).**

Order	From	To
1	PWR1/2 (system board power connector)	BP_PWR_1 (backplane power connector)
2	SL1 (signal connector on system board)	CTRL_DST_PA1 (controller connector on front PERC)
3	SL2 (signal connector on system board)	CTRL_DST_PB1 (controller connector on front PERC)
5	BP_PWR_CTRL (backplane power controller)	CTRL_PWR (front PERC power connector)
4	CTRL_SRC_SA1_PA1(controller connector on front PERC)	BP_DST_SA1 and BP_DST_SB1 (backplane signal connectors)

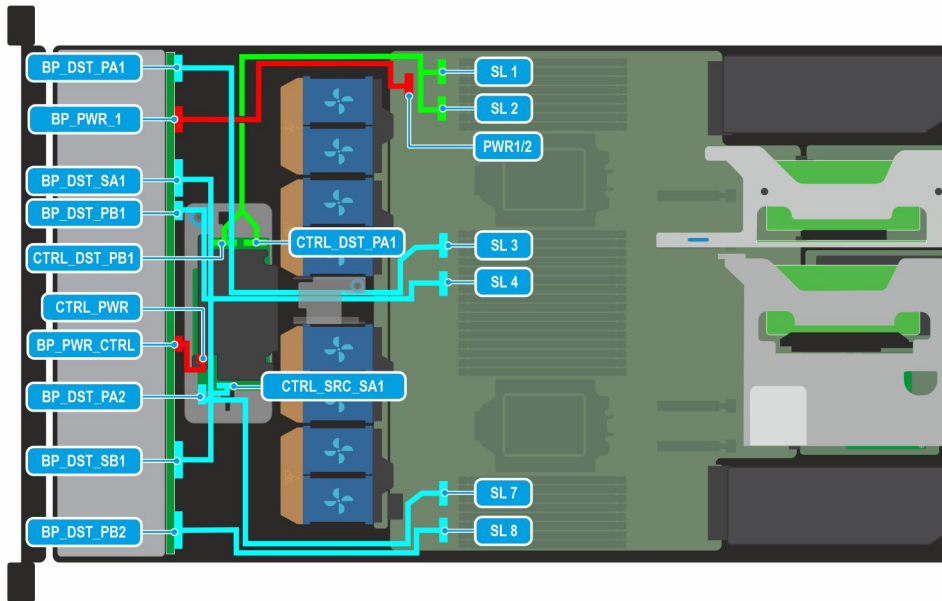

**Figure 95. C02-06 : 8 x 2.5-inch (SAS4/SATA).**

**NOTE:** Follow the sequential order as shown in the table to remove the cables, to install the cables follow the reverse sequential order.

**Table 62. C02-06 : 8 x 2.5-inch (SAS4/SATA).**

Order	From	To
1	PWR_1/2 (system board power connector)	BP_PWR_1 (backplane power connector)
2	SL1 (signal connector on system board)	CTRL_DST_PA1 (controller connector on front PERC)
3	BP_PWR_CTRL (backplane power controller)	CTRL_PWR (front PERC power connector)
4	BP_DST_SA1 and BP_DST_SB1 (backplane signal connectors)	CTRL_SRC_SA1 (controller connector on front PERC)

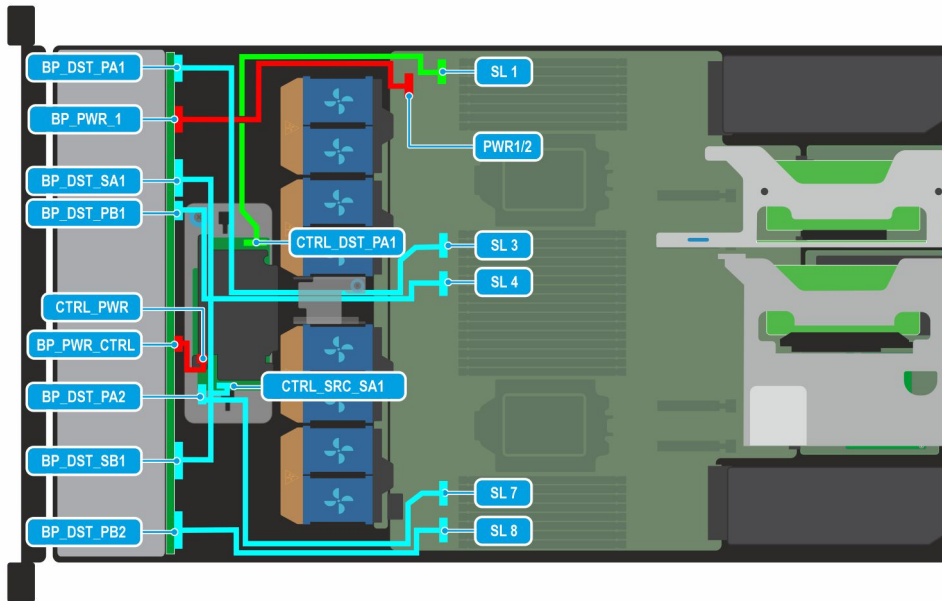

**Figure 96. C02-08 : 8 x 2.5-inch Universal.**

**NOTE:** Follow the sequential order as shown in the table to remove the cables, to install the cables follow the reverse sequential order.

**Table 63. C02-08 : 8 x 2.5-inch Universal.**

Order	From	To
1	SL3 (signal connector on system board)	BP_DST_PA1 (backplane signal connector)
2	SL4 (signal connector on system board)	BP_DST_PB1 (backplane signal connector)
3	SL7 (signal connector on system board)	BP_DST_PA2 (backplane signal connector)
4	SL8 (signal connector on system board)	BP_DST_PB2 (backplane signal connector)
5	PWR1/2 (system board power connector)	BP_PWR_1 (backplane power connector)
6	SL1 (signal connector on system board)	CTRL_DST_PA1 (controller connector on front PERC)
7	SL2 (signal connector on system board)	CTRL_DST_PB1 (controller connector on front PERC)
8	BP_PWR_CTRL (backplane power controller)	CTRL_PWR (front PERC power connector)
9	BP_DST_SA1 and BP_DST_SB1 (backplane signal connectors)	CTRL_SRC_SA1 (controller connector on front PERC)

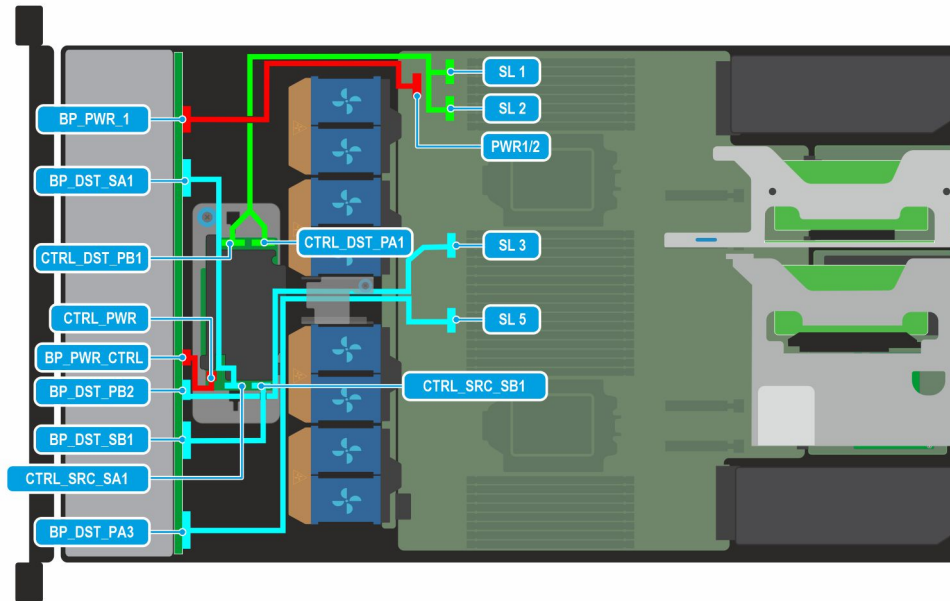

**Figure 97. C02-09 : 8 x 2.5-inch Universal.**

**NOTE:** Follow the sequential order as shown in the table to remove the cables, to install the cables follow the reverse sequential order.

**Table 64. C02-09 : 8 x 2.5-inch Universal.**

Order	From	To
1	SL3 (signal connector on system board)	BP_DST_PA1 (backplane signal connector)
2	SL4 (signal connector on system board)	BP_DST_PB1 (backplane signal connector)
3	SL7 (signal connector on system board)	BP_DST_PA2 (backplane signal connector)
4	SL8 (signal connector on system board)	BP_DST_PB2 (backplane signal connector)
5	PWR1/2 (system board power connector)	BP_PWR_1 (backplane power connector)
6	BP_PWR_CTRL (backplane power controller)	CTRL_PWR (front PERC power connector)
7	SL1 (signal connector on system board)	CTRL_DST_PA1 (controller connector on front PERC)
8	BP_DST_SA1 and BP_DST_SB1 (backplane signal connectors)	CTRL_SRC_SA1 (controller connector on front PERC)



**Figure 98. C03-01 : 10 x 2.5-inch SAS4/SATA with Universal.**

**NOTE:** Follow the sequential order as shown in the table to remove the cables, to install the cables follow the reverse sequential order.

**Table 65. C03-01 : 10 x 2.5-inch SAS4/SATA with 4 Universal.**

Order	From	To
1	SL1 (signal connector on system board)	CTRL_DST_PA1 (controller connector on front PERC)
2	SL2 (signal connector on system board)	CTRL_DST_PB1 (controller connector on front PERC)
3	BP_PWR_CTRL (backplane power controller)	CTRL_PWR (front PERC power connector)
4	BP_DST_SB1 (backplane signal connector)	CTRL_SRC_SB1 (controller connector on front PERC)
5	PWR1/2 (system board power connector)	BP_PWR_1 (backplane power connector)
6	BP_DST_SA1 (backplane signal connector)	CTRL_SRC_SA1 (controller connector on front PERC)
7	SL3 (signal connector on system board)	BP_DST_PB2 (backplane signal connector)
8	SL5 (signal connector on system board)	BP_DST_PA3 (backplane signal connector)

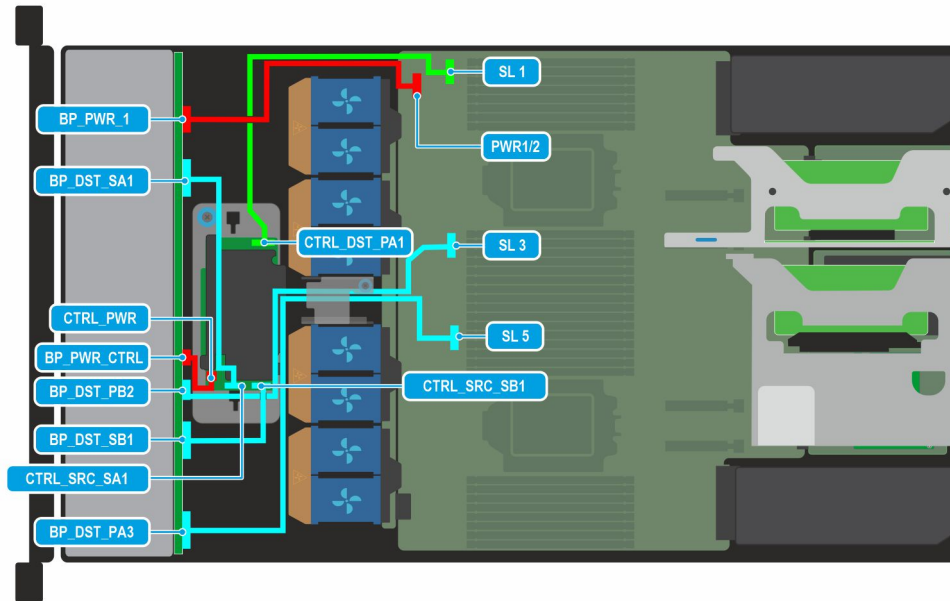

Figure 99. C03-02 : 10 x 2.5-inch SAS4/SATA with 4 Universal.

**NOTE:** Follow the sequential order as shown in the table to remove the cables, to install the cables follow the reverse sequential order.

Table 66. C03-02 : 10 x 2.5-inch SAS4/SATA with 4 Universal.

Order	From	To
1	BP_PWR_CTRL (backplane power controller)	CTRL_PWR (front PERC power connector)
2	SL1 (signal connector on system board)	CTRL_DST_PA1 (controller connector on front PERC)
3	BP_DST_SB1 (backplane signal connector)	CTRL_SRC_SB1 (controller connector on front PERC)
4	PWR_1/2 (system board power connector)	BP_PWR_1 (backplane power connector)
5	BP_DST_SA1 (backplane signal connector)	CTRL_SRC_SA1 (controller connector on front PERC)
6	SL3 (signal connector on system board)	BP_DST_PB2 (backplane signal connector)
7	SL5 (signal connector on system board)	BP_DST_PA3 (backplane signal connector)

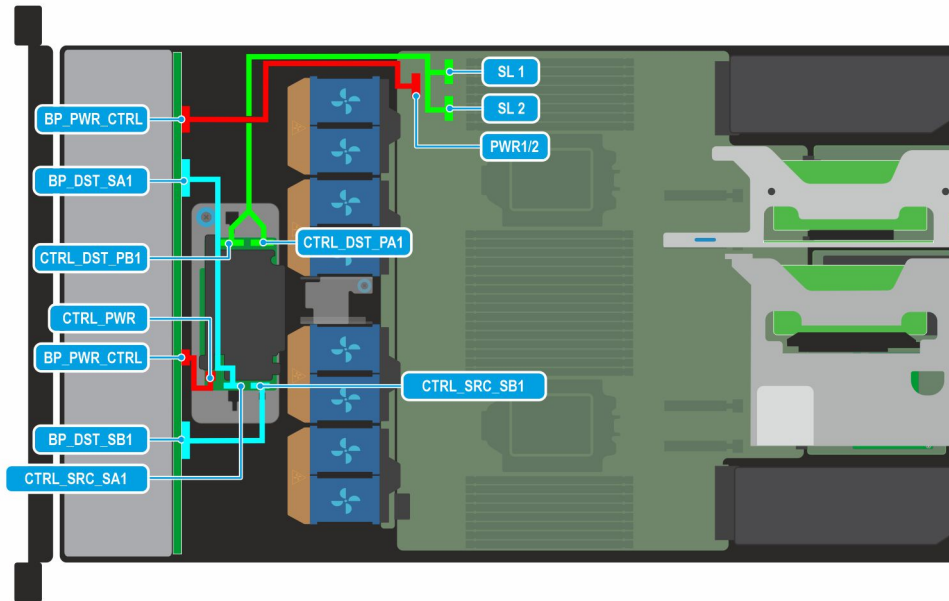
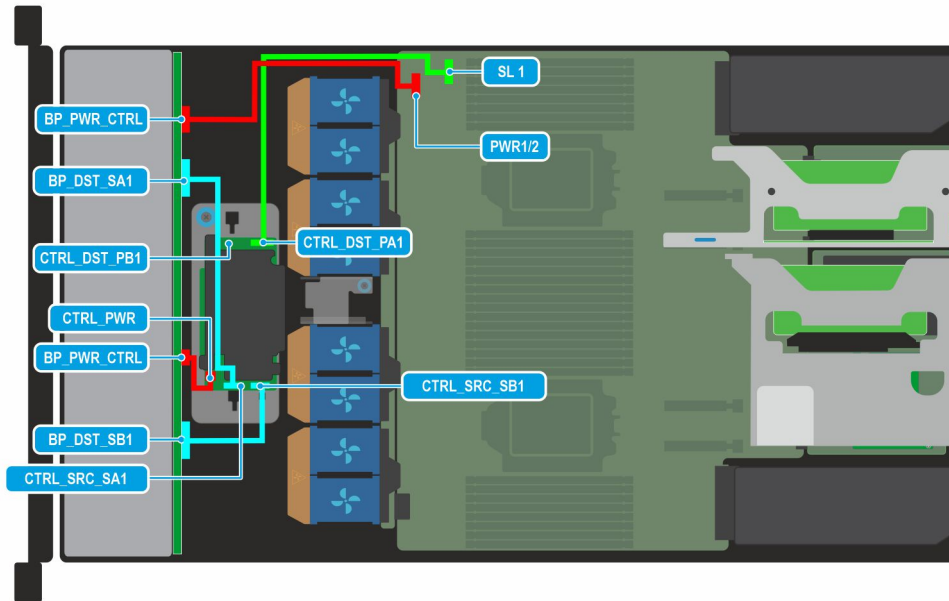

Figure 100. C03-04 : 10 x 2.5-inch SAS4/SATA.

**NOTE:** Follow the sequential order as shown in the table to remove the cables, to install the cables follow the reverse sequential order.

Table 67. C03-04 : 10 x 2.5-inch SAS4/SATA.

Order	From	To
1	SL1 (signal connector on system board)	CTRL_DST_PA1 (controller connector on front PERC)
2	SL2 (signal connector on system board)	CTRL_DST_PB1 (controller connector on front PERC)
3	BP_PWR_CTRL (backplane power controller)	CTRL_PWR (front PERC power connector)
4	BP_DST_SB1 (backplane signal connector)	CTRL_SRC_SB1 (controller connector on front PERC)
5	PWR_1/2 (system board power connector)	BP_PWR_CTRL (backplane power connector)
6	BP_DST_SA1 (backplane signal connector)	CTRL_SRC_SA1 (controller connector on front PERC)

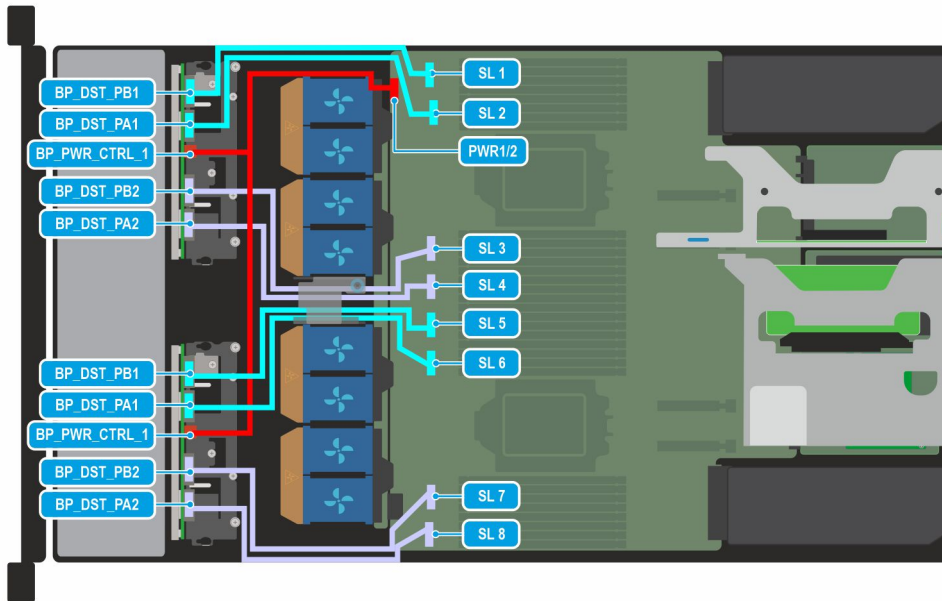

**Figure 101. C03-05 : 10 x 2.5-inch SAS4/SATA.**

**NOTE:** Follow the sequential order as shown in the table to remove the cables, to install the cables follow the reverse sequential order.

**Table 68. C03-05 : 10 x 2.5-inch SAS4/SATA.**

Order	From	To
1	BP_PWR_CTRL (backplane power controller)	CTRL_PWR (front PERC power connector)
2	SL1 (signal connector on system board)	CTRL_DST_PA1 (controller connector on front PERC)
3	BP_DST_SB1 (backplane signal connector)	CTRL_SRC_SB1 (controller connector on front PERC)
4	PWR_1/2 (system board power connector)	BP_PWR_CTRL (backplane power connector)
5	BP_DST_SA1 (backplane signal connector)	CTRL_SRC_SA1 (controller connector on front PERC)

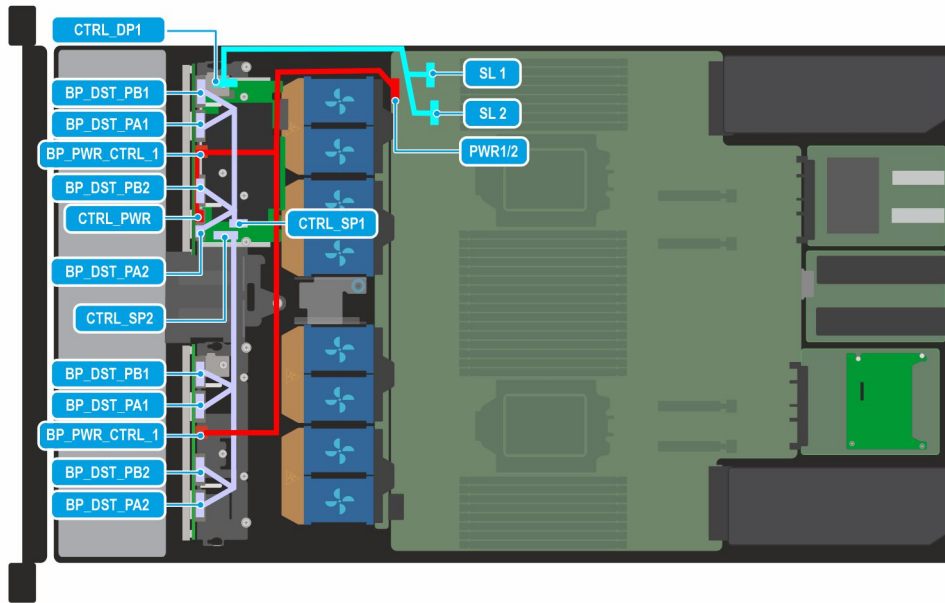

**Figure 102. C04-01 : 16 x E3.S (G5x4 NVMe Direct Connect).**

**NOTE:** Follow the sequential order as shown in the table to remove the cables, to install the cables follow the reverse sequential order.

**Table 69. C04-01 : 16 x E3.S (G5x4 NVMe Direct Connect).**

Order	From	To
1	PWR1/2 (system board power connector)	BP_PWR_CTRL_1 and BP_PWR_CTRL_1 (backplane power connectors)
2	SL1 (signal connector on system board)	BP_DST_PB1 (backplane signal connector)
3	SL2 (signal connector on system board)	BP_DST_PA1 (backplane signal connector)
4	SL3 (signal connector on system board)	BP_DST_PB2 (backplane signal connector)
5	SL4 (signal connector on system board)	BP_DST_PA2 (backplane signal connector)
6	SL5 (signal connector on system board)	BP_DST_PB1 (backplane signal connector)
7	SL6 (signal connector on system board)	BP_DST_PA1 (backplane signal connector)
8	SL7 (signal connector on system board)	BP_DST_PB2 (backplane signal connector)
9	SL8 (signal connector on system board)	BP_DST_PA2 (backplane signal connector)

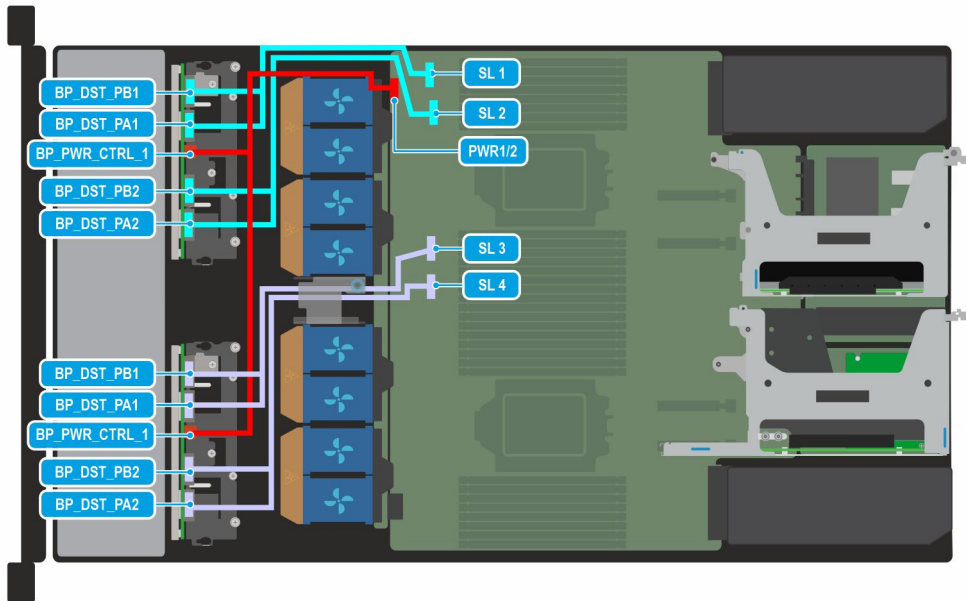

**Figure 103. C04-02 : 16 x E3.S (G5x2 NVMe Single RAID)**

**NOTE:** Follow the sequential order as shown in the table to remove the cables, to install the cables follow the reverse sequential order.

**Table 70. C04-02 : 16 x E3.S (G5x2 NVMe Single RAID)**

Order	From	To
1	SL1/SL2 (signal connector on system board)	CTRL_DP1 (controller connector on front PERC)
2	BP_DST_PB1/BP_DST_PA1/BP_DST_PB2/ BP_DST_PA2 (backplane signal connectors)	CTRL_SP1 (controller connector on front PERC)
3	BP_DST_PB1/BP_DST_PA1/BP_DST_PB2/ BP_DST_PA2 (backplane signal connectors)	CTRL_SP2 (controller connector on front PERC)
4	PWR1/2 (system board power connector)	BP_PWR_CTRL_1 and BP_PWR_CTRL_1 (backplane power connectors) and CTRL_PWR (front PERC power connector)

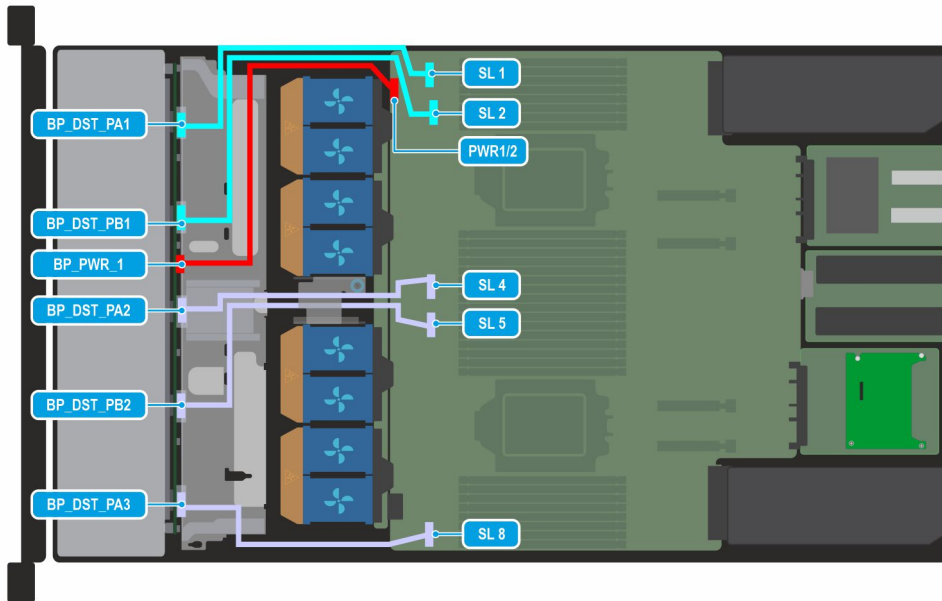

**Figure 104. C04-03 : 16 x E3.S (G5x2 NVMe Direct Connect).**

**NOTE:** Follow the sequential order as shown in the table to remove the cables, to install the cables follow the reverse sequential order.

**Table 71. C04-03 : 16 x E3.S (G5x2 NVMe Direct Connect).**

Order	From	To
1	PWR1/2 (system board power connector)	BP_PWR_CTRL_1 and BP_PWR_CTRL_1 (backplane power connectors)
2	SL1 (signal connector on system board)	BP_DST_PA1 and BP_DST_PB1 (backplane signal connectors)
3	SL2 (signal connector on system board)	BP_DST_PA2 and BP_DST_PB2 (backplane signal connectors)
4	SL3 (signal connector on system board)	BP_DST_PA1 and BP_DST_PB1 (backplane signal connectors)
5	SL4 (signal connector on system board)	BP_DST_PA2 and BP_DST_PB2 (backplane signal connectors)

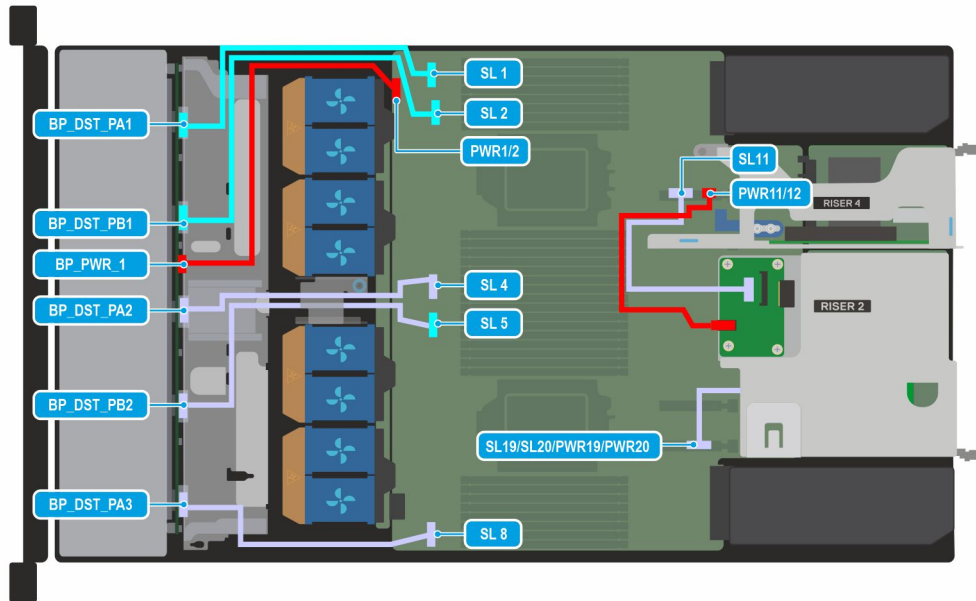

**Figure 105. C05-01 : 20 x E3.S (G5x2 NVMe Direct Connect).**

**NOTE:** Follow the sequential order as shown in the table to remove the cables, to install the cables follow the reverse sequential order.

**Table 72. C05-01 : 20 x E3.S (G5x2 NVMe Direct Connect).**

Order	From	To
1	PWR1/2 (system board power connector)	BP_PWR_1 (backplane power connector)
2	SL1 (signal connector on system board)	BP_DST_PA1 (backplane signal connector)
3	SL2 (signal connector on system board)	BP_DST_PB1 (backplane signal connector)
4	SL4 (signal connector on system board)	BP_DST_PA2 (backplane signal connector)
5	SL5 (signal connector on system board)	BP_DST_PB2 (backplane signal connector)
6	SL8 (signal connector on system board)	BP_DST_PA3 (backplane signal connector)



**Figure 106. C05-03 : 20 x E3.S (G5x2 NVMe Direct Connect) + 2 x E3.S (G5x4 NVMe direct).**

**NOTE:** Follow the sequential order as shown in the table to remove the cables, to install the cables follow the reverse sequential order.

**Table 73. C05-03 : 20 x E3.S (G5x2 NVMe Direct Connect) + 2 x E3.S (G5x4 NVMe direct).**

Order	From	To
1	PWR1/2 (system board power connector)	BP_PWR_1 (backplane power connector)
2	SL1 (signal connector on system board)	BP_DST_PA1 (backplane signal connector)
3	SL2 (signal connector on system board)	BP_DST_PB1 (backplane signal connector)
4	SL4 (signal connector on system board)	BP_DST_PA2 (backplane signal connector)
5	SL5 (signal connector on system board)	BP_DST_PB2 (backplane signal connector)
6	SL8 (signal connector on system board)	BP_DST_PA3 (backplane signal connector)
7	SL19/SL20/PWR19/PWR20 (signal connector on system board)	R2E (Riser)
8	SL11 (signal connector on system board) and PWR11/12 (system board power connector)	R2E (Riser)

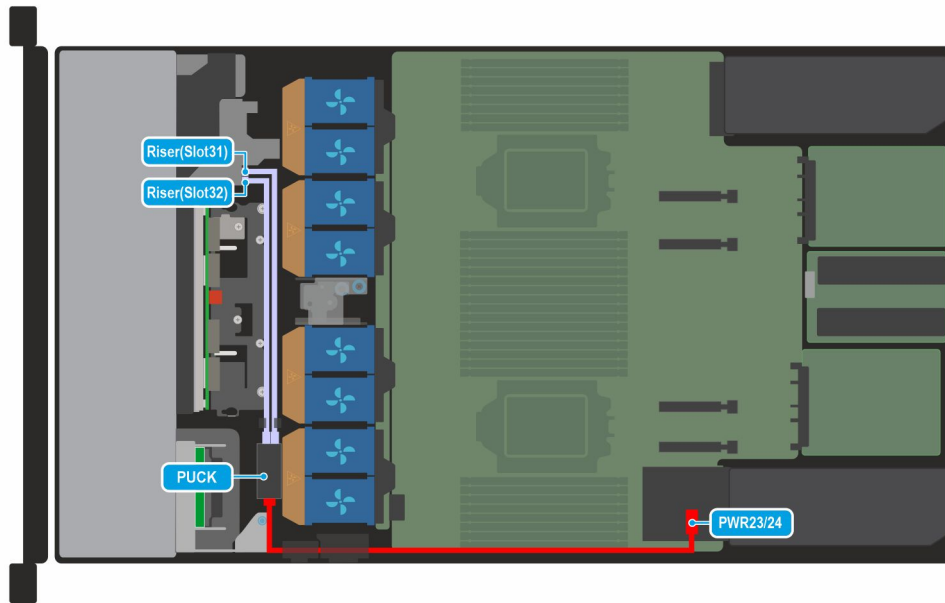

Figure 107. DPU Puck RF1a Y-cable

Table 74. DPU Puck RF1a Y-cable

Order	From	To
1	PWR23/24 (system board power connector)	Riser slot 31/32

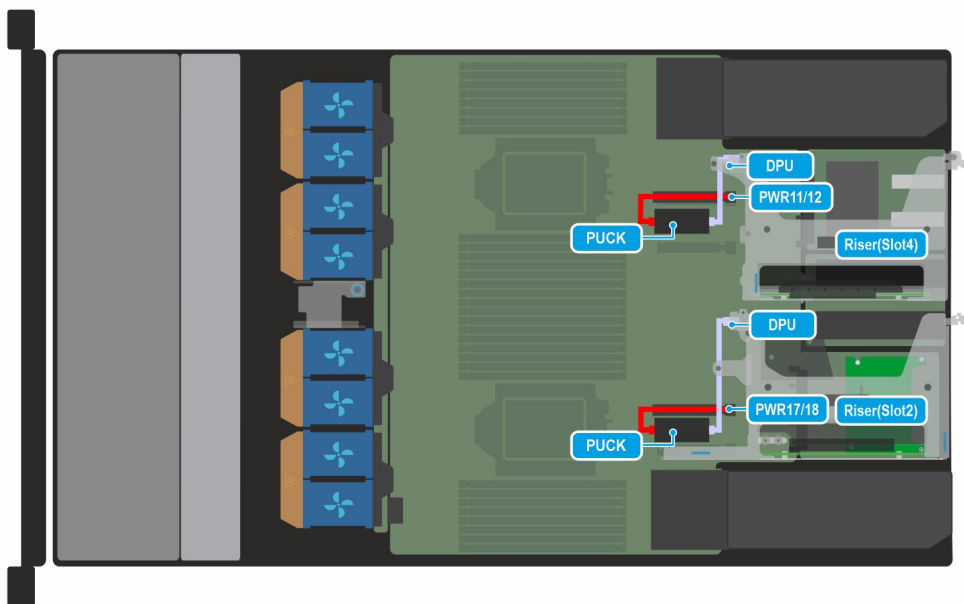

Figure 108. DPU Puck R2b+R4b

Table 75. DPU Puck R2b+R4b

Order	From	To
1	PWR17/18(system board power connector)	Riser slot 2
2	PWR11/12(system board power connector)	Riser slot 4

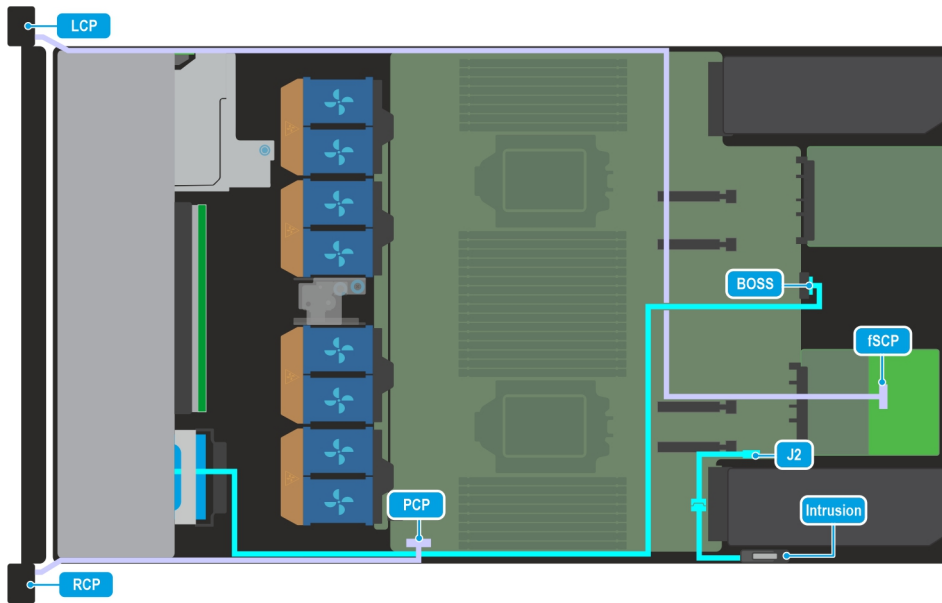

Figure 109. Additional cables

Table 76. Additional cables

Order	From	To
1	Left control panel (LCP)	fSCP (connector in Attic board)
2	PCP (signal connector on system board)	Right control panel (RCP)
3	Intrusion switch	J2 (signal connector on system board)
4	Front BOSS module	BOSS connector on system board

**NOTE:** The intrusion switch connects to the J2 connector through the additional dongle cable.

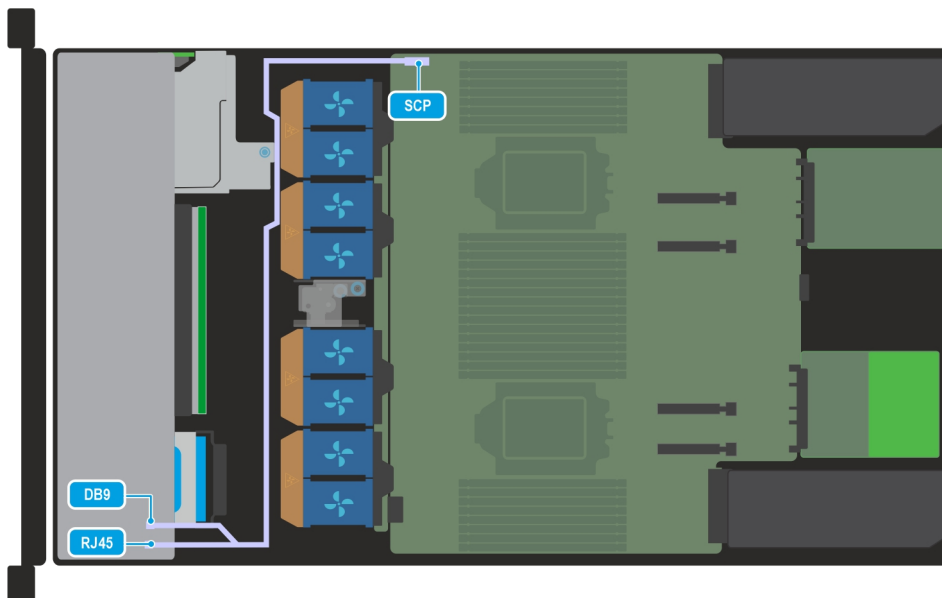

Figure 110. Front serial (DB9) and RJ45 port

**Table 77. Front serial (DB9) and RJ45 port**

Order	From	To
1	SCP (signal connector on system board)	DB9 and RJ45 connectors

## System memory

### System memory guidelines

The PowerEdge R670 system supports DDR5 registered DIMMs (RDIMMs).

Your system memory is organized into eight channels per processor (two memory sockets per channel), 16 memory sockets per processor and 32 memory sockets per system.

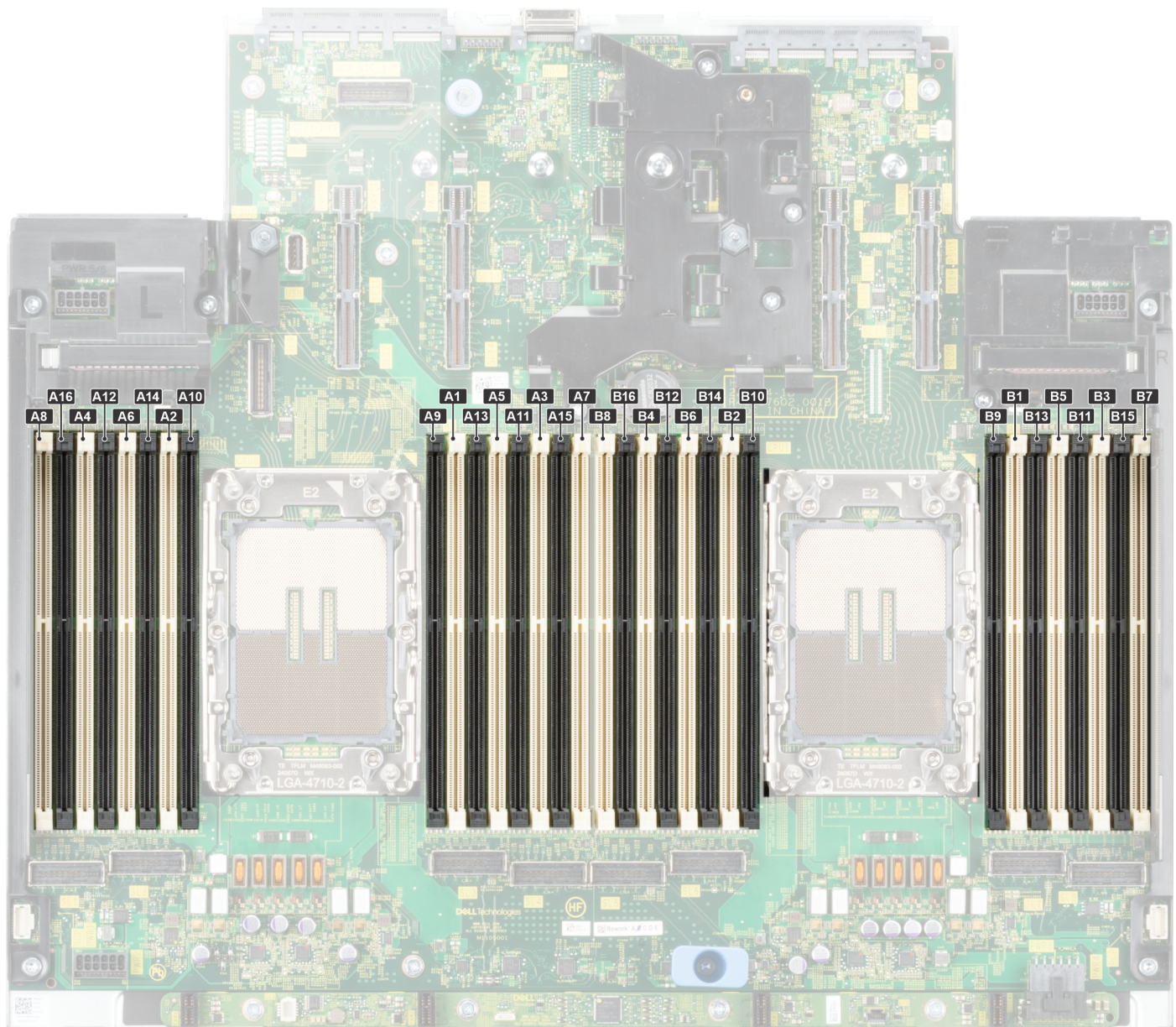

**Figure 111. Memory channels**

Memory channels are organized as follows:

**Table 78. Memory channels**

Processor	Channel A	Channel B	Channel C	Channel D	Channel E	Channel F	Channel G	Channel H
Processor 0	Slots A1 and A9	Slots A5 and A13	Slots A3 and A11	Slots A7 and A15	Slots A2 and A10	Slots A6 and A14	Slots A4 and A12	Slots A8 and A16
Processor 1	Slots B1 and B9	Slots B5 and B13	Slots B3 and B11	Slots B7 and B15	Slots B2 and B10	Slots B6 and B14	Slots B4 and B12	Slots B8 and B16

**Table 79. Supported memory matrix**

DIMM type	Rank	Capacity	DIMM rated voltage and speed	Operating Speed			
				Intel® Xeon 6 E- core processor		Intel® Xeon 6 P- core processor	
				1 DIMM per channel (DPC)	2 DIMM per channel (DPC)	1 DIMM per channel (DPC)	2 DIMM per channel (DPC)
RDIMM	1R	16 GB	DDR5 (1.1 V), 6400 MT/s	N/A	N/A	Up to 6400 MT/s	N/A
	2 R	32 GB	DDR5 (1.1 V), 6400 MT/s	Up to 6400 MT/s	N/A	Up to 6400 MT/s	Up to 5200 MT/s
		64 GB	DDR5 (1.1 V), 6400 MT/s	Up to 6400 MT/s	Up to 5200 MT/s	Up to 6400 MT/s	Up to 5200 MT/s
		96 GB	DDR5 (1.1 V), 6400 MT/s	N/A	N/A	Up to 6400 MT/s	Up to 5200 MT/s
		128 GB	DDR5 (1.1 V), 6400 MT/s	N/A	N/A	Up to 6400 MT/s	Up to 5200 MT/s
	8 R	256 GB	DDR5 (1.1 V), 6400 MT/s	N/A	N/A	N/A	Up to 5200 MT/s

**Table 80. Supported memory matrix**

DIMM Capacity	DIMMs per CPU				
	1	4	8	12	16
6700E					
32 GB	x	N/A	x	N/A	N/A
64 GB	N/A	N/A	x	N/A	x
6500/6700P					
16 GB	x	N/A	x	N/A	N/A
32 GB	x	x	x	x	x
64 GB	N/A	x	x	N/A	x
128 GB	N/A	N/A	x	N/A	x
256 GB	N/A	N/A	N/A	N/A	x

**NOTE:**

- DIMMs with capacities 32 GB, and 64 GB are supported on E- core processors.

- DIMMs with capacities 16 GB, 32 GB, 64 GB, 96 GB, 128 GB, and 256 GB are supported on P- core processors.

**NOTE:** The processor may reduce the performance of the rated DIMM speed.

## General memory module installation guidelines

To ensure optimal performance of your system, observe the following general guidelines when configuring your system memory. If your system's memory configuration fails to observe these guidelines, your system might not boot, stop responding during memory configuration, or operate with reduced memory.

The memory bus may operate at speeds of 6400 MT/s or lower speed depending on the following factors:

- System profile selected (for example, Performance, Performance Per Watt Optimized (OS), or Custom [can be run at high speed or lower])
- Maximum supported DIMM speed of the processors
- Only DDR5- 6400 MT/s RDIMMs are supported

**NOTE:** MT/s indicates DIMM speed in Mega-Transfers per second.

**NOTE:** Fault Resilient Memory and memory mirroring are not supported.

The following are the recommended guidelines for installing memory modules:

- All DIMMs must be DDR5.
- DIMM mixing configurations are not supported. All DIMM slots must be populated with the exact same DIMMs.
- Populate memory module sockets only if a processor is installed.
  - For dual-processor systems, sockets A1 to A16 and sockets B1 to B16 are available.
- In **Optimizer Mode**, the DRAM controllers operate independently in the 64-bit mode and provide optimized memory performance.

**Table 81. Memory population rules**

Processor	Memory population	Memory population information
Dual processor	A{1}, B{1}, A{2}, B{2}, A{3},B{3}, A{4}, B{4}, A{5}, B{5},A{6}, B{6}, A{7}, B{7}, A{8},B{8}, A{9}, B{9}, A{10},B{10}, A{11}, B{11}, A{12}, B{12}, A{13}, B{13}, A{14},B{14}, A{15}, B{15}, A{16},B{16}	2, 16 or 32 DIMMs are supported per system.

- Populate all the sockets with white release tabs first, followed by the sockets with black release tabs.
- Unbalanced or odd memory configurations result in a performance loss, and the system may not identify the memory modules being installed. Always populate memory channels identically with equal DIMMs for the best performance.
- Supported RDIMM configurations are 1, 8 or 16 DIMMs per processor, only 32 GB is allowed for 1DIMM per processor.
- Populate eight or sixteen identical memory modules per processor at a time to maximize performance.

## Removing a memory module

### Prerequisites

1. Follow the safety guidelines listed in the [Safety instructions](#).
2. Follow the procedure listed in [Before working inside your system](#).

**WARNING:** The memory modules are hot to touch for some time after the system has been powered off. Allow the memory modules to cool before handling them.

**NOTE:** For proper system cooling, memory module blanks must be installed in any memory socket that is not populated. Remove the memory module blanks only if you intend to install the memory module in these sockets. DIMM blanks are only required when CPU TDP is equal or greater than 225W. CPU with TDP less that 225W do not require DIMM blanks.

### Steps

1. Locate the appropriate memory module socket.

2. To release the memory module from the socket, simultaneously press the ejectors on both ends of the memory module socket to fully open.

**CAUTION:** Handle each memory module only by the card edges, ensuring not to touch the middle of the memory module or metallic contacts.

3. Lift the memory module away from the system.

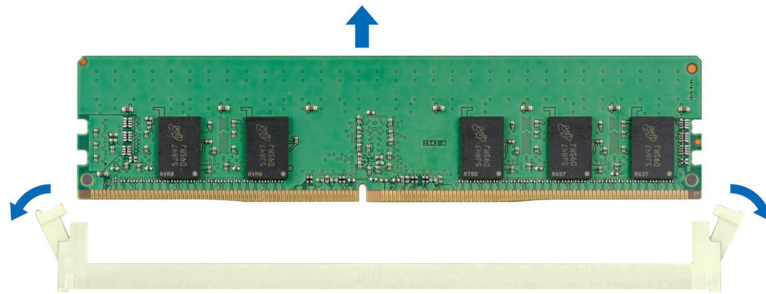

Figure 112. Removing a memory module

### Next steps

Replace the memory module.

## Installing a memory module

### Prerequisites

1. Follow the safety guidelines listed in the [Safety instructions](#).
2. Follow the procedure listed in [Before working inside your system](#).

### Steps

1. Locate the appropriate memory module socket.

**CAUTION:** Handle each memory module only by the card edges, ensuring not to touch the middle of the memory module or metallic contacts.

**NOTE:** Ensure that the socket ejector latches are fully open before installing the memory module.

2. Align the edge connector of the memory module with the alignment key of the memory module socket, and insert the memory module in the socket.

**CAUTION:** To prevent damage to the memory module or the memory module socket during installation, do not bend or flex the memory module. Insert both ends of the memory module simultaneously.

**NOTE:** The memory module socket has an alignment key that enables you to install the memory module in the socket in only one orientation.

**CAUTION:** Do not apply pressure at the center of the memory module; apply pressure at both ends of the memory module evenly.

3. Press the memory module with your thumbs until the ejectors firmly click into place. When the memory module is properly seated in the socket, the memory module socket levers align with the levers on the other sockets that have memory modules that are installed.

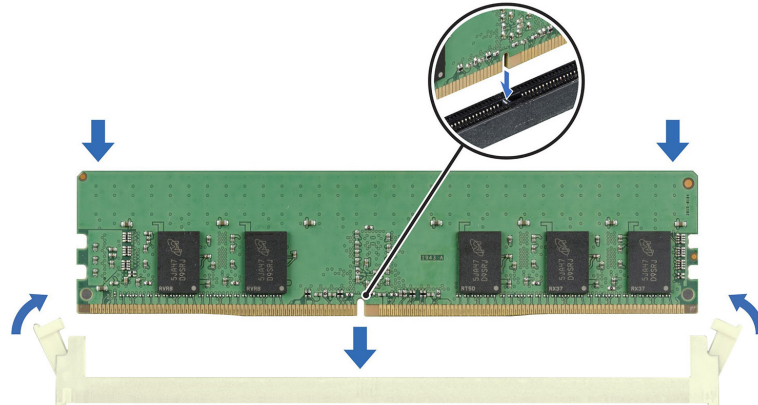

**Figure 113. Installing a memory module**

#### Next steps

1. Follow the procedure listed in [After working inside your system](#).
2. To verify that the memory module has been installed properly, press **F2** during reboot and click **System Setup Main Menu > System BIOS > Memory Settings**. In the **Memory Settings** screen, the **System Memory Size** must reflect the updated capacity of the installed memory.
3. If the **System Memory Size** is incorrect, one or more of the memory modules may not be installed properly. Shut down the system and ensure that the memory modules are firmly seated in the correct sockets.
4. Run the system memory test in system diagnostics.

## Processor and heat sink

This is a service technician replaceable part only.

## Removing the processor and heat sink module

#### Prerequisites

1. Follow the safety guidelines listed in the [Safety instructions](#).
2. Follow the procedure listed in the [Before working inside your system](#).

**NOTE:** The heat sink and processor are hot to touch for some time after the system has been powered off. Allow the heat sink and processor to cool down before handling them.

3. The system supports different to types of heatsinks and the procedure to remove them are similar.

**NOTE:** The heat sink and processor are hot to touch for some time after the system has been powered off. Allow the heat sink and processor to cool down before handling them.

#### Steps

1. Ensure all four anti-tilt wires are in the locked position (outward position), and then using a Torx T30 screwdriver, loosen the captive nuts on the processor heat sink module (PHM) in the order that is mentioned below:

- a. Loosen the first nut three turns.
- b. Loosen the nut diagonally opposite to the nut you loosened first.
- c. Repeat the procedure for the remaining two nuts.
- d. Return to the first nut and loosen it completely.

**i** **NOTE:** Ensure that the anti-tilt wires on the PHM are in locked position when loosening the captive nuts.

2. Set all the anti-tilt wires to unlocked position (inward position).

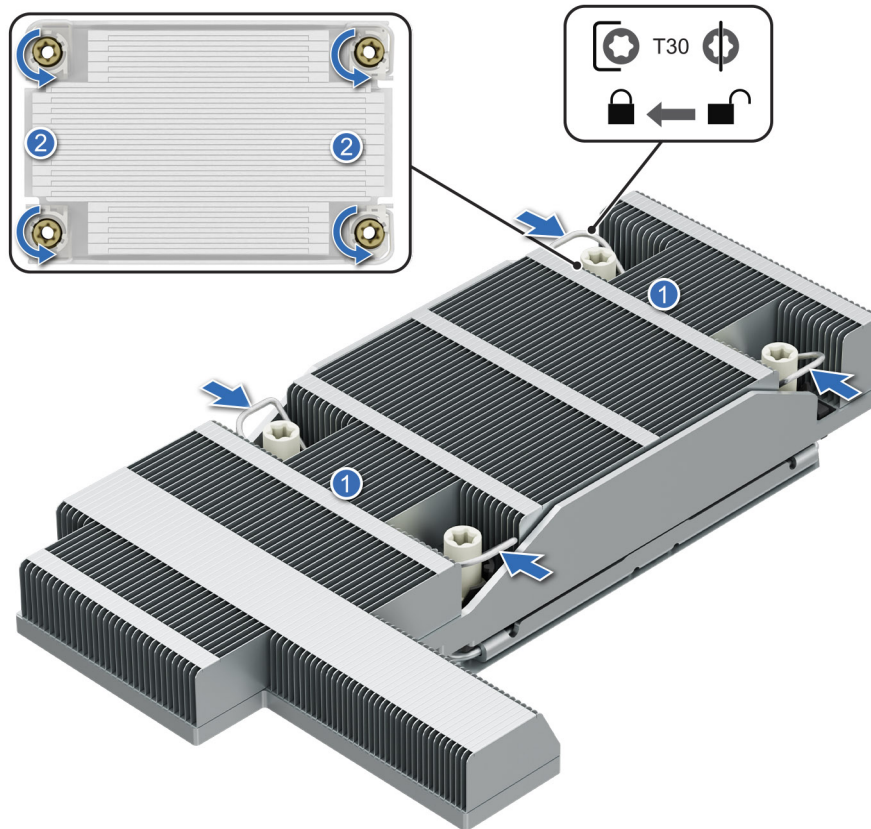

**Figure 114. Removing the processor heat sink module**

3. Lift the PHM from the system and set the PHM aside with the processor side facing up.

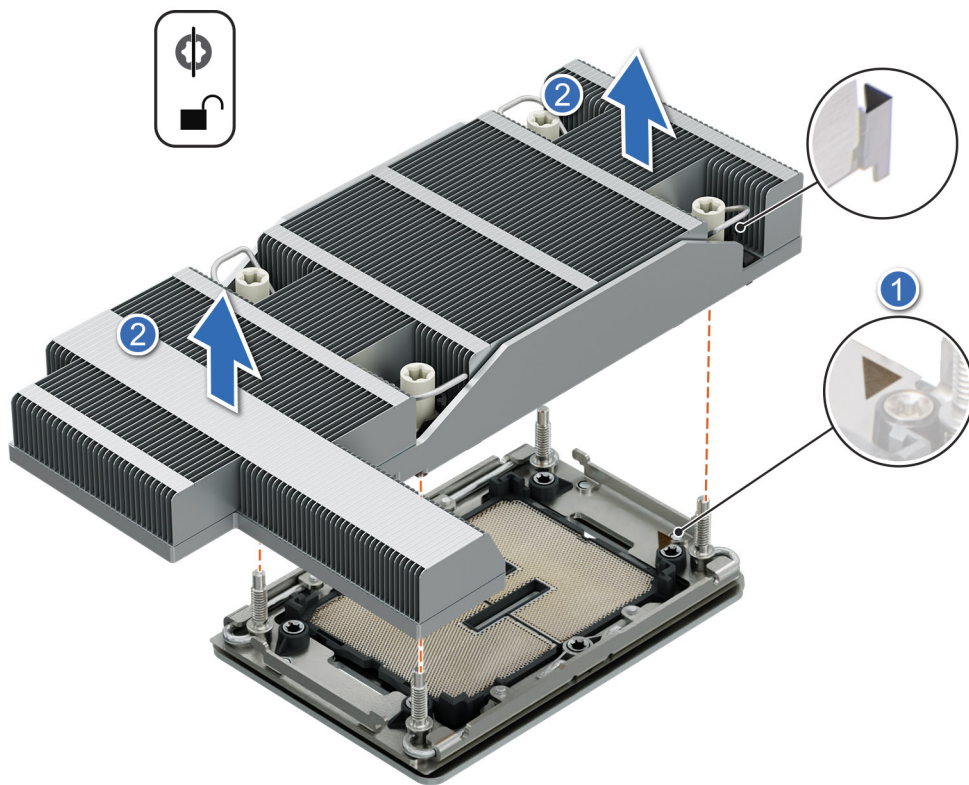

Figure 115. Removing a heat sink

### Next steps

If you are removing a faulty heat sink, [replace the heat sink](#), if not, [remove the processor](#).

## Removing the processor

### Prerequisites

**⚠ WARNING:** Remove the processor from processor and heat sink module (PHM) only if you are replacing the processor or heat sink.

1. Follow the safety guidelines listed in the [Safety instructions](#).
2. Follow the procedure listed in the [Before working inside your system](#).
3. [Remove the processor heat sink module](#).

**⚠ CAUTION:** You may find the CMOS battery loss or CMOS checksum error that is displayed during the first instance of powering on the system after the processor or system board replacement which is expected. To fix this, go to setup option to configure the system settings.

### Steps

1. Place the heat sink with the processor side facing up.
2. Using your thumb, lift the thermal interface material (TIM) break lever to release the processor from the TIM and retaining clip.
3. Holding the processor by the edge, lift the processor away from the retaining clip.

**i NOTE:** Ensure to hold the retaining clip to the heat sink as you lift the TIM break lever.

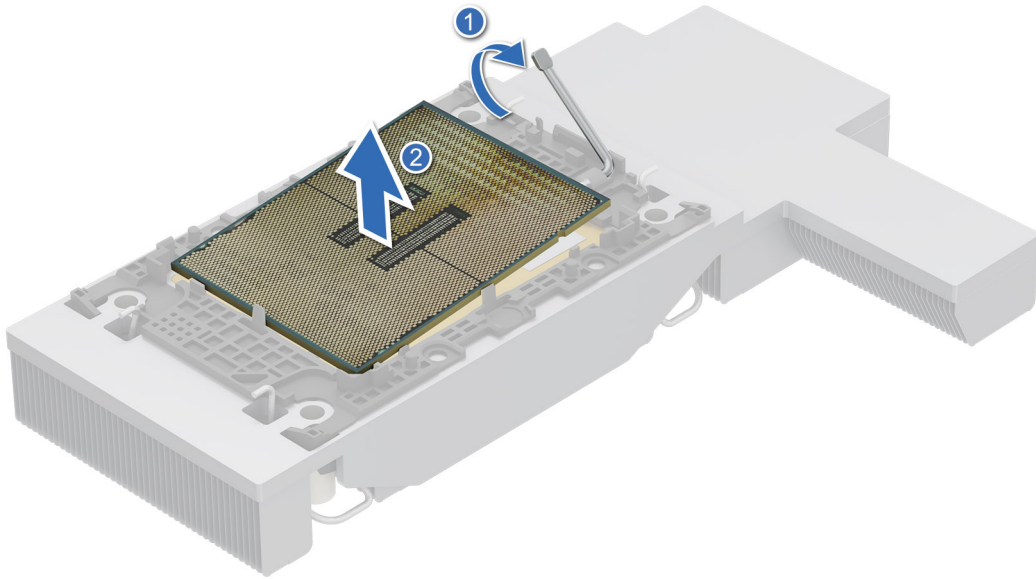

**Figure 116. Removing the processor**

**NOTE:** Ensure to return the TIM break lever on the retaining clip back to its original position.

4. Using your thumb and index finger, first hold the retaining clip release tab at the pin 1 connector, pull out the tip of the retaining clip release tab, and then lift the retaining clip partially from the heat sink.
5. Repeat the procedure at the remaining three corners of the retaining clip.
6. After all the corners are released from the heat sink, lift the retaining clip from the pin 1 corner of the heat sink.

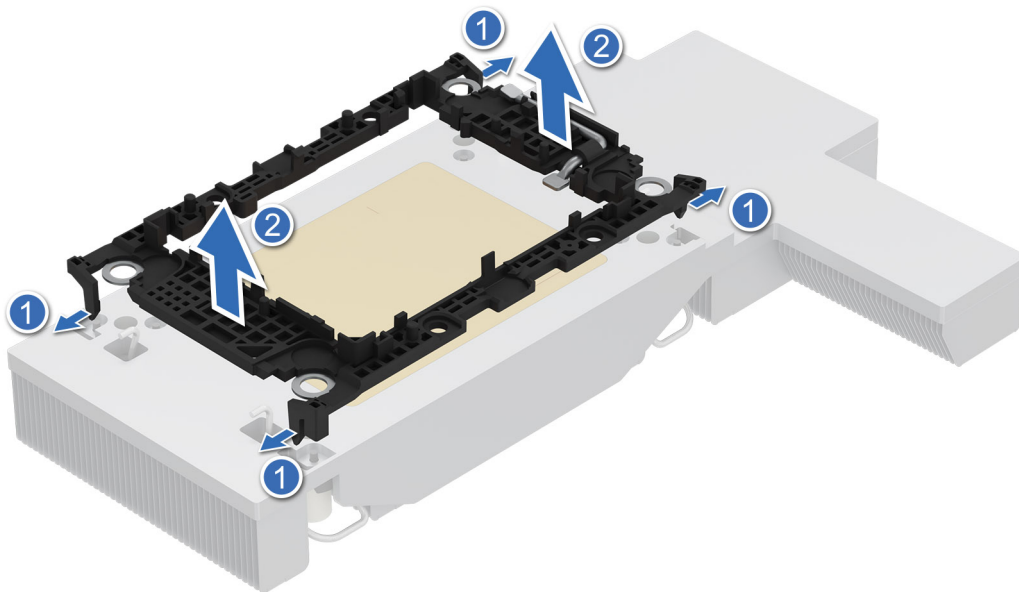

**Figure 117. Removing the retaining clip**

#### **Next steps**

Replace the processor.

# Installing the processor

## Prerequisites

1. Follow the safety guidelines listed in the [Safety instructions](#).
2. Follow the procedure listed in the [Before working inside your system](#).
3. [Remove the processor heat sink module](#).

## Steps

1. Place the processor in the processor tray.

**i** **NOTE:** Ensure the pin 1 indicator on the processor tray is aligned with the pin 1 indicator on the processor.

2. Place the retaining clip on top of the processor in the processor tray, aligning pin 1 indicator on the processor.

**i** **NOTE:** Ensure the pin 1 indicator on the retaining clip is aligned with the pin 1 indicator on the processor before placing the retaining clip on the processor.

**i** **NOTE:** Before you install the heat sink, ensure to place the processor and retaining clip in the tray.

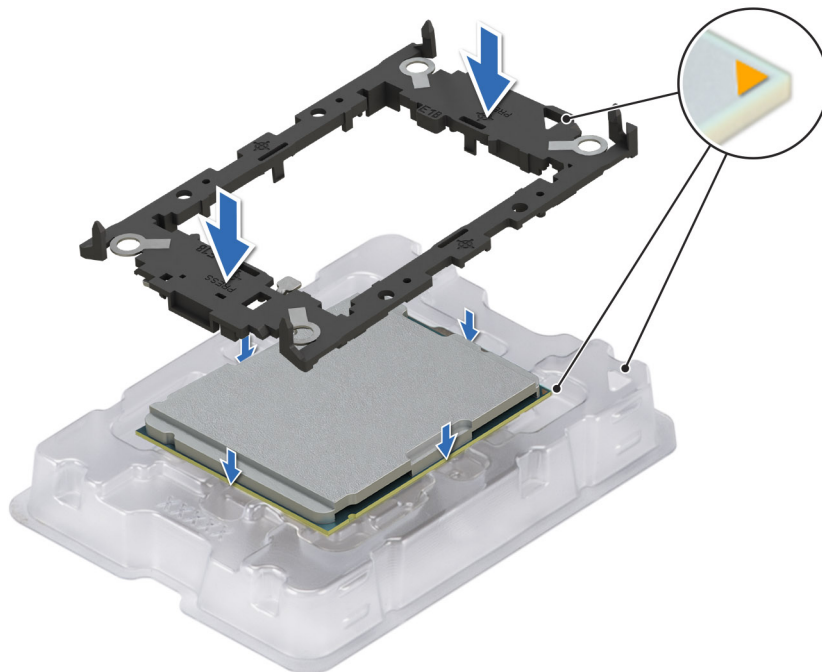

**Figure 118. Installing the retaining clip**

3. Align the processor with a retaining clip, by using your fingers press the retaining clip on all the four sides until it clicks into place.

**i** **NOTE:** Ensure that the processor is securely latched to the retaining clip.

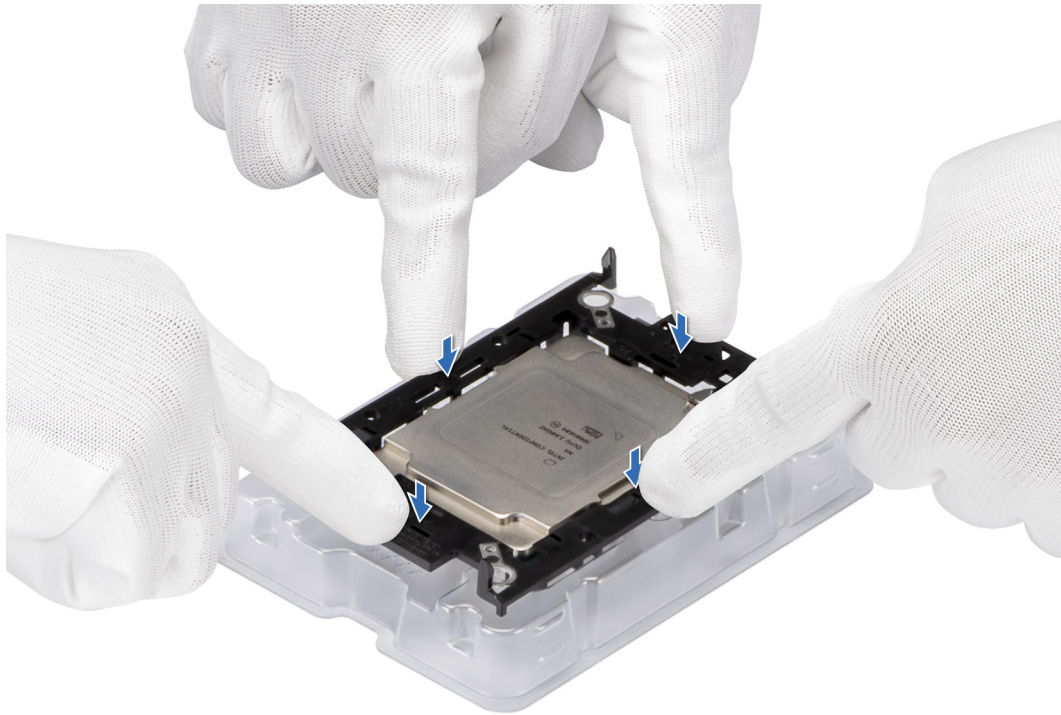
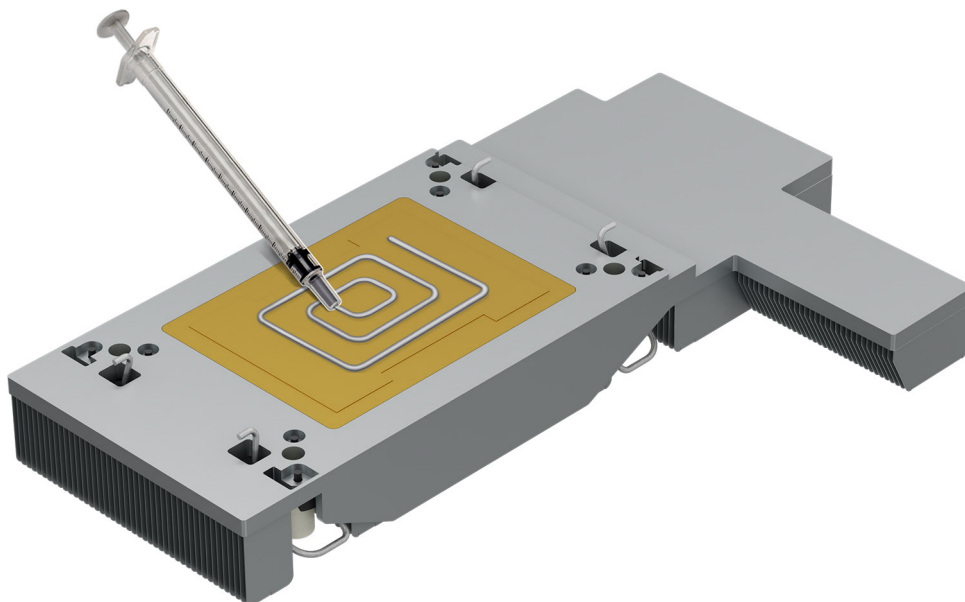

**Figure 119. Press the retaining clip on the four sides**

4. If you are using an existing heat sink, remove the thermal grease from the heat sink by using a clean lint-free cloth.
5. Apply the thermal grease in a thin spiral design on the bottom of the heat sink.

**CAUTION:** Applying too much thermal grease can result in excess grease coming in contact with and contaminating the processor socket.

**NOTE:** The thermal grease syringe is intended for single use only. Dispose the syringe after you use it.



**Figure 120. Applying thermal grease**

6. For a new heat sink, pull and remove the plastic cover from the base of the heat sink.

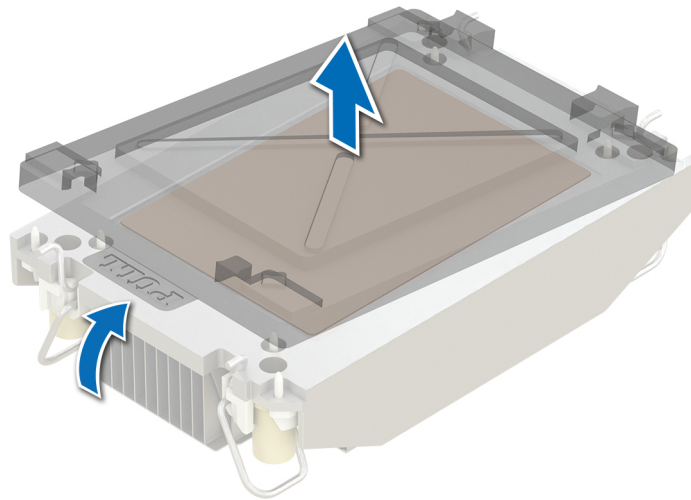

**Figure 121. Removing the cover**

7. Place the heat sink on the processor and press the base of the heat sink until the retaining clip locks onto the heat sink at all the four corners.

**CAUTION:** To avoid damaging the fins on the heat sink, do not press down on the heat sink fins.

**NOTE:**

- Ensure latching features on retaining clip, and heat sink are aligned during assembly.
- Ensure that the pin 1 indicator on the heat sink is aligned with the pin 1 indicator on the retaining clip before placing the heat sink onto the retaining clip.

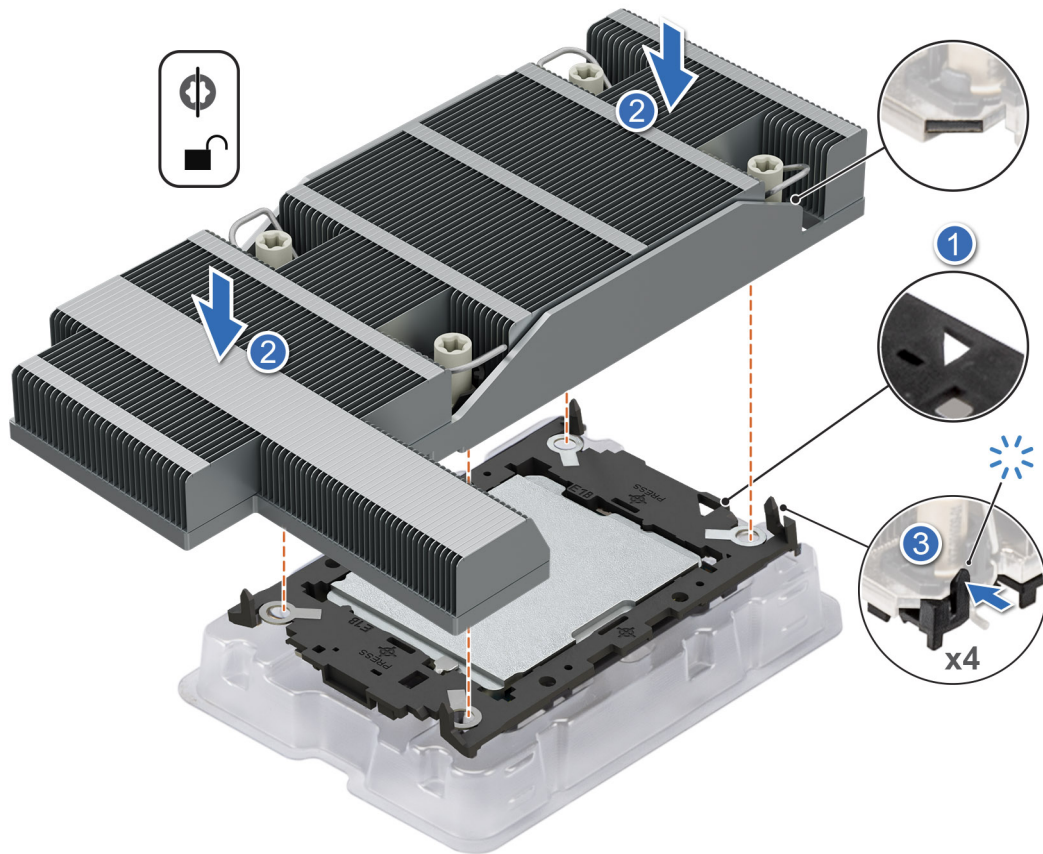

Figure 122. Installing the heat sink onto the processor

### Next steps

1. [Install the processor heat sink module.](#)
2. Follow the procedure listed in [After working inside your system.](#)

## Installing the processor and heat sink module

### Prerequisites

Never remove the heat sink from a processor unless you intend to replace the processor or heat sink. The heat sink is necessary to maintain proper thermal conditions.

1. Follow the safety guidelines listed in the [Safety instructions.](#)
2. Follow the procedure listed in the [Before working inside your system.](#)
3. If installed, remove the processor dust cover.
4. The system supports different to types of heatsinks and the procedure to install them are similar.

### Steps

1. Set the anti-tilt wires to the unlocked position on the heat sink (inward position).
2. Align the pin 1 indicator of the heat sink to the system board, and then place the processor heat sink module (PHM) on the processor socket.

**CAUTION:** To avoid damaging the fins on the heat sink, do not press down on the heat sink fins.

**NOTE:** Ensure that the PHM is held parallel to the system board to prevent damaging the components.

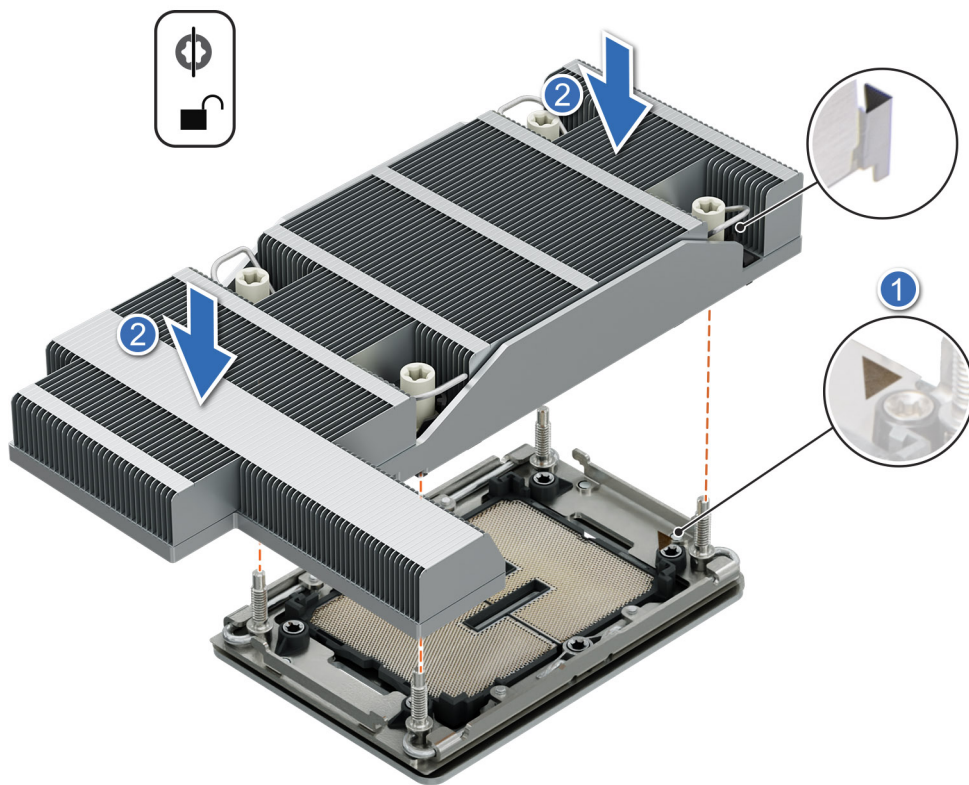

**Figure 123. Installing the processor heat sink**

3. Set the anti-tilt wires to the locked position (outward position), and then using the Torx T30 screwdriver, tighten the captive nuts (8 in-lbf) on the heat sink in the order below:
  - a. In a random order, tighten the first nut three turns.
  - b. Tighten the nut diagonally opposite to the nut that you tighten first.
  - c. Repeat the procedure for the remaining two nuts.
  - d. Return to the first nut to tighten it completely.
  - e. Check all the nuts to ensure they are firmly secured.

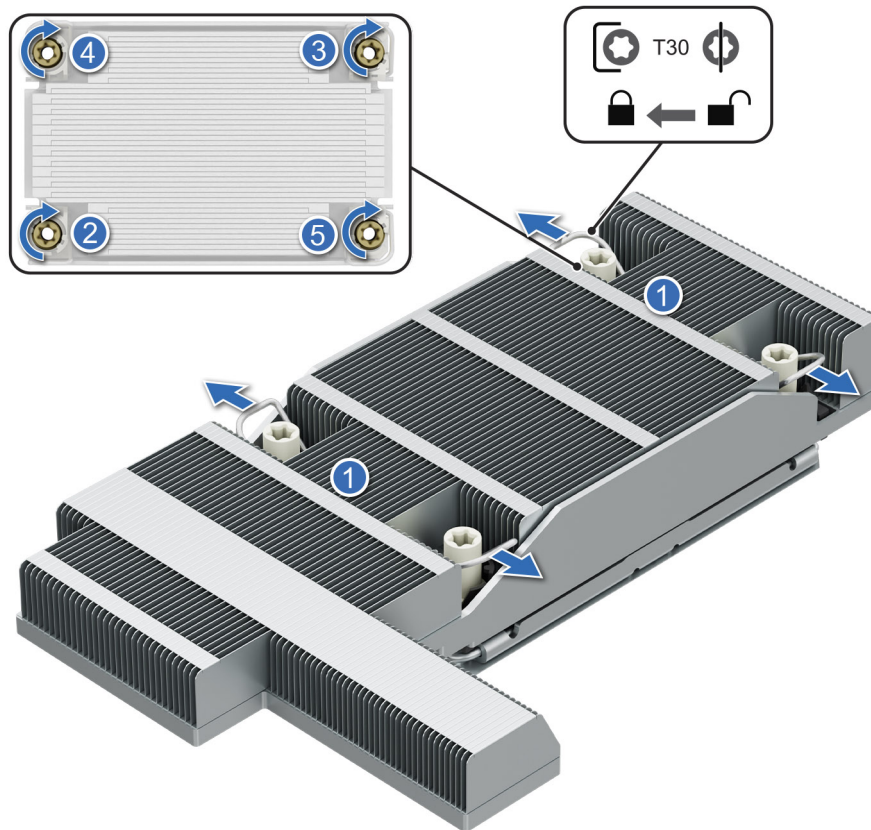

**Figure 124. Set the anti-tilt wires to the locked position and tightening the nuts**

### Next steps

1. Follow the procedure listed in the [After working inside your system](#).

## Removing the Direct Liquid Cooling module

### Steps

1. Loosen the screw on the DLC bracket using a Philips 1 screw driver.
2. Pull the bracket outward from its location.
3. Loosen the captive screw.
4. Remove the DLC tubes from the DLC bracket..
5. Disconnect the DLC leak detection cable from the HPM .
6. Slightly lift the DLC tubes surrounding the DIMM slots.
7. Ensure all four anti-tilt wires are in the locked position (outward position), and then using a Torx T30 screwdriver, loosen the captive nuts on the DLC module in the order that is mentioned below:
  - a. Loosen the first nut three turns.
  - b. Loosen the nut diagonally opposite to the nut you loosened first.
  - c. Repeat the procedure for the remaining two nuts.
  - d. Return to the first nut and loosen it completely.

**NOTE:** Ensure that the anti-tilt wires on the DLC module are in locked position when loosening the captive nuts.

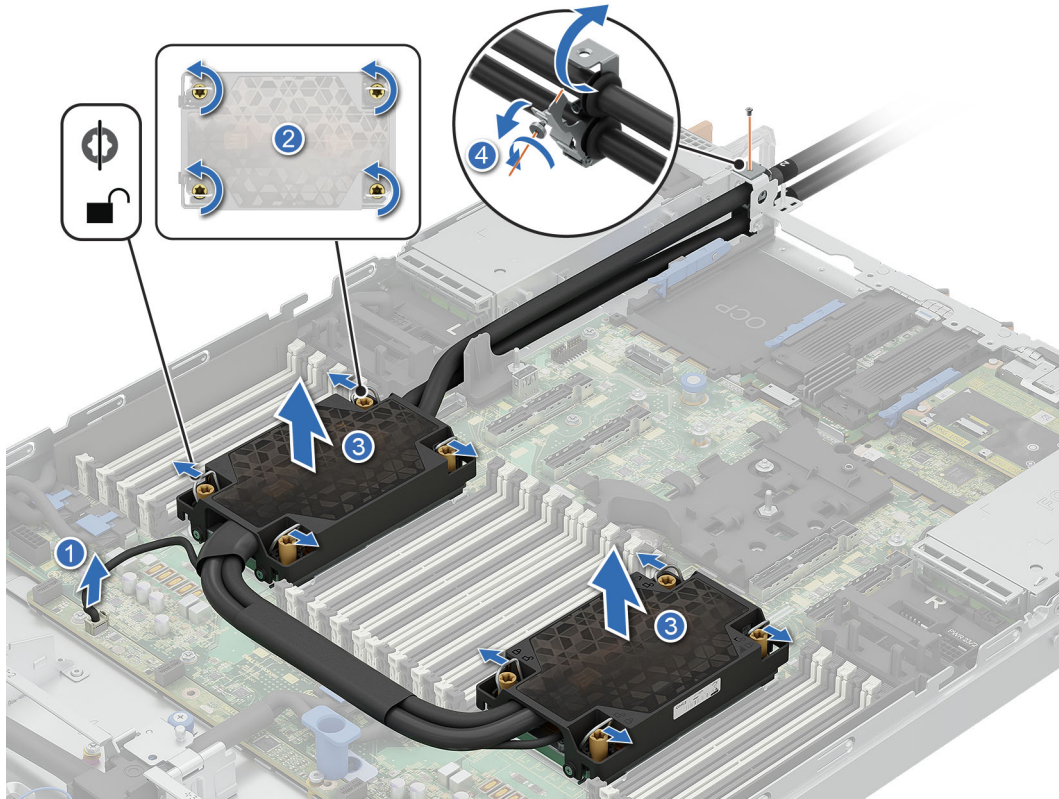

**Figure 125. Removing the DLC module**

- Set the anti-tilt wires on the DLC module to the unlock position and lift the DLC module from the system.

**NOTE:** The numbers on the image do not depict the exact steps. The numbers are for representation of sequence.

#### Next steps

- If you are removing a faulty liquid cooling module, [replace the Direct Liquid Cooling module](#), else [remove the processor](#).

## Installing the Direct Liquid Cooling module

#### Prerequisites

Never uninstall the Direct Liquid Cooling (DLC) module from a processor unless you intend to replace the processor or system board. The DLC module is necessary to maintain proper thermal conditions.

- Follow the safety guidelines listed in the [Safety instructions](#).
- Follow the procedure listed in the [Before working inside your system](#).
- [Remove the air shroud](#).
- [Remove the expansion card riser](#).
- If installed, remove the processor dust cover.

**NOTE:** Ensure anti-tilt wires on the DLC module are in the unlocked position.

#### Steps

- Align the DLC module with the standoff screws on the system board.
- Place the module on the processor slot and set all the anti-tilt wires to locked position (outward position).
- Using the Torx T30 screwdriver, tighten the captive nuts (8 in-lbf) on the DLC module in the order below:
  - In a random order, tighten the first nut three turns.
  - Tighten the nut diagonally opposite to the nut that you tighten first.

- c. Repeat the procedure for the remaining two nuts.
- d. Return to the first nut to tighten it completely.
- e. Check all the nuts to ensure they are firmly secured.
4. Make sure the tube is placed on the holder and goes through the rear wall hole.
5. Install the rear end of the DLC tubes through the DLC bracket.
  - a. Open DLC bracket.
  - b. Fix the tube grommets in the DLC bracket.
  - c. Make sure the tubes and DLC bracket numbers are aligned.
  - d. Fasten the captive screw.
  - e. Push the bracket inward to the correct location.
  - f. Fasten the screw on the DLC bracket using a Philips 1 screw driver.

**NOTE:** Follow the number labels on the DLC tubes and ring holders (1,2).

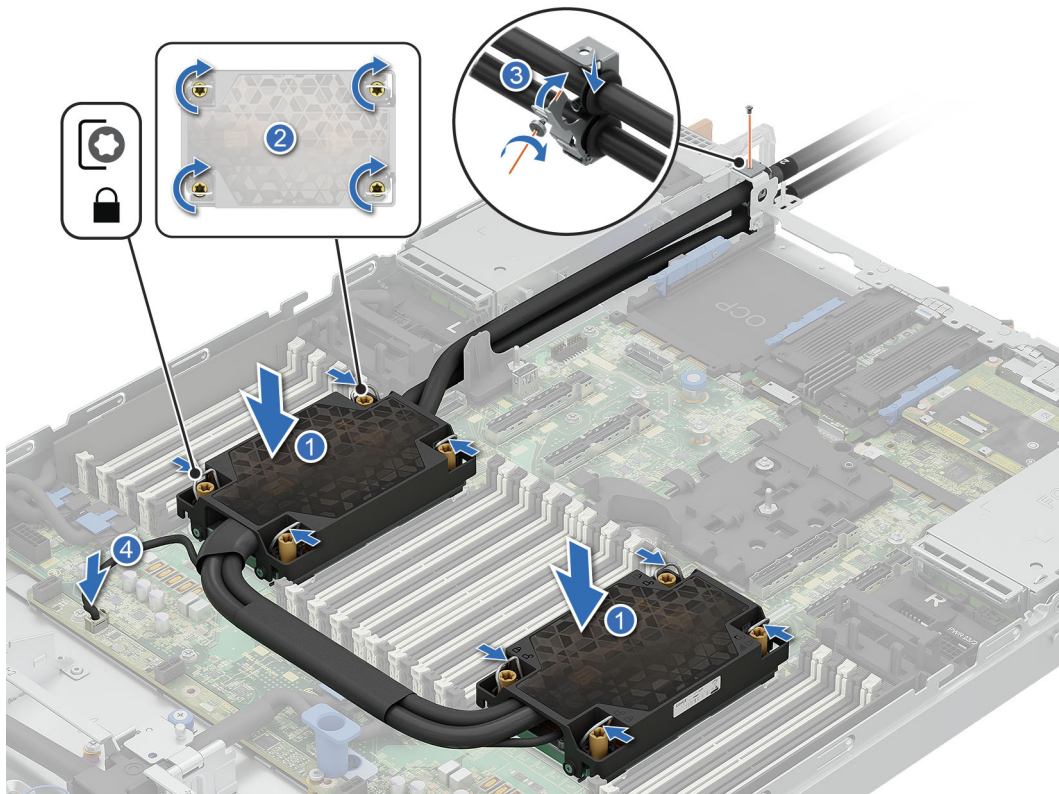

**Figure 126. Installing the DLC module**

6. Connect the DLC leak detection cable to the connector on HPM.

**NOTE:** The numbers on the image do not depict the exact steps. The numbers are for representation of sequence.

#### Next steps

1. [Install the expansion card riser.](#)
2. [Install the air shroud.](#)
3. Follow the procedure listed in the [After working inside your system.](#)

## Expansion cards and expansion card risers

**NOTE:** When an expansion card is not supported or missing, the iDRAC logs an event. This does not prevent your system from booting. However, if a F1/F2 pause occurs with an error message, see [EEMI guide](#).

# Expansion card installation guidelines

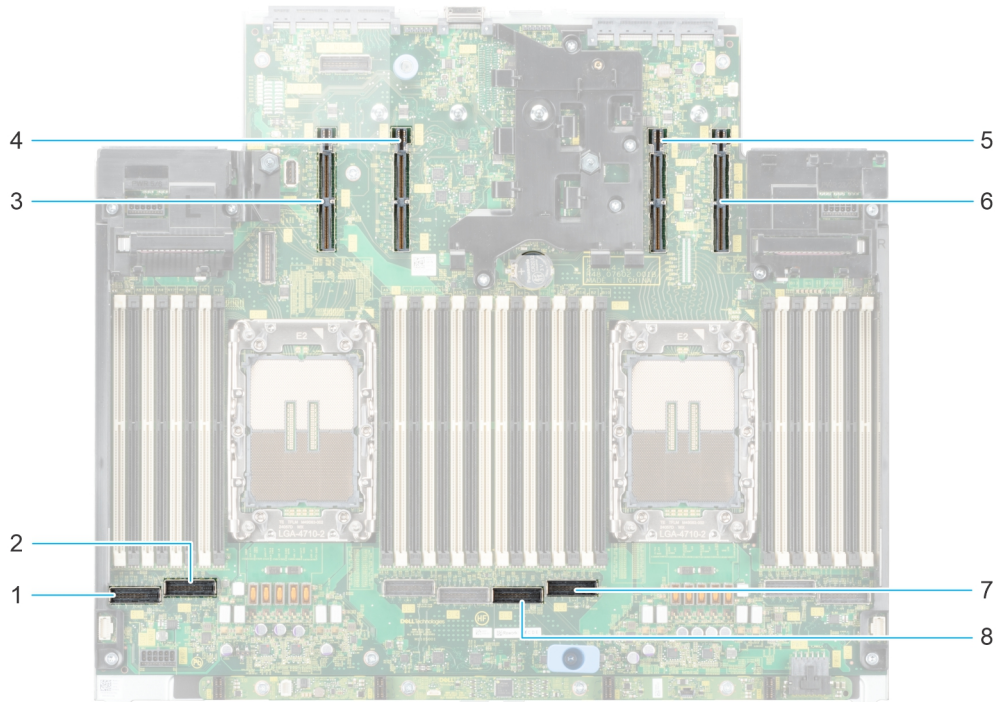

**Figure 127. Expansion card riser slot connectors**

- 1. Front riser SL connector (RF1a/ RF1b)
- 2. Front riser SL connector (RF1a/ RF1b)
- 3. Riser R5 slot
- 4. Riser 4 slot (R4a, R4b)
- 5. Riser 2 slot (R2f slot 2)
- 6. Riser 1 slot (R2f slot 1, R2b)
- 7. Front riser SL connector (RF1a/ RF1b)
- 8. Front riser SL connector (RF1a/ RF1b)

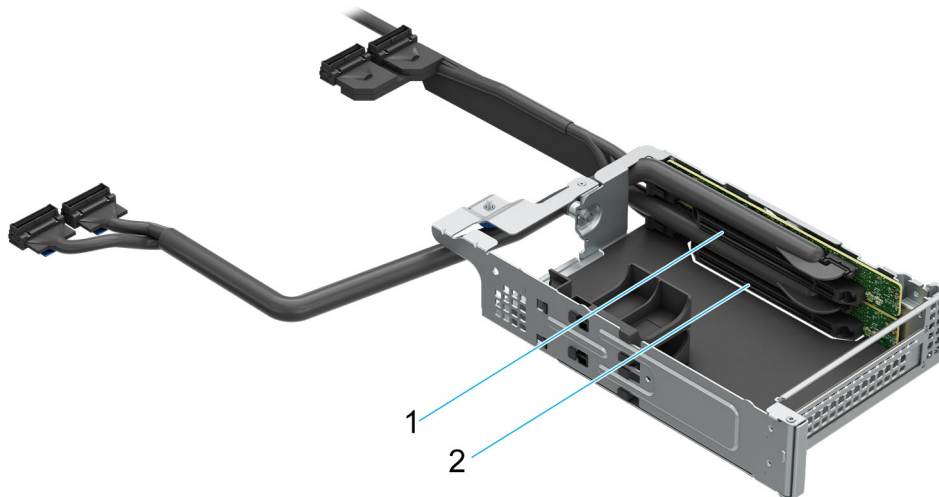

**Figure 128. Front Riser 1a (RF1a)**

- 1. Slot 31
- 2. Slot 32

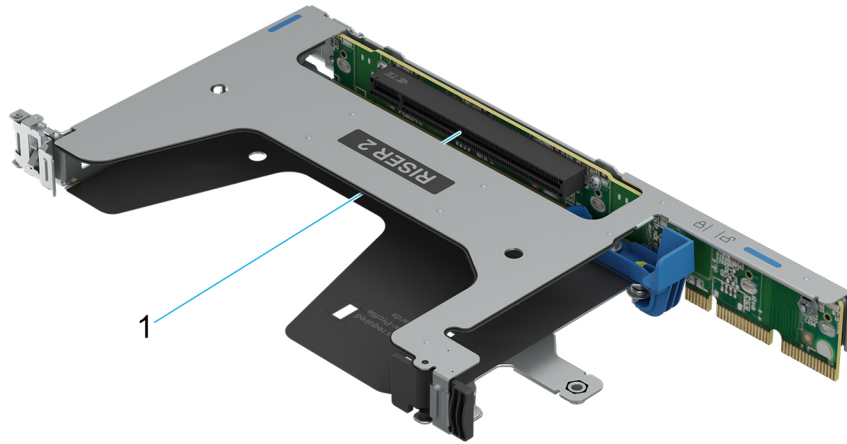

**Figure 129. Riser 2 (R2b)**

1. Slot 1

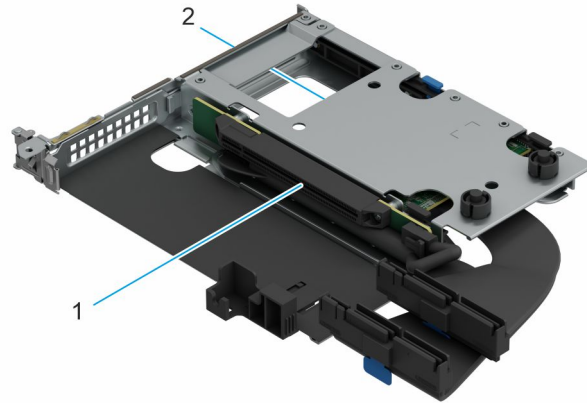

**Figure 130. Riser 2 (R2f)**

1. Slot 1
2. Slot 2

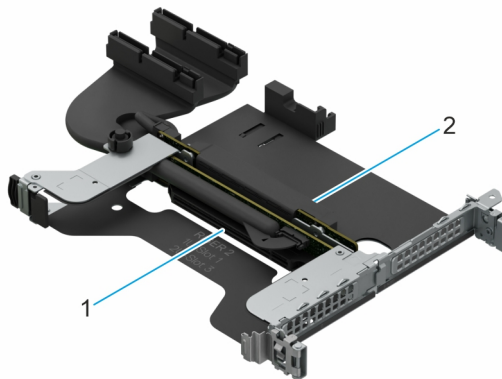

**Figure 131. Riser 2 (R2c)**

1. Slot 2
2. Slot 1

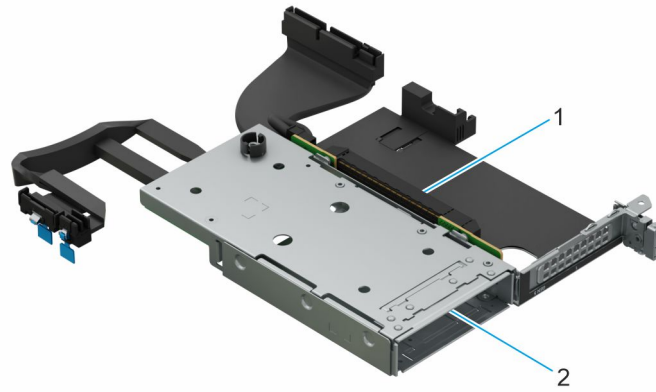

**Figure 132. Riser 2 (R2e)**

- 1. Slot 1
- 2. 2x E3 NVMe rear drive

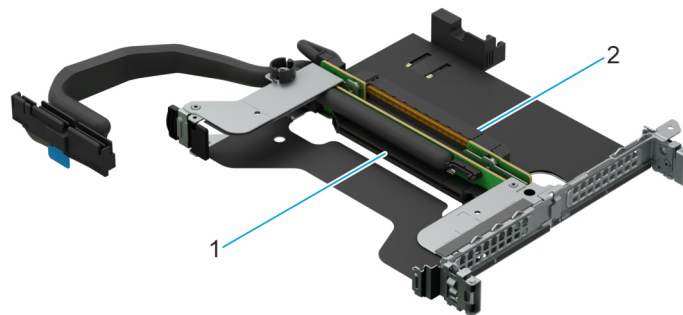

**Figure 133. Riser 2 (R2g)**

- 1. Slot 2
- 2. Slot 1

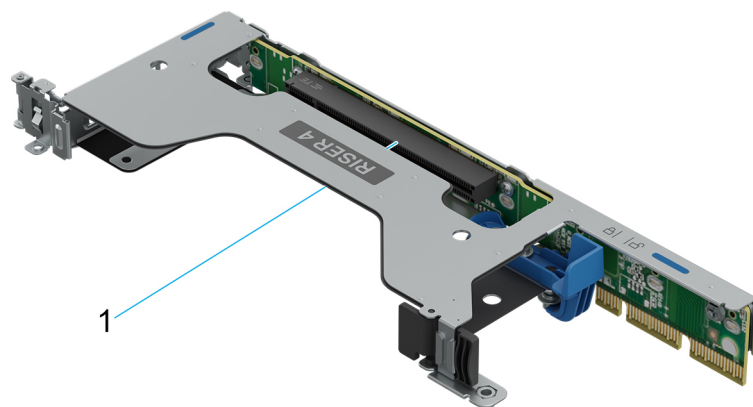

**Figure 134. Riser 4 (R4a)**

- 1. Slot 4

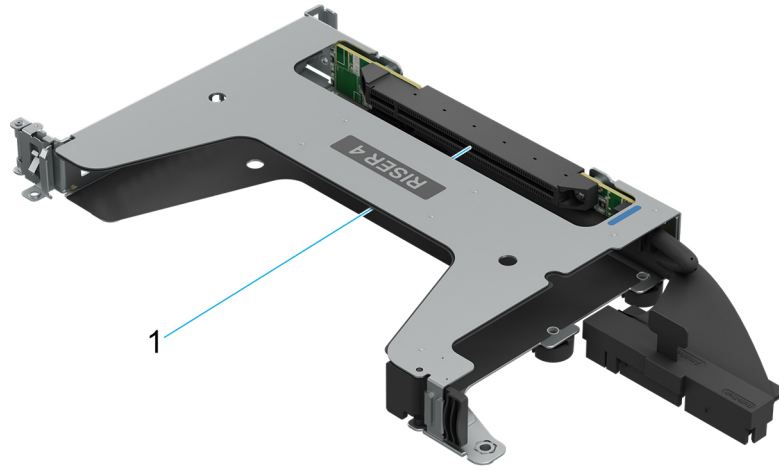

**Figure 135. Riser 4 (R4b)**

1. Slot 4

**NOTE:** The expansion-card slots are not hot-swappable.

The following table provides guidelines for installing expansion cards to ensure proper cooling and mechanical fit. The expansion cards with the highest priority should be installed first using the slot priority indicated. All the other expansion cards should be installed in the card priority and slot priority order.

**Table 82. Expansion card riser configurations**

Riser Configurations (RC)	Expansion card risers	PCIe Slots	Form factor	Controlling processor	Slot's electrical bandwidth/ physical connector
RC0: 1 x8/x16 OCP(G5)+1xBOSS	OCP	5	OCP	Processor 0	PCIe Gen5 x16 (OCP 4C+ connector)
	BOSS	3	BOSS	Processor 0	PCIe Gen3 x4 (1C connector)
RC 1 (front): 2x16FH(G5)	RF1a	31	Full height	Processor 0	PCIe Gen5 x16 (x16 connector)
		32	Full height	Processor 1	PCIe Gen5 x16 (x16 connector)
	BOSS	34	BOSS	Processor 0	PCIe Gen3 x4 (1C connector)
RC 2 (front): 2x16OCP(G5)	RF1b	31	OCP	Processor 0	PCIe Gen5 x16 (OCP 4C+ connector)
		32	OCP	Processor 1	PCIe Gen5 x16 (OCP 4C+ connector)
	BOSS	34	BOSS	Processor 0	PCIe Gen3 x4 (1C connector)
RC 5 (rear): 2x16FH(G5) +1 x8/x16 OCP(G5)	R2b	1	Full height	Processor 1	PCIe Gen5 x16 (x16 connector)
	R4b	4	Full height	Processor 0	PCIe Gen5 x16 (x16 connector)

**Table 82. Expansion card riser configurations (continued)**

Riser Configurations (RC)	Expansion card risers	PCIe Slots	Form factor	Controlling processor	Slot's electrical bandwidth/ physical connector
	BOSS	3	BOSS	Processor 0	PCIe Gen3 x4 (1C connector)
	OCP	5	OCP	Processor 0	PCIe Gen5 x16 (OCP 4C+ connector)
RC 6 (rear): 2x16LP(G5) + 1x16OCP(G5) + 1 x8/x16 OCP(G5)	R2f	1	Low Profile	Processor 1	PCIe Gen5 x16 (x16 connector)
		2	OCP	Processor 1	PCIe Gen5 x16 (OCP 4C+ connector)
	R4a	4	Low Profile	Processor 0	PCIe Gen5 x16 (x16 connector)
	BOSS	3	BOSS	Processor 0	PCIe Gen3 x4 (1C connector)
	OCP	5	OCP	Processor 0	PCIe Gen5 x16 (OCP 4C+ connector)
RC 8: 3x16LP(G5) + 1x8/x16 OCP(G5) + 1xBOSS	R2c	1	Low Profile	Processor 1	PCIe Gen5 x16 (x16 connector)
		2	Low Profile	Processor 1	PCIe Gen5 x16 (x16 connector)
	BOSS	3	BOSS	Processor 0	PCIe Gen3 x4 (1C connector)
	R4a	4	Low Profile	Processor 0	PCIe Gen5 x16 (x16 connector)
	OCP	5	OCP	Processor 0	PCIe Gen5 x16 (OCP 4C+ connector)
RC 10: 2x16LP(G5) + 1x8/x16 OCP(G5) +1xBOSS	R2e	1	Low Profile	Processor 1	PCIe Gen5 x16 (x16 connector)
	BOSS	3	BOSS	Processor 0	PCIe Gen3 x4 (1C connector)
	R4a	4	Low Profile	Processor 0	PCIe Gen5 x16 (x16 connector)
	OCP	5	OCP	Processor 0	PCIe Gen5 x16 (OCP 4C+ connector)

**i** **NOTE:** The system supports either Front I/O configuration (system with front risers) or Rear I/O configuration (system with rear risers).

**Table 83. RC0. NO RSR**

Card type	Slot priority	Maximum number of cards
FOXCONN (BOSS)	3	1
Wistron (M.2 interposer)	3	1
Broadcom (OCP: 200Gb)	5	1

**Table 83. RC0. NO RSR (continued)**

Card type	Slot priority	Maximum number of cards
Broadcom (OCP: 100Gb)	5	1
Mellanox (OCP: 100Gb)	5	1
Broadcom (OCP: 25Gb)	5	1
Mellanox (OCP: 25Gb)	5	1
Intel (OCP: 10Gb)	5	1
Broadcom (OCP: 10Gb)	5	1
Broadcom (OCP: 1Gb)	5	1
Intel (OCP: 1Gb)	5	1

**Table 84. RC1: RF1a**

Card type	Slot priority	Maximum number of cards
Nvidia (DPU: 400Gb)	31,32	2
Nvidia (DPU: 200Gb)	31,32	2
Intel (DPU: 100Gb)	31,32	2
Nvidia ( L4 GPU)	31,32	2
FOXCONN (BOSS)	34	1
Wistron (M.2 interposer)	34	1
Broadcom (NIC: 200Gb)	31,32	2
Mellanox (NIC: 100Gb)	31,32	2
Broadcom (NIC: 100Gb)	31,32	2
Nvidia (NIC: 25Gb)	31,32	2
Broadcom (NIC: 25Gb)	31,32	2
Emulex (HBA: FC64)	31,32	2
Marvell (HBA: FC64)	31,32	2
Emulex (HBA: FC32)	31,32	2
Marvell (HBA: FC32)	31,32	2
Nvidia (NIC: NDR400)	31,32	2
FOXCONN (External Adapter PERC)	31,32	1

**Table 85. RC 2: RF1b**

Card type	Slot priority	Maximum number of cards
FOXCONN (BOSS)	34	1
Wistron (M.2 interposer)	34	1
Broadcom (OCP: 200Gb)	32,31	2
Broadcom (OCP: 100Gb)	32,31	2
Mellanox (OCP: 100Gb)	32,31	2
Broadcom (OCP: 25Gb)	32,31	2
Mellanox (OCP: 25Gb)	32,31	2
Intel (OCP: 10Gb)	32,31	2

**Table 85. RC 2: RF1b (continued)**

Card type	Slot priority	Maximum number of cards
Broadcom (OCP: 10Gb)	32,31	2
Broadcom (OCP: 1Gb)	32,31	2
Intel (OCP: 1Gb)	32,31	2

**Table 86. RC 5: R2b+R4b**

Card type	Slot priority	Maximum number of cards
Nvidia (DPU: 400Gb)	4,1	2
Nvidia (DPU: 200Gb)	4,1	2
Intel (DPU: 100Gb)	4,1	2
Nvidia (L4 GPU)	4,1	2
FOXCONN (BOSS)	3	1
Wistron (M.2 interposer)	3	1
FOXCONN (Front PERC12)	INT	1
FOXCONN (Front PERC13)	INT	1
Broadcom (OCP: 200Gb)	5	1
Broadcom (OCP: 100Gb)	5	1
Mellanox (OCP: 100Gb)	5	1
Broadcom (OCP: 25Gb)	5	1
Mellanox (OCP: 25Gb)	5	1
Intel (OCP: 10Gb)	5	1
Broadcom (OCP: 10Gb)	5	1
Broadcom (OCP: 1Gb)	5	1
Intel (OCP: 1Gb)	5	1
Broadcom (NIC: 200Gb)	4,1	2
Mellanox (NIC: 100Gb)	4,1	2
Broadcom (NIC: 100Gb)	4,1	2
Nvidia (NIC: 25Gb)	4,1	2
Broadcom (NIC: 25Gb)	4,1	2
Emulex (HBA: FC64)	4,1	2
Marvell (HBA: FC64)	4,1	2
Emulex (HBA: FC32)	4,1	2
Marvell (HBA: FC32)	4,1	2
Nvidia (NIC: NDR400)	4,1	2
SMART Modular Technologies (CXL)*	4,1	2
FOXCONN (External Adapter PERC)	4,1	1

 **NOTE:** \*Feature not available at product launch in September, 2025. Please refer to the product configurator page on Dell.com to confirm feature availability.

**Table 87. RC 6: R2f+R4a**

Card type	Slot priority	Maximum number of cards
Nvidia (L4 GPU)	4,1	2
FOXCONN (BOSS)	3	1
Wistron (M.2 interposer)	3	1
FOXCONN (Front PERC12)	INT	1
FOXCONN (Front PERC13)	INT	1
Broadcom (OCP: 200Gb)	5,2	2
Broadcom (OCP: 100Gb)	5,2	2
Mellanox (OCP: 100Gb)	5,2	2
Broadcom (OCP: 25Gb)	5,2	2
Mellanox (OCP: 25Gb)	5,2	2
Intel (OCP: 10Gb)	5,2	2
Broadcom (OCP: 10Gb)	5,2	2
Broadcom (OCP: 1Gb)	5,2	2
Intel (OCP: 1Gb)	5,2	2
Broadcom (NIC: 200Gb)	4,1	2
Broadcom (NIC: 100Gb)	4,1	2
Mellanox (NIC: 100Gb)	4,1	2
Nvidia (NIC: 25Gb)	4,1	2
Broadcom (NIC: 25Gb)	4,1	2
Emulex (HBA: FC64)	4,1	2
Marvell (HBA: FC64)	4,1	2
Emulex (HBA: FC32)	4,1	2
Marvell (HBA: FC32)	4,1	2
Nvidia (NIC: NDR400)	4,1	2
FOXCONN (External Adapter PERC)	4,1	1

**Table 88. RC8: R2c+R4a**

Card type	Slot priority	Maximum number of cards
Nvidia (L4 GPU)	2,4,1	3
FOXCONN (BOSS)	3	1
Wistron (M.2 interposer)	3	1
FOXCONN (Front PERC12)	INT	1
FOXCONN (Front PERC13)	INT	1
Broadcom (OCP: 200Gb)	5	1
Broadcom (OCP: 100Gb)	5	1
Mellanox (OCP: 100Gb)	5	1
Broadcom (OCP: 25Gb)	5	1
Mellanox (OCP: 25Gb)	5	1

**Table 88. RC8: R2c+R4a (continued)**

Card type	Slot priority	Maximum number of cards
Intel (OCP: 10Gb)	5	1
Broadcom (OCP: 10Gb)	5	1
Broadcom (OCP: 1Gb)	5	1
Intel (OCP: 1Gb)	5	1
Broadcom (NIC: 200Gb)	2,4,1	3
Broadcom (NIC: 100Gb)	2,4,1	3
Mellanox (NIC: 100Gb)	2,4,1	3
Nvidia (NIC: 25Gb)	2,4,1	3
Broadcom (NIC: 25Gb)	2,4,1	3
Emulex (HBA: FC64)	2,4,1	3
Marvell (HBA: FC64)	2,4,1	3
Emulex (HBA: FC32)	2,4,1	3
Marvell (HBA: FC32)	2,4,1	3
Nvidia (NIC: NDR400)	2,4,1	3
FOXCONN (External Adapter PERC)	2,4,1	1

**Table 89. RC10: R2e+R4a**

Card type	Slot priority	Maximum number of cards
Nvidia (L4 GPU)	4,1	2
FOXCONN (BOSS)	3	1
Wistron (M.2 interposer)	3	1
Broadcom (OCP: 200Gb)	5	1
Broadcom (OCP: 100Gb)	5	1
Mellanox (OCP: 100Gb)	5	1
Broadcom (OCP: 25Gb)	5	1
Mellanox (OCP: 25Gb)	5	1
Intel (OCP: 10Gb)	5	1
Broadcom (OCP: 10Gb)	5	1
Broadcom (OCP: 1Gb)	5	1
Intel (OCP: 1Gb)	5	1
Broadcom (NIC: 200Gb)	4,1	2
Broadcom (NIC: 100Gb)	4,1	2
Mellanox (NIC: 100Gb)	4,1	2
Nvidia (NIC: 25Gb)	4,1	2
Broadcom (NIC: 25Gb)	4,1	2
Emulex (HBA: FC64)	4,1	2
Marvell (HBA: FC64)	4,1	2
Emulex (HBA: FC32)	4,1	2

**Table 89. RC10: R2e+R4a (continued)**

Card type	Slot priority	Maximum number of cards
Marvell (HBA: FC32)	4,1	2
Nvidia (NIC: NDR400)	4,1	2
FOXCONN (External Adapter PERC)	4,1	1

## Removing the front expansion card risers

### Prerequisites

1. Follow the safety guidelines listed in the [Safety instructions](#).
2. Follow the procedure listed in the [Before working inside your system](#).
3. [Remove the cooling fans](#).
4. [Remove the drive backplane cover](#).
5. Disconnect the cables, observe the cable routing.

**NOTE:** See [cable routing](#) section for more information.

### Steps

For Front Riser 1a, disconnect the riser cables from the system board connectors connected through the side wall of the chassis. Using the Phillip 2 screw driver, loosen the thumb screw connecting the riser module to the chassis. Hold the riser and slide the expansion card riser from the systems.

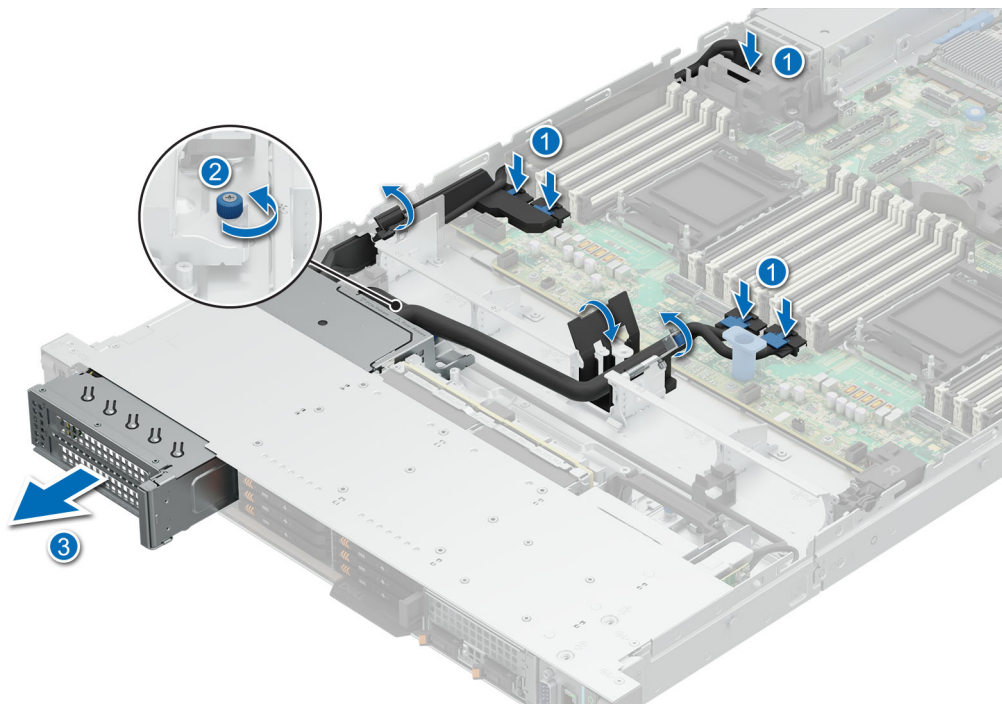

**Figure 136. Removing the front expansion card riser 1a (RF1a)**

### Next steps

1. [Replace the front expansion card riser](#).

# Installing the front expansion card risers

## Prerequisites

1. Follow the safety guidelines listed in the [Safety instructions](#).
2. Follow the procedure listed in [Before working inside your system](#).
3. [Remove the cooling fans](#).
4. [Remove the drive backplane cover](#).
5. If removed, [install the expansion cards into the expansion card risers](#).
6. Route and connect the cables, taking care not to damage them.

**NOTE:** See [cable routing](#) section for more information.

**CAUTION:** Do not install GPUs, network cards, or other PCIe devices on your system that are not validated and tested by Dell. Damage caused by unauthorized and invalidated hardware installation will null and void the system warranty.

## Steps

For Front Riser 1a, align and slide the expansion card riser into the system. Using the Phillip 2 screw driver, tighten the thumb screw connecting the riser module to the chassis. Reconnect the riser cables on the system board connectors connected through the side wall of the chassis.

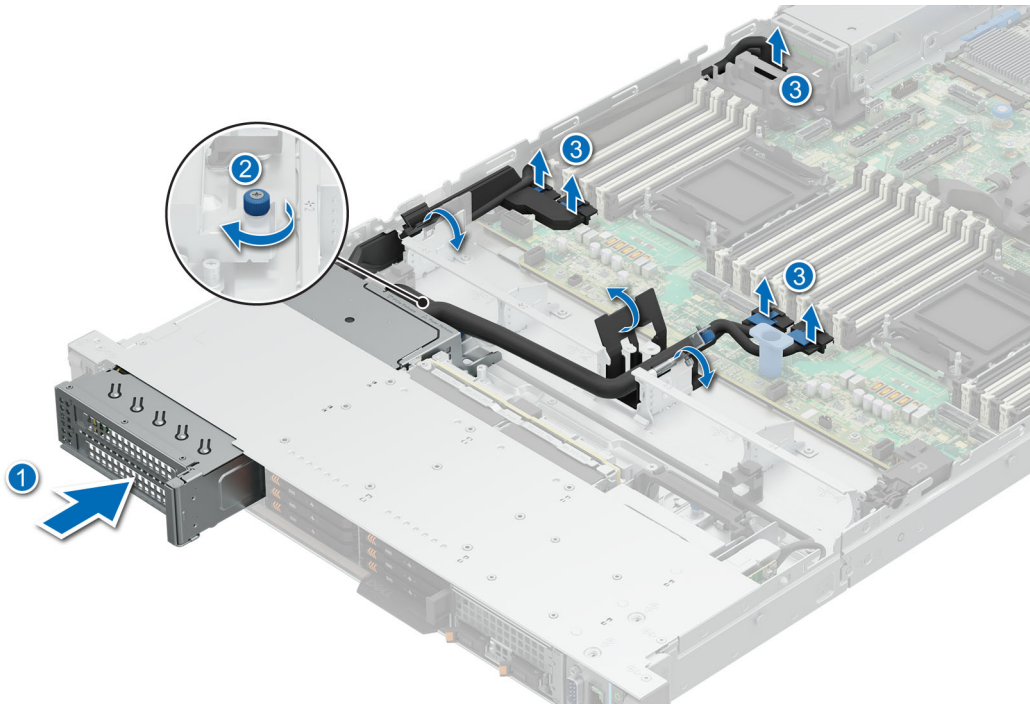

**Figure 137. Installing the front expansion card riser 1a (RF1a)**

## Next steps

1. Route and connect the cables, taking care not to damage them.

**NOTE:** See [cable routing](#) section for more information.

2. [Install the cooling fans](#).
3. [Install the drive backplane cover](#).
4. Follow the procedure listed in the [After working inside your system](#).

## Removing the rear expansion card risers

### Prerequisites

1. Follow the safety guidelines listed in the [Safety instructions](#).
2. Follow the procedure listed in the [Before working inside your system](#).
3. If applicable, disconnect the cables from the expansion card or system board.

### Steps

1. For Riser 2b, unlock the riser latch, lift the expansion card riser to disengage it from the riser connector, and carefully remove it from the guide pin and cage guide hole.

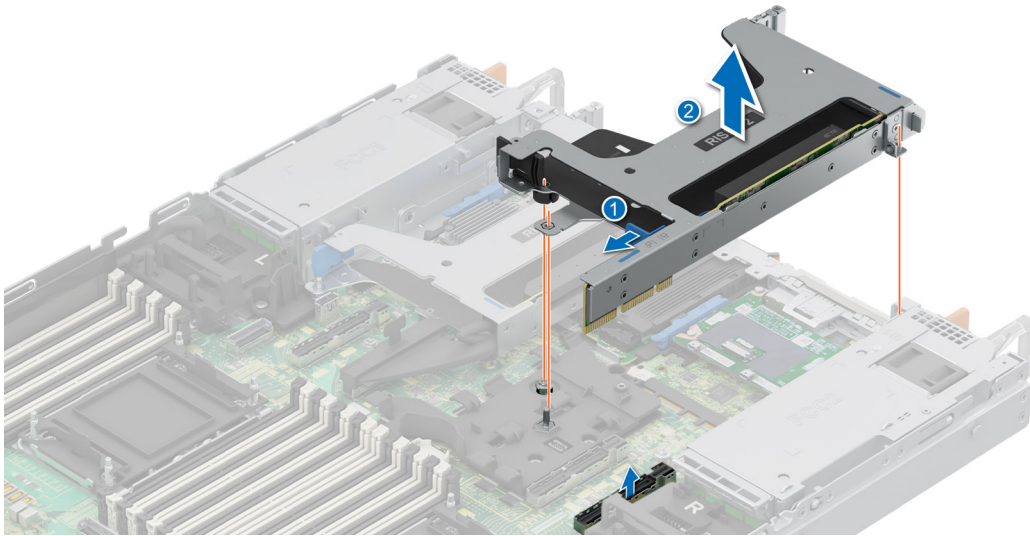

Figure 138. Removing the rear expansion card riser 2b (R2b)

2. For Riser 2f, disconnect the cable from the connector. Holding the touch points, lift the expansion card riser to disengage it from the connector and guide pin. Carefully remove it from the system board.

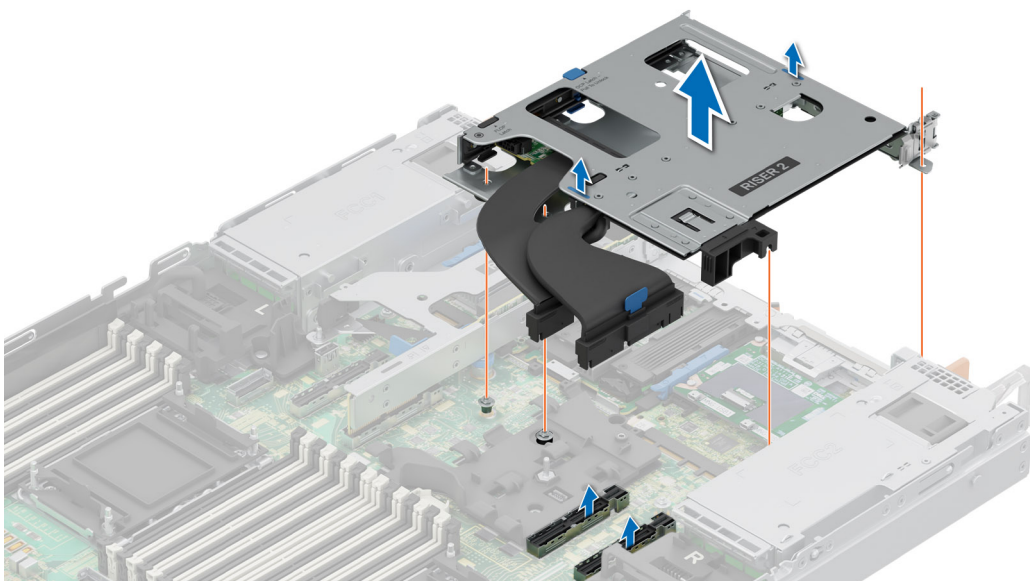
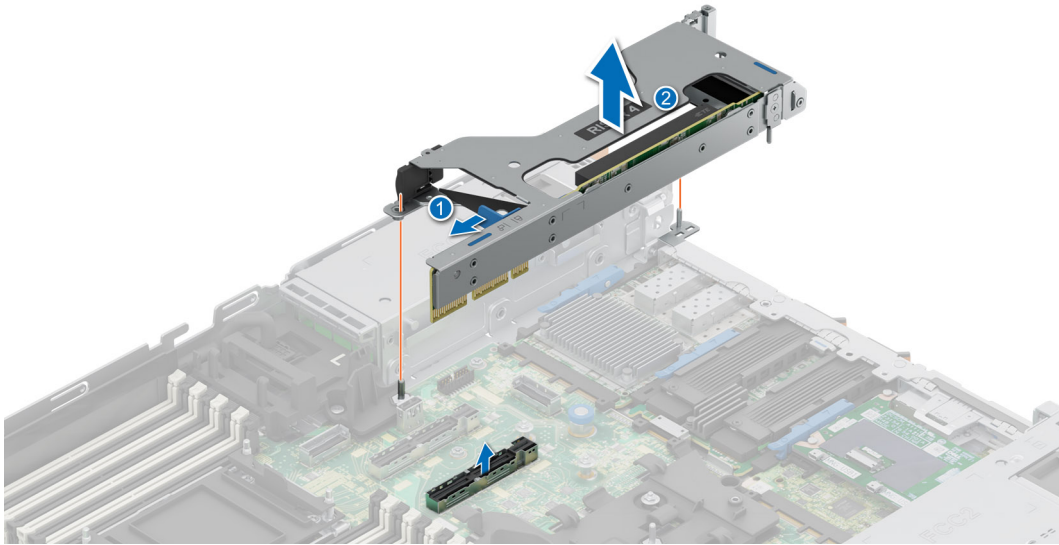

Figure 139. Removing the rear expansion card riser 2f (R2f)

3. For Riser 4a, unlock the riser latch. Lift the expansion card riser to disengage it from the connector and guide pin on the system board. Carefully remove the riser from the system.



**Figure 140. Removing the rear expansion card riser 4a (R4a)**

4. For Riser 4b, disconnect the cable from the connector. Lift the expansion card riser to disengage it from the connector and guide pin on the system board. Carefully remove the riser from the system.

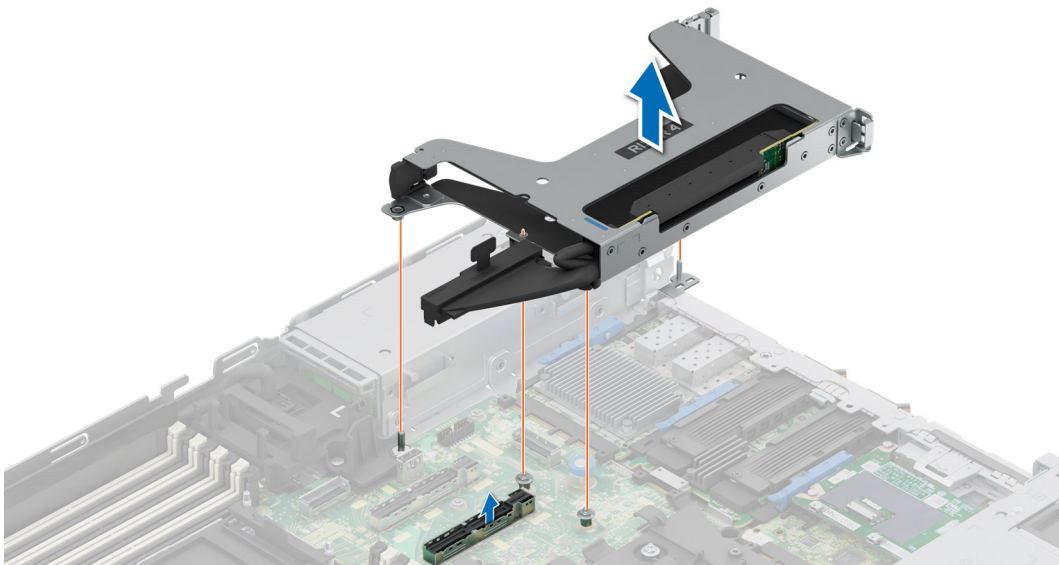

**Figure 141. Removing the rear expansion card riser 4b (R4b)**

#### **Next steps**

Replace the rear expansion card risers.

# Installing the rear expansion card risers

## Prerequisites

1. Follow the safety guidelines listed in the [Safety instructions](#).
2. Follow the procedure listed in the [Before working inside your system](#).
3. If removed, [install the expansion cards into the rear expansion card risers](#).

**CAUTION:** Do not install GPUs, network cards, or other PCIe devices on your system that are not validated and tested by Dell. Damage caused by unauthorized and invalidated hardware installation will null and void the system warranty.

## Steps

1. For Riser 2b, ensure the riser latch is unlocked, align the riser with the connector and guide pin, lower it into place, press to ensure the riser is fully seated on the connector, and then push the riser latch to lock.

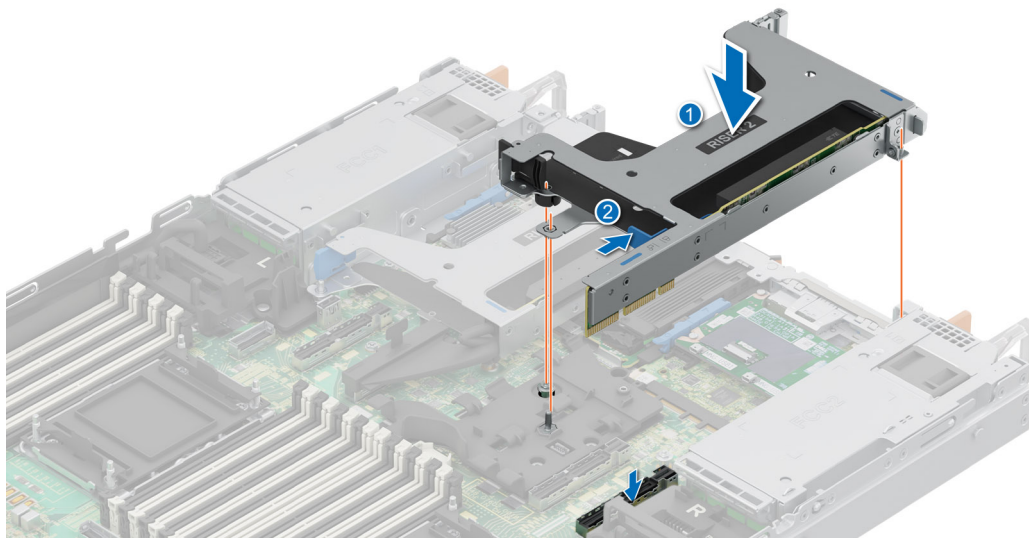

**Figure 142. Installing the rear expansion card riser 2b (R2b)**

2. For Riser 2f, reconnect the cable first to the connector. Align the expansion card riser with the connector and the riser guide pin on the system board. Lower the expansion card riser into place until the expansion card riser connector is fully seated in the connector. Push the blue touch point to ensure secure engagement.

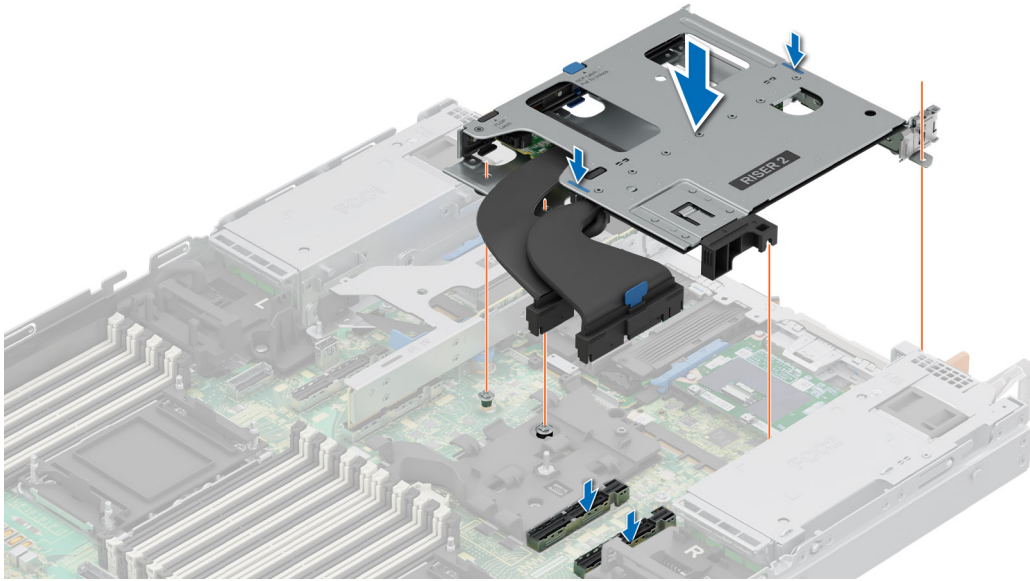

**Figure 143. Installing the rear expansion card riser 2f (R2f)**

3. For Riser 4a, ensure the riser latch is unlocked. Align the expansion card riser with the connector and the riser guide pin on the system board. Lower the expansion card riser into place until the expansion card riser connector is fully seated in the connector. Push the touch point to ensure secure engagement into connector, then lock the latch.

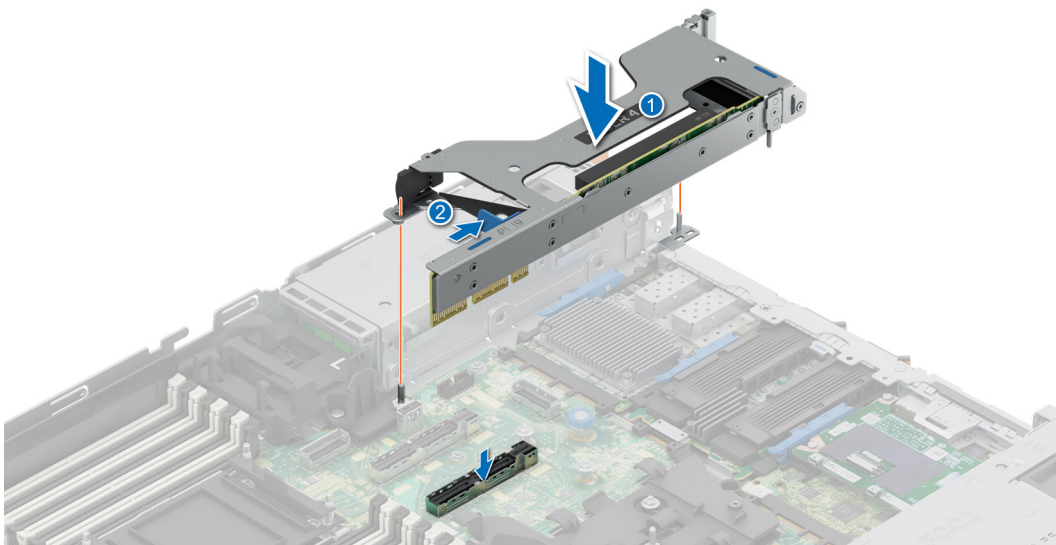

**Figure 144. Installing the rear expansion card riser 4a (R4a)**

4. For Riser 4b, reconnect the cable first to the connector. Align the expansion card riser with the connector and the riser guide pin on the system board. Lower the expansion card riser into place until the expansion card riser connector is fully seated in the connector. Press the touch points (indicated by blue line) to ensure proper engagement.

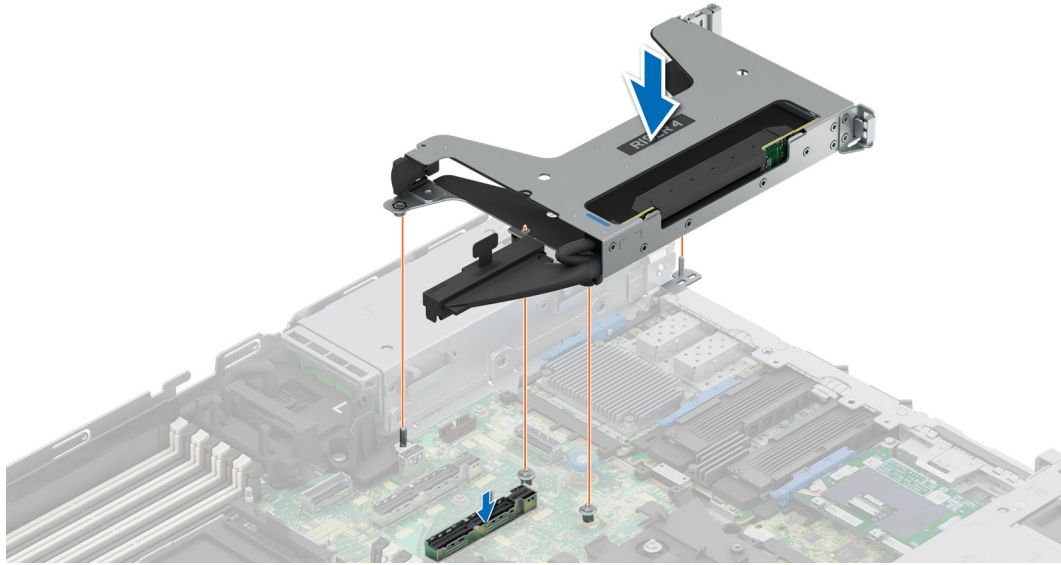

**Figure 145. Installing the rear expansion card riser 4b (R4b)**

#### Next steps

1. If required, reconnect the cables to the expansion card or system board.
2. Follow the procedure listed in [After working inside your system](#).

## Removing an expansion card from the expansion card riser

#### Prerequisites

1. Follow the safety guidelines listed in the [Safety instructions](#).
2. Follow the procedure listed in [Before working inside your system](#).
3. If applicable, disconnect the cables from the expansion card.
4. [Remove the front expansion card riser](#) or [remove the rear expansion card riser](#).

#### Steps

1. For front risers:
  - a. Unlock the plunger and open the side wall of the front riser.  
**NOTE:** If a low-profile card is installed, the card holder will be installed on the rotation side wall of the riser to secure the card properly.
  - b. Hold the expansion card by its edges and pull the card until the card edge connector disengages from the expansion card connector on the riser.

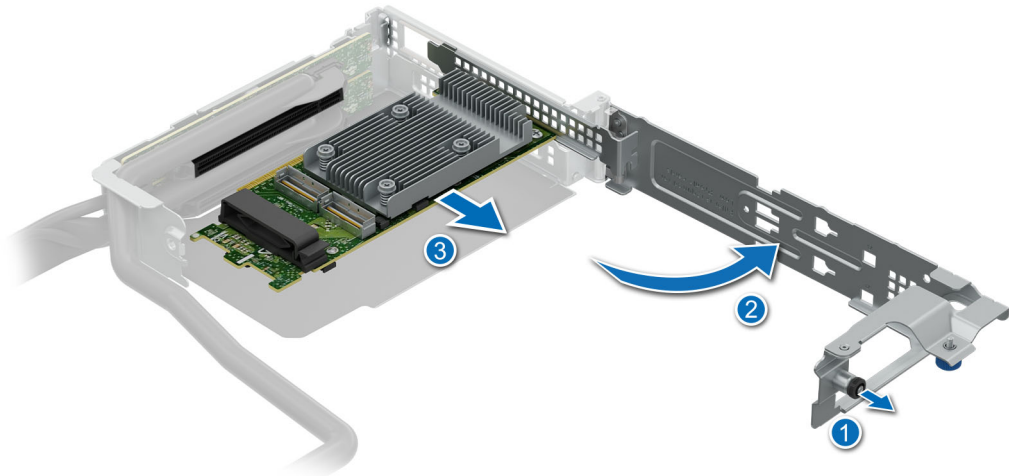
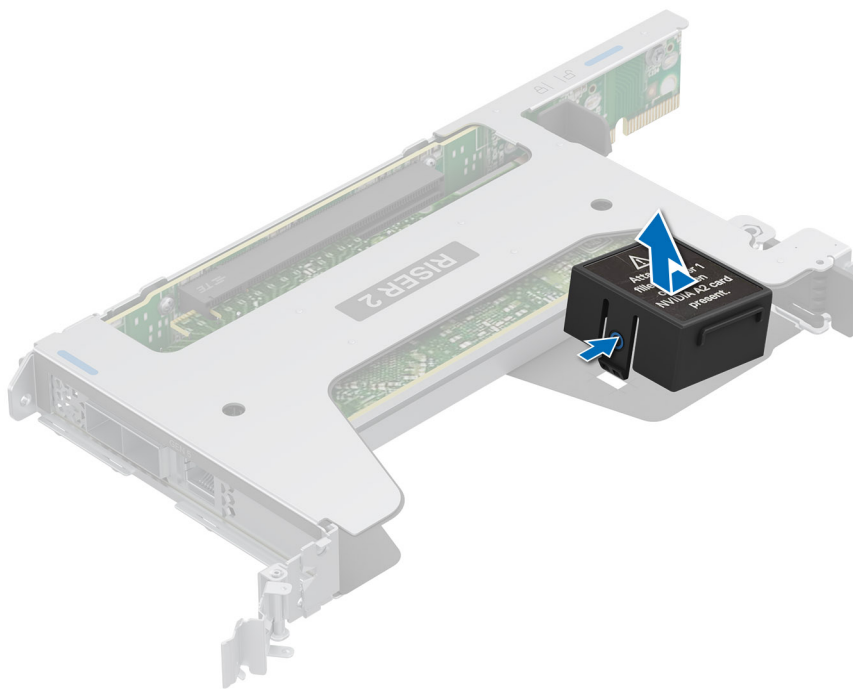

**Figure 146. Removing expansion card from the front expansion card riser**

2. For Riser 2b:

- a. Pull and lift up the expansion card retention latch lock to open.

**NOTE:** If a low-profile card is installed, the LP GPU blank will be installed on the riser wall to secure the card properly and should be removed from the wall before removing the expansion card.



**Figure 147. Removing GPU blank from the rear expansion card riser 2b**

- b. Hold the expansion card by its edges and pull the card until the card edge connector disengages from the expansion card connector on the riser.

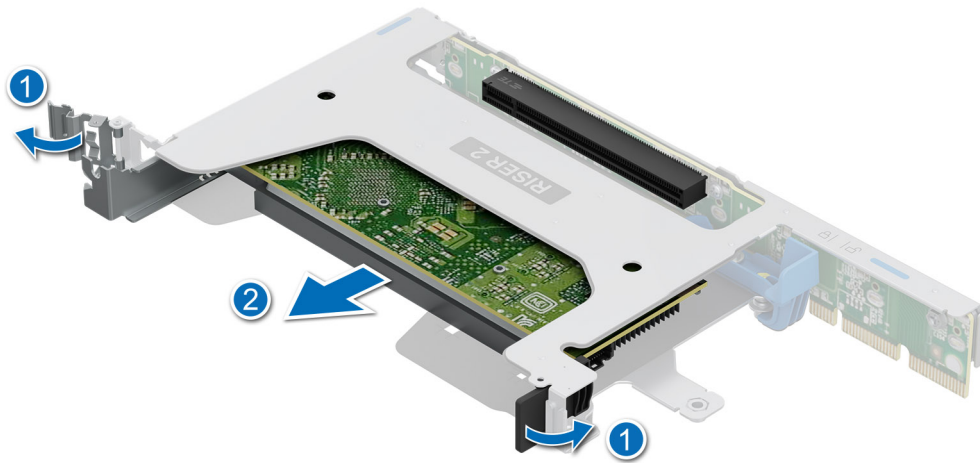
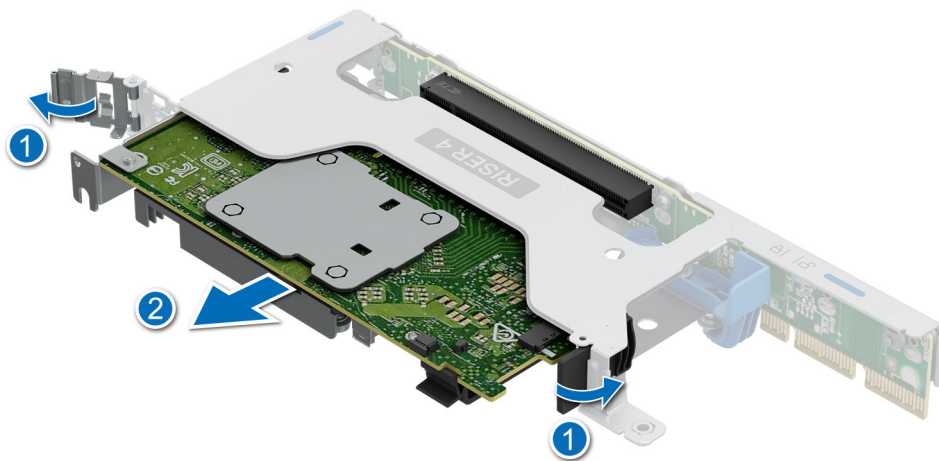

**Figure 148. Removing expansion card from the rear expansion card riser 2b**

**NOTE:** The numbers on the image do not depict the exact steps. The numbers are for representation of sequence.

3. For Riser 4a:
  - a. Pull and lift up the expansion card retention latch lock to open at both the ends.
  - b. Hold the expansion card by its edges and pull the card until the card edge connector disengages from the expansion card connector on the riser.

**NOTE:** The numbers on the image do not depict the exact steps. The numbers are for representation of sequence.



**Figure 149. Removing expansion card from the rear expansion card riser 4a**

4. For Riser 4b:
  - a. Pull and lift up the expansion card retention latch lock to open at both the ends.
  - b. Hold the expansion card by its edges and pull the card until the card edge connector disengages from the expansion card connector on the riser.

**i** | **NOTE:** The numbers on the image do not depict the exact steps. The numbers are for representation of sequence.

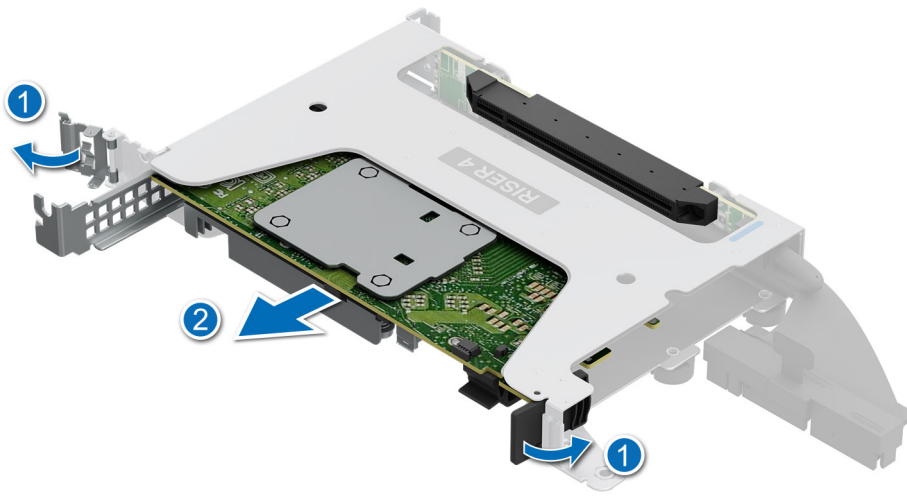
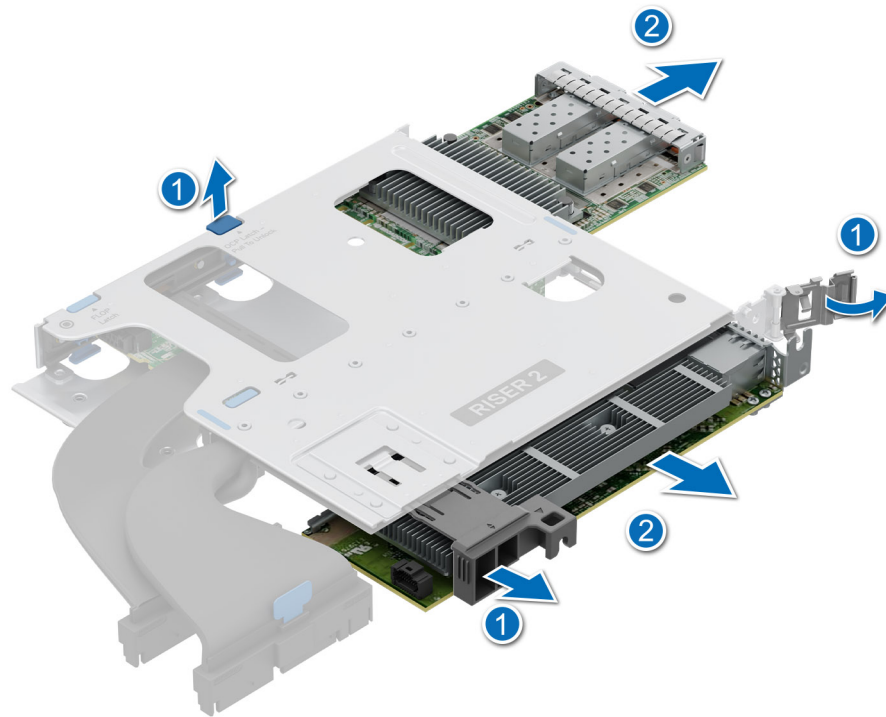

**Figure 150. Removing expansion card from the rear expansion card riser 4b**

5. For Riser 2f:

- a. To remove the expansion card, pull and lift up the retention latch lock to open. Hold the expansion card by its edges and pull the card until the card edge connector disengages from the expansion card connector on the riser.
- b. To remove the OCP NIC card, press the blue latch to disengage the OCP NIC card. Pull the OCP NIC card away from the system.

**i** | **NOTE:** The numbers on the image do not depict the exact steps. The numbers are for representation of sequence.



**Figure 151. Removing an expansion card and OCP NIC card from the riser 2f**

6. If the expansion card is not going to be replaced on risers, install a PCIe blank and close the card holder on both ends of the riser.

**i** **NOTE:** You must install a PCIe blank over an empty expansion card slot to maintain Federal Communications Commission (FCC) certification of the system. The blank also keep dust and dirt out of the system and aid in proper cooling and airflow inside the system.

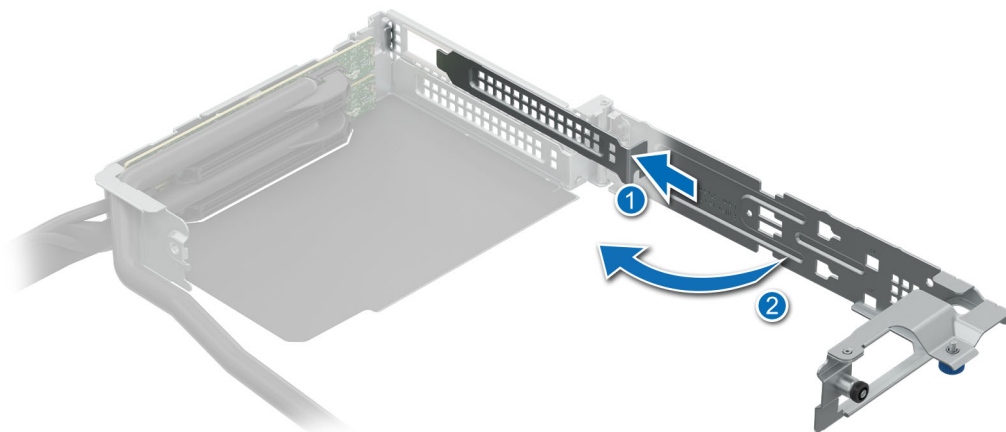

**Figure 152. Installing the PCIe blank for front riser**

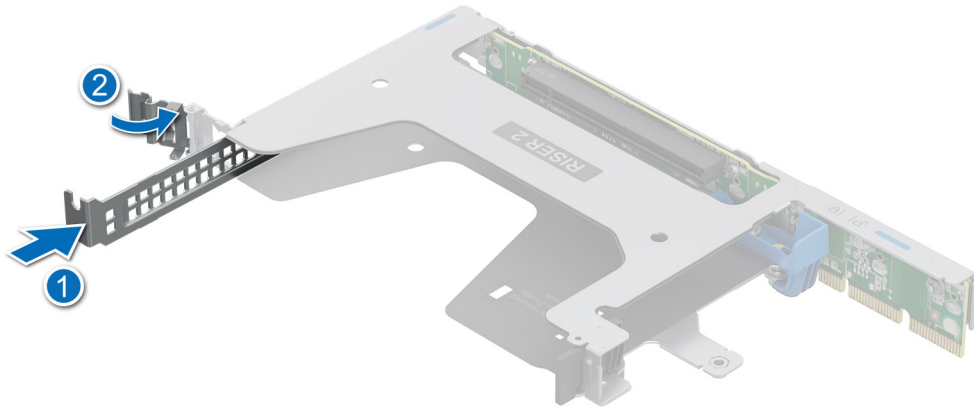

Figure 153. Installing the PCIe blank for riser 2b

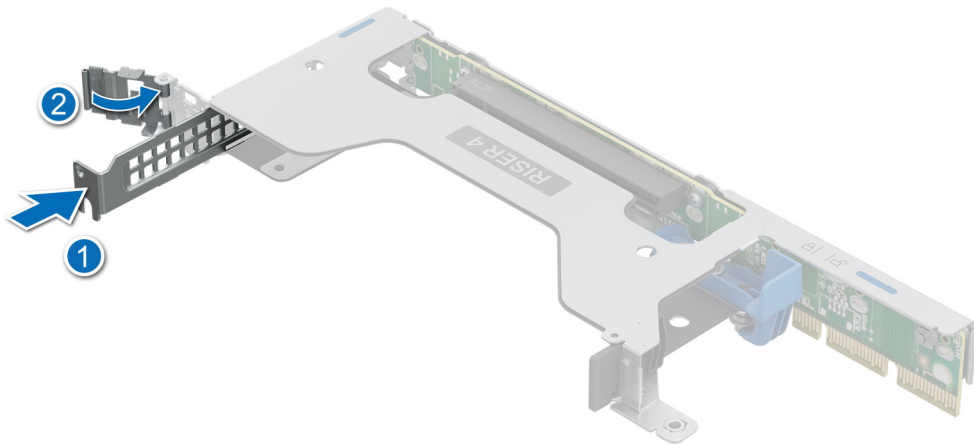

Figure 154. Installing the PCIe blank for riser 4a

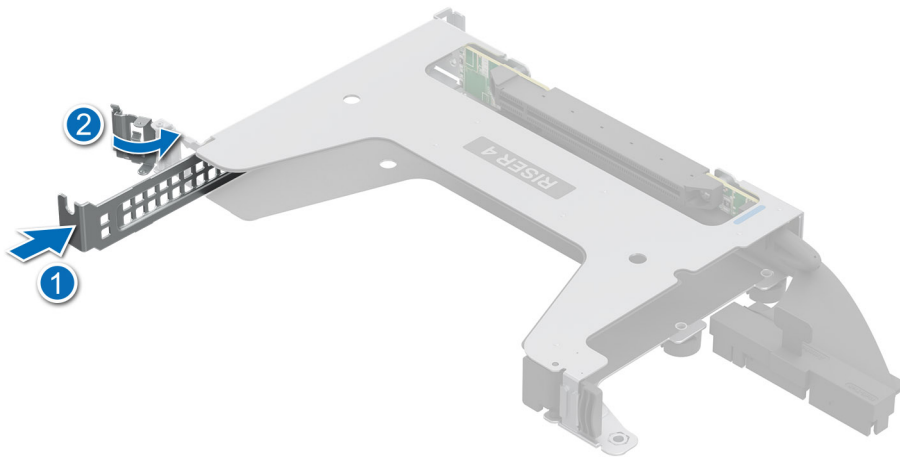

Figure 155. Installing the PCIe blank for riser 4b

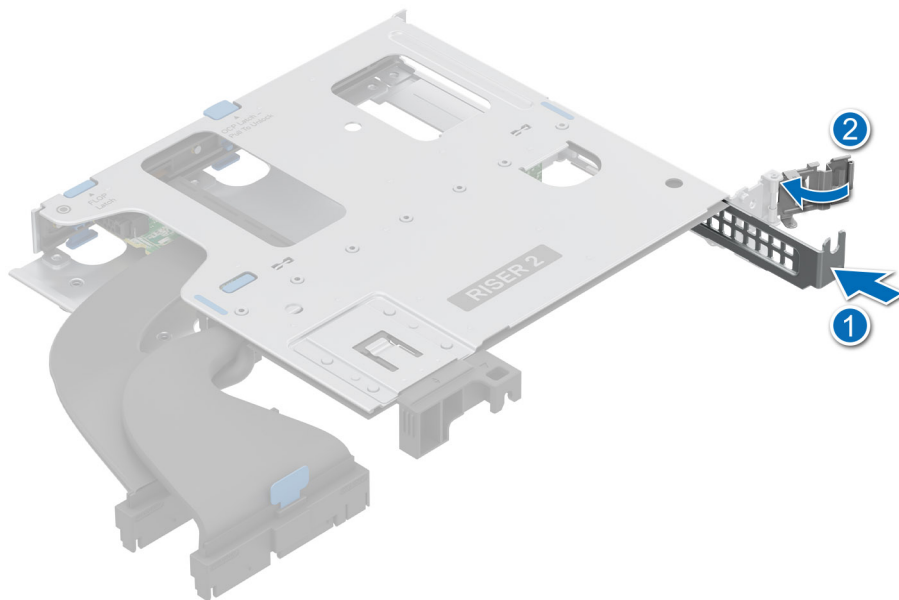

Figure 156. Installing the PCIe blank for riser 2f

#### Next steps

If applicable, [install an expansion card into the expansion card riser](#).

## Installing an expansion card into the expansion card riser

#### Prerequisites

1. Follow the safety guidelines listed in the [Safety instructions](#).
2. Follow the procedure listed in [Before working inside your system](#).
3. [Remove the front expansion card riser](#) or [remove the rear expansion card riser](#).
4. If installing a new expansion card, unpack it and prepare the card for installation.

**NOTE:** For instructions, see the documentation accompanying the card.

**CAUTION:** Do not install GPUs, network cards, or other PCIe devices on your system that are not validated and tested by Dell. Damage caused by unauthorized and invalidated hardware installation will null and void the system warranty.

### Steps

1. Pull and lift up the expansion card retention latch lock to open.

**NOTE:** For front risers, unlock the plunger and open the side wall of the front riser.

2. If installed, remove the PCIe blank from the risers.

**NOTE:** Store the PCIe blank for future use. PCIe blank must be installed in empty expansion card slots to maintain Federal Communications Commission (FCC) certification of the system. The blank also keep dust and dirt out of the system and aid in proper cooling and airflow inside the system.

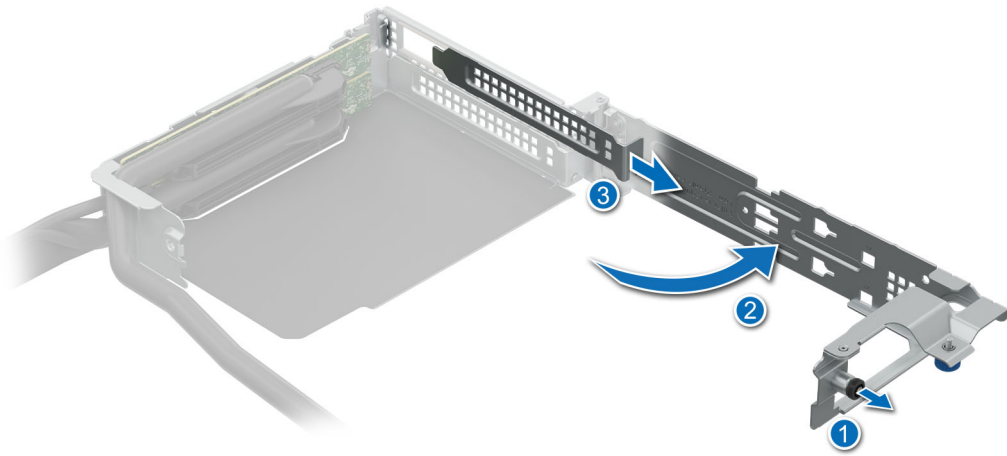

Figure 157. Removing the PCIe blank for the front riser

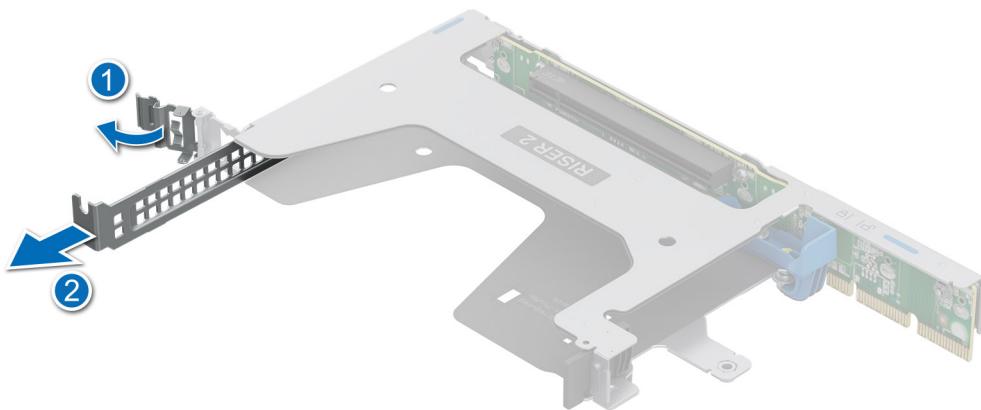

Figure 158. Removing the PCIe blank for the riser 2b

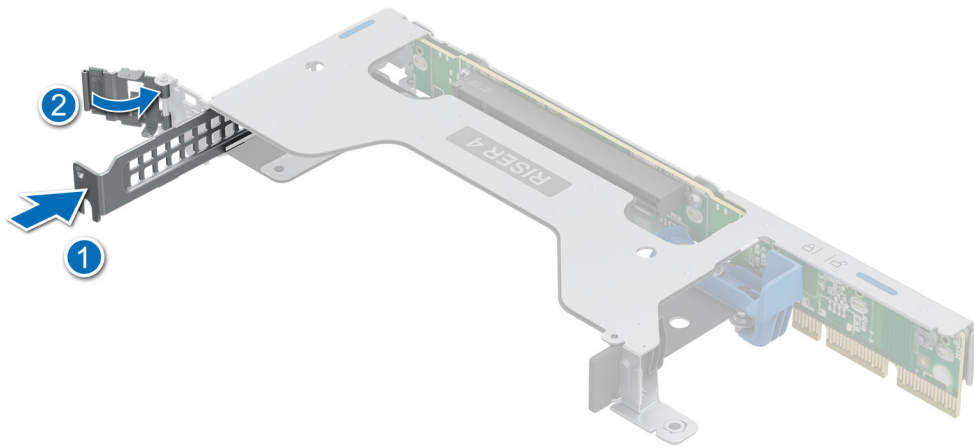

Figure 159. Removing the PCIe blank for the riser 4a

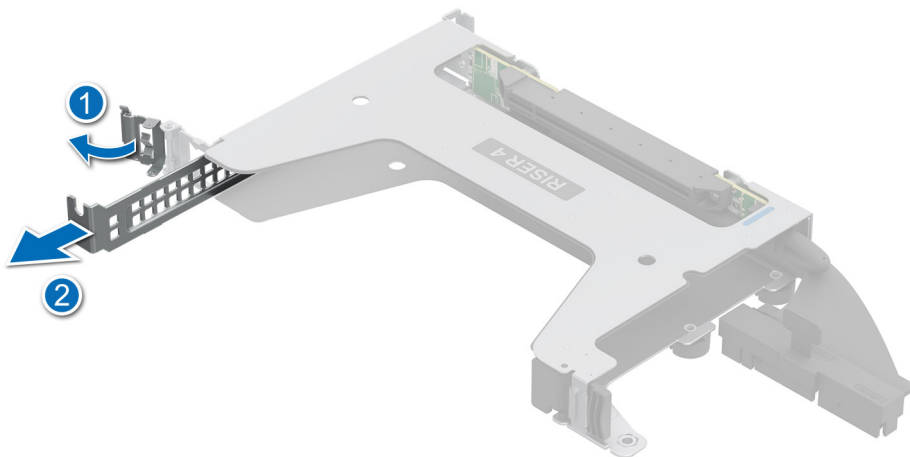
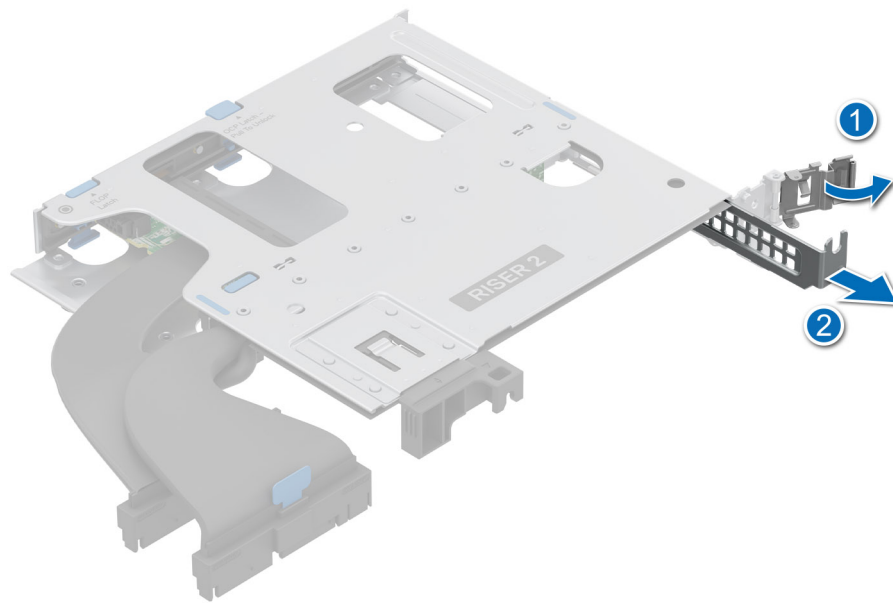

Figure 160. Removing the PCIe blank for the riser 4b



**Figure 161. Removing the PCIe blank for the riser 2f**

3. For front risers:

- a. Unlock the plunger and open the side wall of the front riser.
- b. If installed, remove the PCIe blank from the slot.

**i** **NOTE:** If not already installed, install the card holder onto the rotation side wall if using an LP card, ensuring alignment with the cage, and push to lock securely.

- c. Hold the card by the edges, and align the card edge connector with the expansion card connector on the riser.
- d. Insert the card edge connector firmly into the expansion card connector until the card is fully seated.
- e. Close the side wall of the front riser.

**i** **NOTE:** The plunger will auto-lock when the side wall is closed, securing the PCIe card.

**i** **NOTE:** The numbers on the image do not depict the exact steps. The numbers are for representation of sequence.

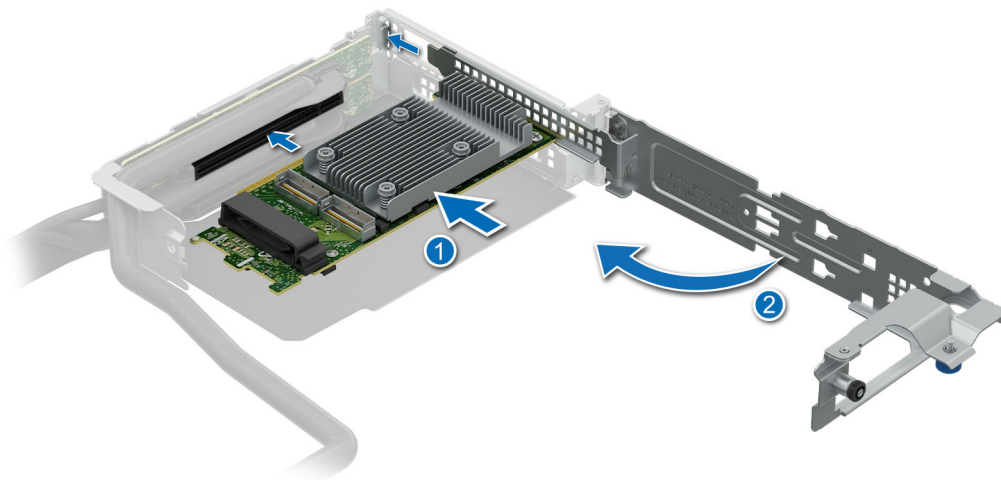

**Figure 162. Installing an expansion card into the front riser**

4. For riser 2b:

- a. Hold the card by the edges, and align the card edge connector with the expansion card connector on the riser.
- b. Insert the card edge connector firmly into the expansion card connector until the card is fully seated.
- c. Align and slide the card holder guides into the slots on the riser until seated.
- d. Close the expansion card retention latch on both ends of the riser.

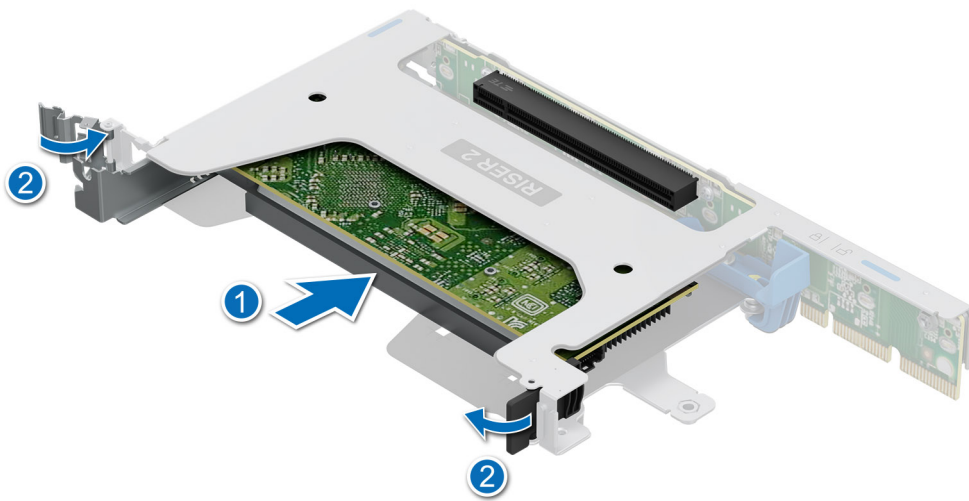

**Figure 163. Installing an expansion card into the riser 2b**

- e. If installing a Low Profile card, align the LP GPU blank on the Riser 2b wall and ensure the blank hook is securely fixed in place.

**NOTE:** The numbers on the image do not depict the exact steps. The numbers are for representation of sequence.

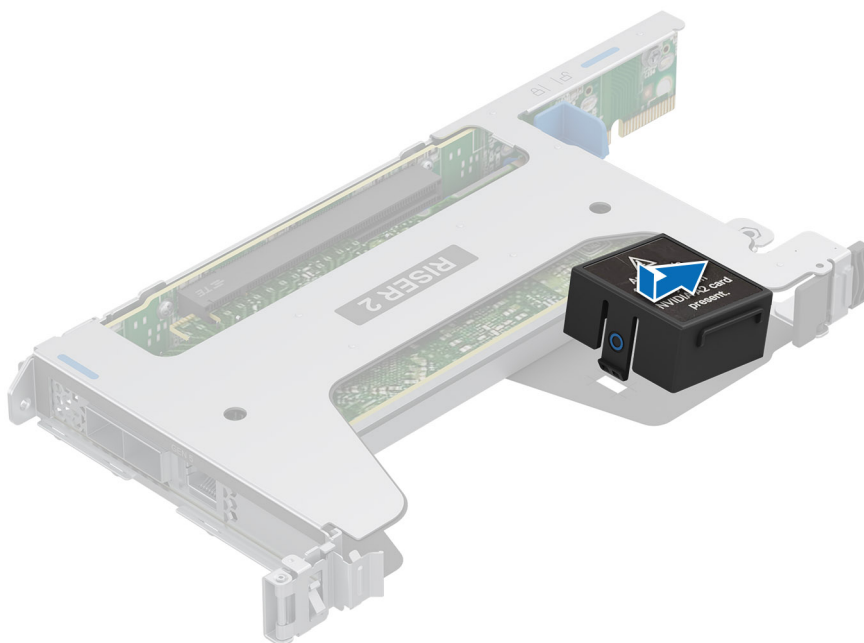
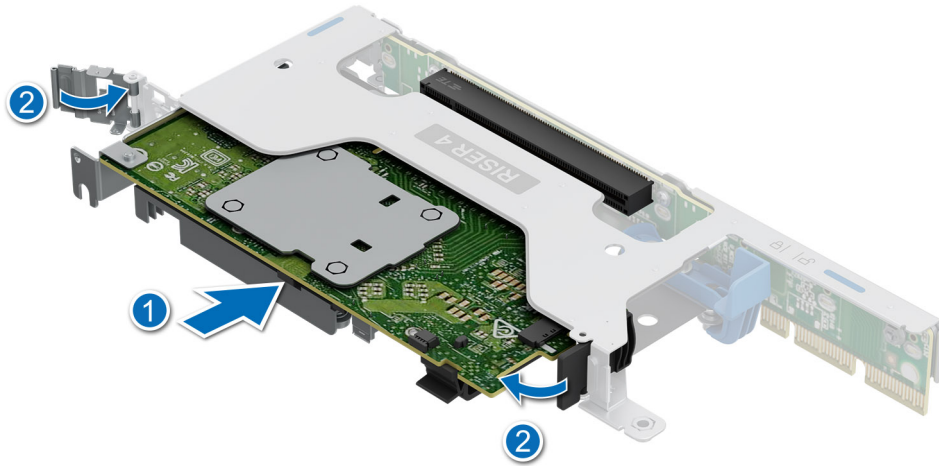

**Figure 164. Installing GPU blank on the rear expansion card riser 2b**

5. For riser 4a:
  - a. Hold the card by the edges, and align the card edge connector with the expansion card connector on the riser.

- b. Insert the card edge connector firmly into the expansion card connector until the card is fully seated.
- c. Align and slide the card holder guides into the slots on the riser until seated.
- d. Close the expansion card retention latch on both ends of the riser.

**i** **NOTE:** The numbers on the image do not depict the exact steps. The numbers are for representation of sequence.



**Figure 165. Installing an expansion card into the riser 4a**

- 6. For riser 4b:
  - a. Hold the card by the edges, and align the card edge connector with the expansion card connector on the riser.
  - b. Insert the card edge connector firmly into the expansion card connector until the card is fully seated.
  - c. Align and slide the card holder guides into the slots on the riser until seated.
  - d. Close the expansion card retention latch on both ends of the riser.

**i** **NOTE:** The numbers on the image do not depict the exact steps. The numbers are for representation of sequence.

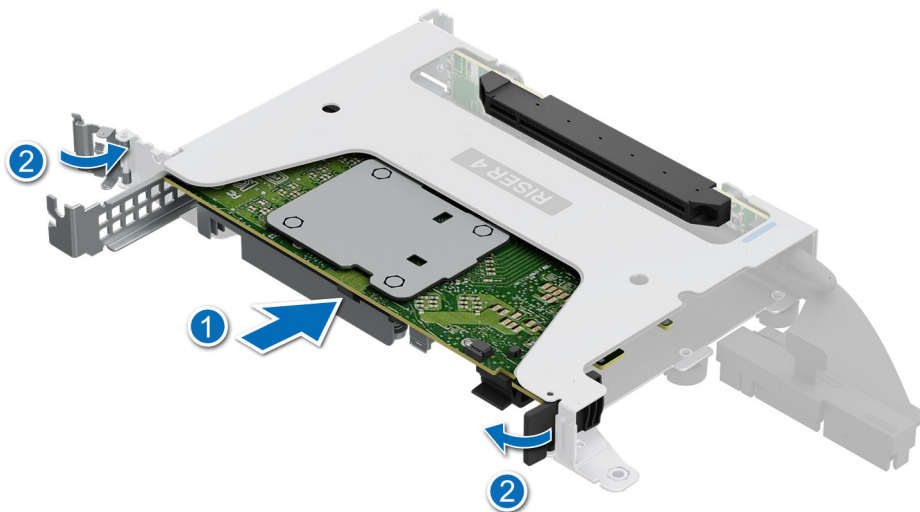
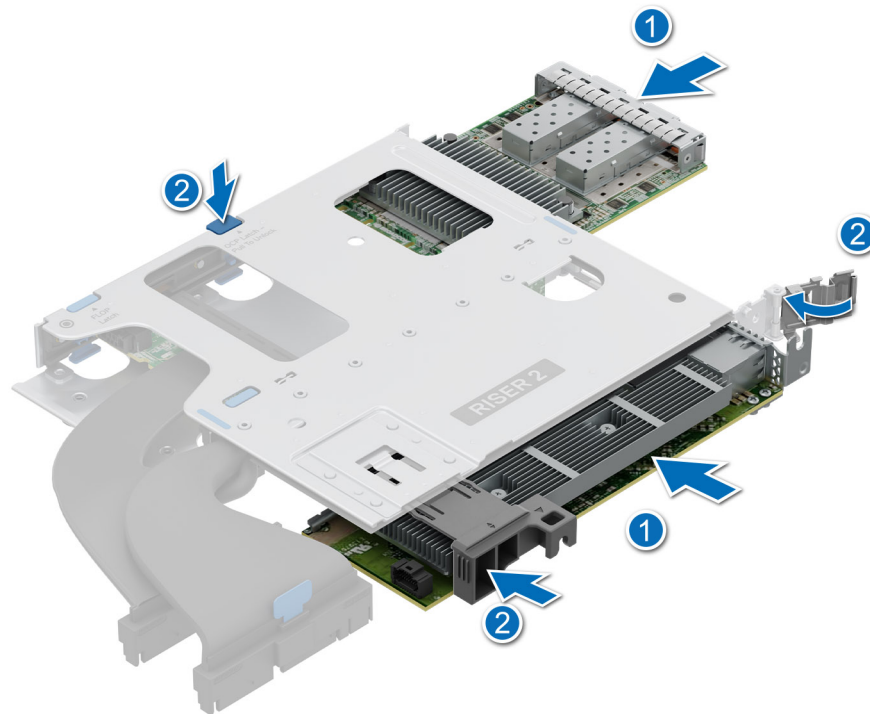

**Figure 166. Installing an expansion card into the riser 4b**

- 7. For OCP riser 2f:

- a. To install the expansion card, hold the card by the edges, and align the card edge connector with the expansion card connector on the riser. Insert the card edge connector firmly into the expansion card connector until the card is fully seated. Align and slide the card holder guides into the slots on the riser until seated. Close the expansion card retention latch on the end of the riser.
- b. To install the OCP, align and insert the OCP NIC card into the the system. Push until the OCP NIC card is connected to the connector on the riser. Press the blue release to lock the OCP into the riser.

**NOTE:** The numbers on the image do not depict the exact steps. The numbers are for representation of sequence.



**Figure 167. Installing an expansion card into the riser 2f**

#### Next steps

1. If applicable, connect the cables to the expansion card.
2. [Install the front expansion card riser](#) or [install the rear expansion card riser](#).
3. Follow the procedure listed in the [After working inside your system](#).
4. Install any device drivers required for the card as described in the documentation for the card.

## Removing the rear expansion card riser blank

#### Prerequisites

1. Follow the safety guidelines listed in the [Safety instructions](#).
2. Follow the procedure listed in the [Before working inside your system](#).

#### Steps

Using Phillips 2 screwdriver, loosen the 3 thumb screws securing the riser blank, then lift it up and away from the system board.

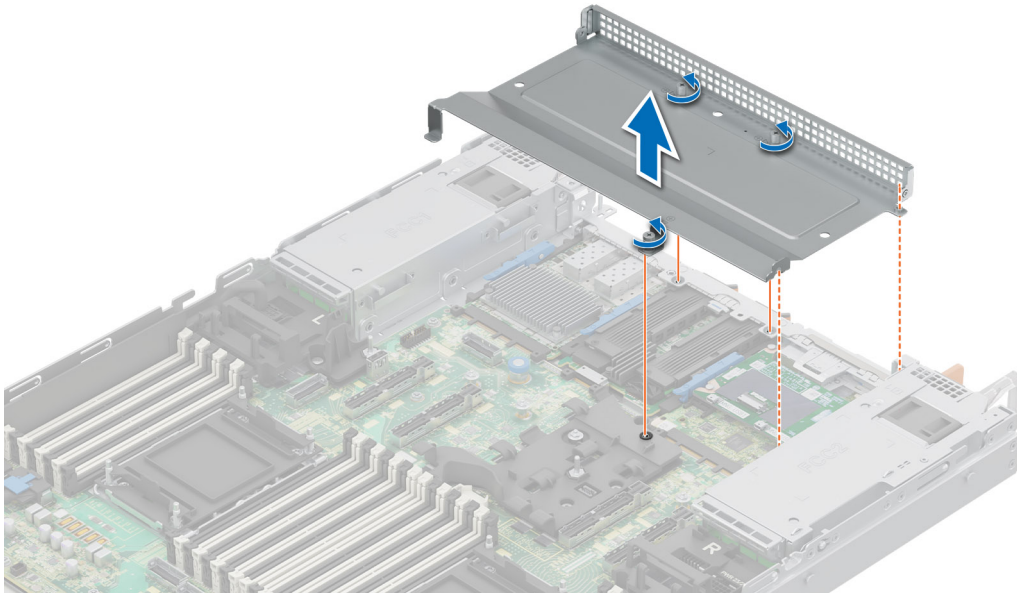

**Figure 168. Removing the rear expansion card riser blank**

**Next steps**

Replace the rear expansion card risers.

## Installing the rear expansion card riser blank

**Prerequisites**

1. Follow the safety guidelines listed in the [Safety instructions](#).
2. Follow the procedure listed in the [Before working inside your system](#).

**Steps**

Align the riser blank with the blank alignment guide pin and T-pin, then use a Phillips 2 screwdriver to fasten the 3 thumb screws.

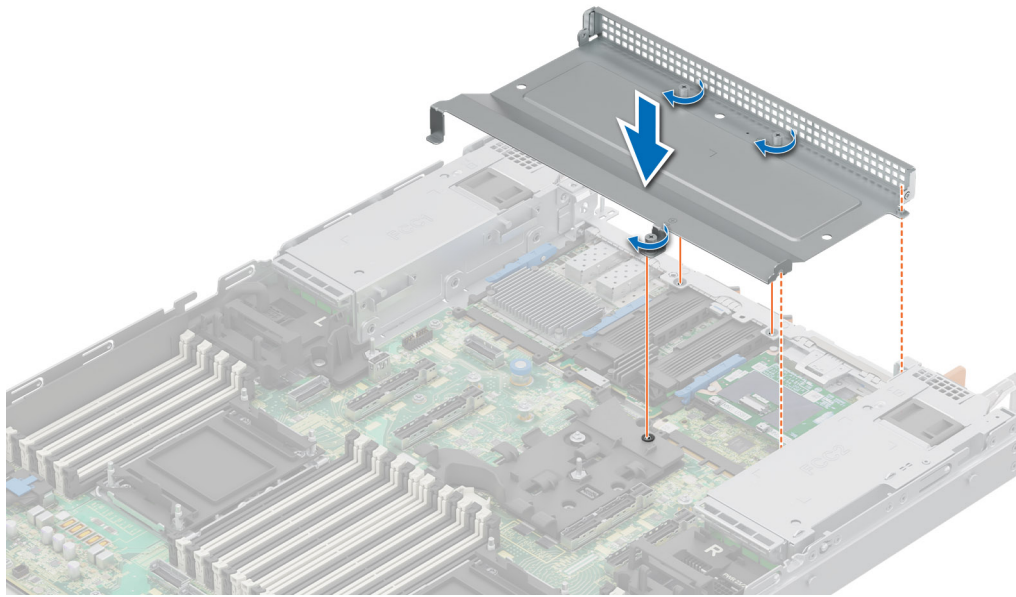

Figure 169. Installing the rear expansion card riser blank

#### Next steps

1. Follow the procedure listed in [After working inside your system](#).

## M.2 SSD module

**NOTE:** For information about Thermal pad and BOSS-N1 card carrier replacement, go to [PowerEdge Manuals > Rack Servers > PowerEdge R670 > Select This Product > Documentation > Manuals and Documents > BOSS-N1 DC-MHS M.2 NVMe SSD Card Installation and BOSS-N1 DC-MHS carrier Replacement Tech Sheet](#).

**NOTE:** For information about M.2 Interposer board replacement and M.2 NVMe SSD module installation, go to [PowerEdge Manuals > Rack Servers > PowerEdge R670 > Select This Product > Documentation > Manuals and Documents > M.2 Interposer board - Replacement and M.2 NVMe SSD module - Installation Tech Sheet](#).

## Removing the M.2 NVMe SSD module from the BOSS-N1 DC-MHS card carrier

#### Prerequisites

1. Follow the safety guidelines listed in the [Safety instructions](#).
2. Follow the procedure listed in [Before working inside your system](#).

#### Steps

1. Pull and lift the BOSS-N1 DC-MHS card carrier retention latch lock to open.
2. Slide the BOSS-N1 DC-MHS card carrier out.

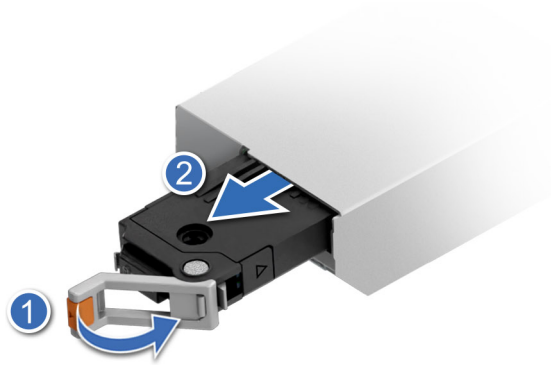

**Figure 170. Removing the BOSS-N1 DC-MHS card carrier**

- Using the Phillips 1 screwdriver, loosen the captive screws securing the top cover of the BOSS-N1 DC-MHS card carrier.  
**NOTE:** Follow the sequence to loosen the captive screws. First, loosen the screw at the connector end, and then the screw at the front handle end.



**Figure 171. Loosen the top cover captive screws**

- Tilt the top cover from the side and lift the top cover out of the BOSS-N1 DC-MHS card carrier.



**Figure 172. Removing the top cover**

- Lift the M.2 NVMe SSD module and then slowly pull the card outward to disconnect from the connector.

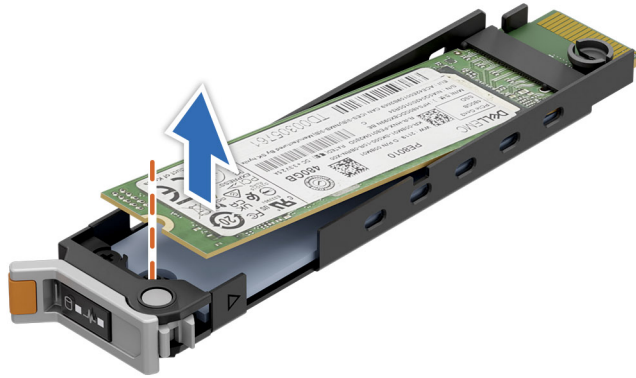

Figure 173. Removing the M.2 NVMe SSD module

#### Next steps

1. Replace the M.2 NVMe SSD module in the BOSS-N1 DC-MHS card carrier.

## Installing the M.2 NVMe SSD module in the BOSS-N1 DC-MHS card carrier

#### Prerequisites

1. Follow the safety guidelines listed in the [Safety instructions](#).
2. Follow the procedure listed in [Before working inside your system](#).

#### Steps

1. Remove the thermal pads on the top cover and bottom cover of the BOSS-N1 DC-MHS card carrier, when replacing the M.2 NVMe SSD module.

**i** **NOTE:** The removed thermal pad cannot be reused for installingInstalling the new thermal pads inside the BOSS-N1 DC-MHS card carriers the M.2 NVMe SSD module. You must use the new thermal pads for installing the M.2 NVMe SSD module.

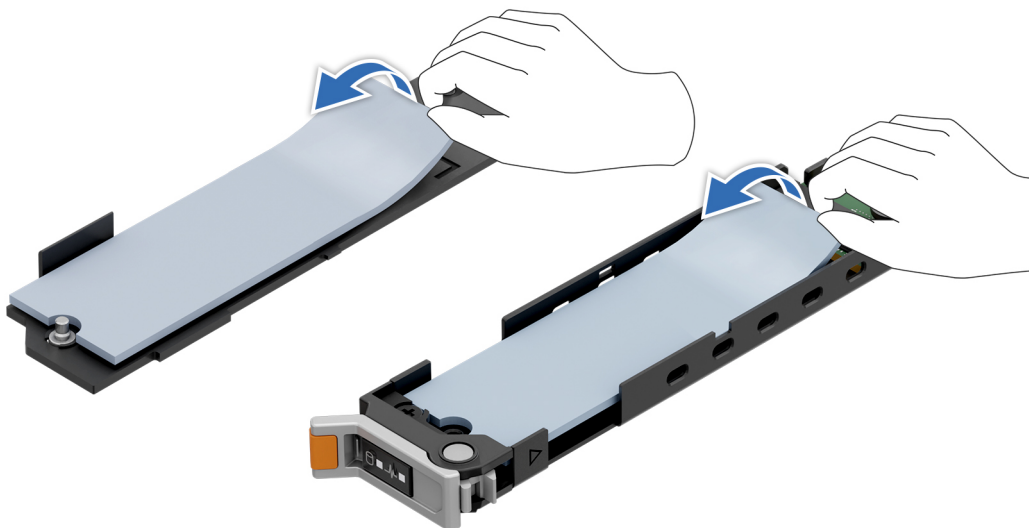

Figure 174. Removing the old thermal pads on the top and bottom of the BOSS-N1 DC-MHS card carriers

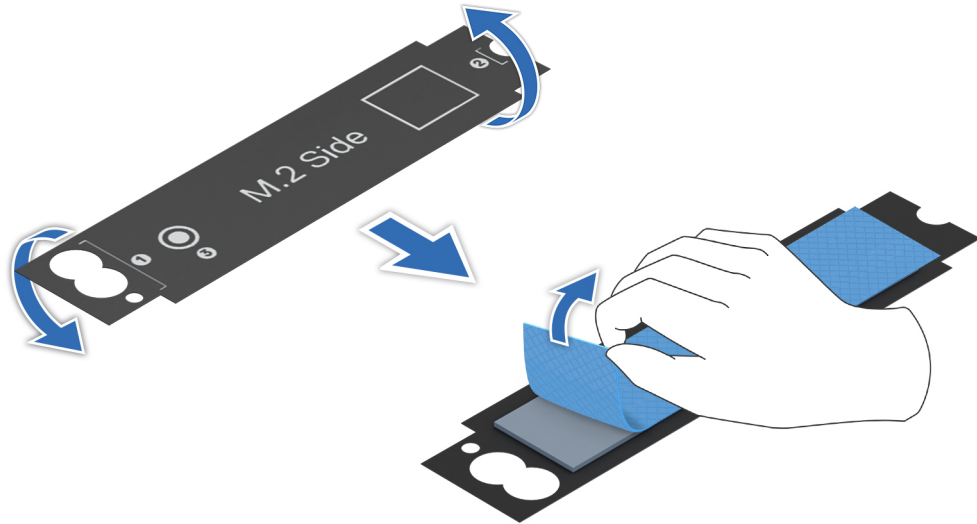

Figure 175. Flip the new thermal pads and removing the blue film

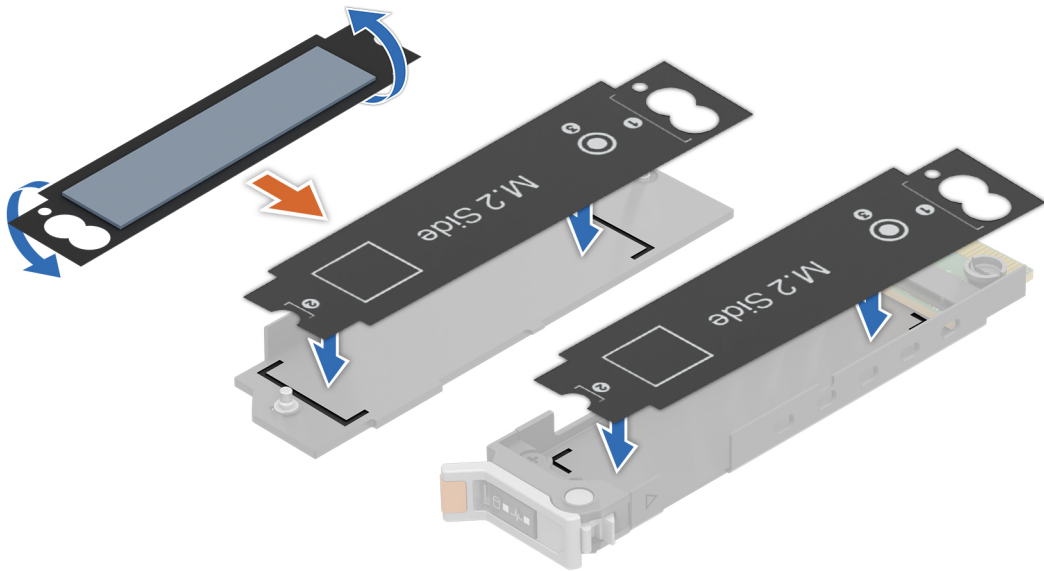

Figure 176. Installing the new thermal pads on the top and bottom of the BOSS-N1 DC-MHS card carriers

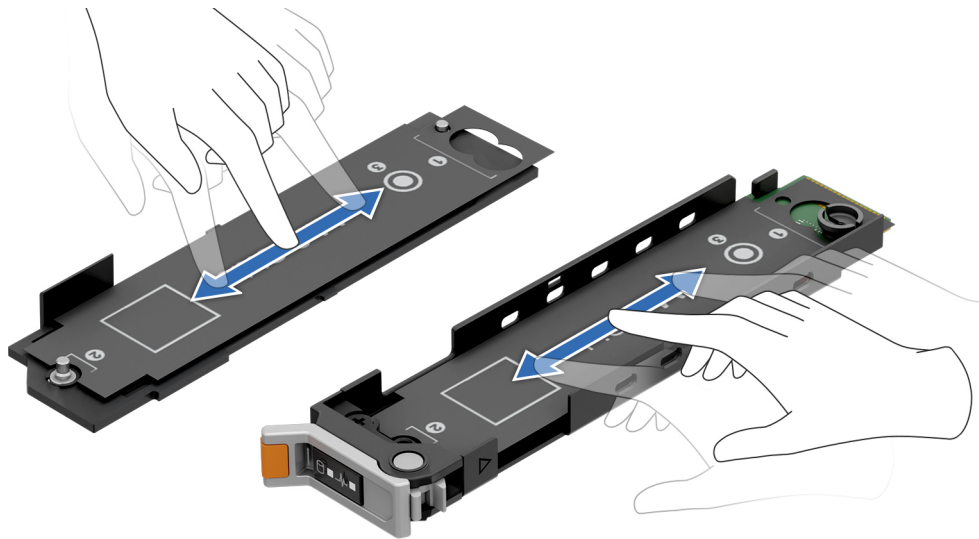

Figure 177. Pasting the new thermal pads

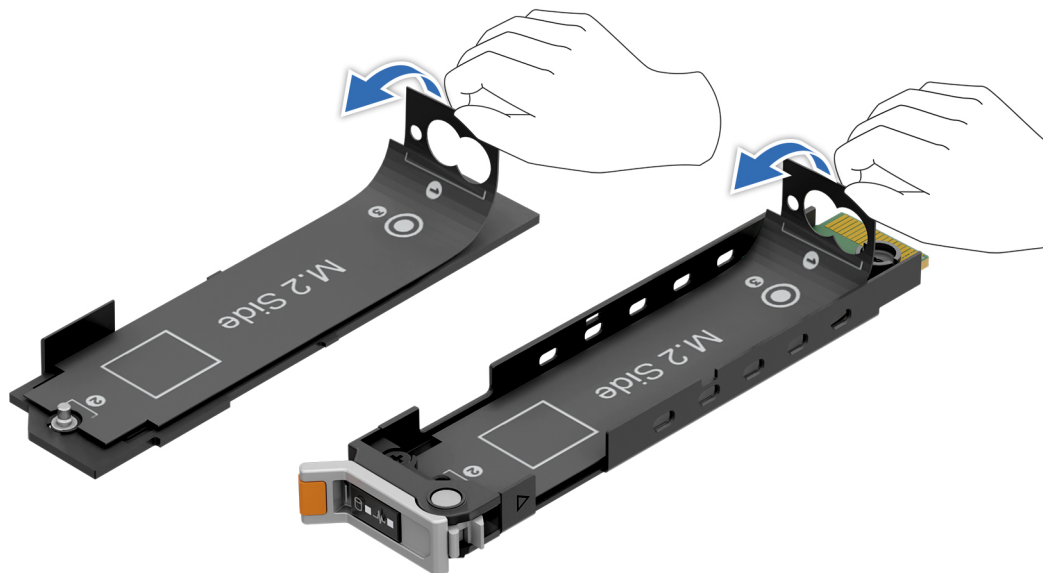
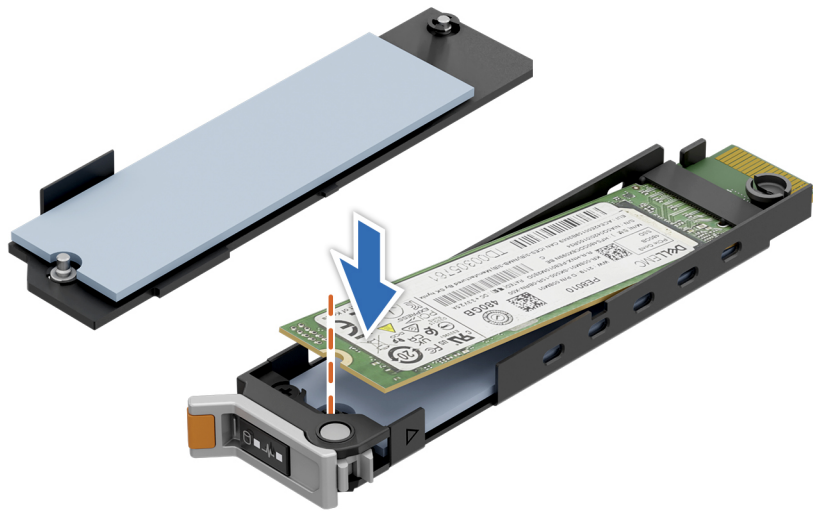

Figure 178. Removing the black mylars

2. Align the M.2 NVMe SSD module at an angle with the BOSS-N1 DC-MHS card carrier connector.
3. Insert the M.2 NVMe SSD module until it is firmly seated in the BOSS-N1 DC-MHS card carrier connector.

**NOTE:** Press the M.2 NVMe SSD card until it adheres to the thermal pad.

Figure 179. Installing the M.2 NVMe SSD



module

4. Align at an angle, place the top cover hook into the slot on the bottom cover of the BOSS-N1 DC-MHS card carrier.
5. Press the opposite side of the top cover until firmly seated.

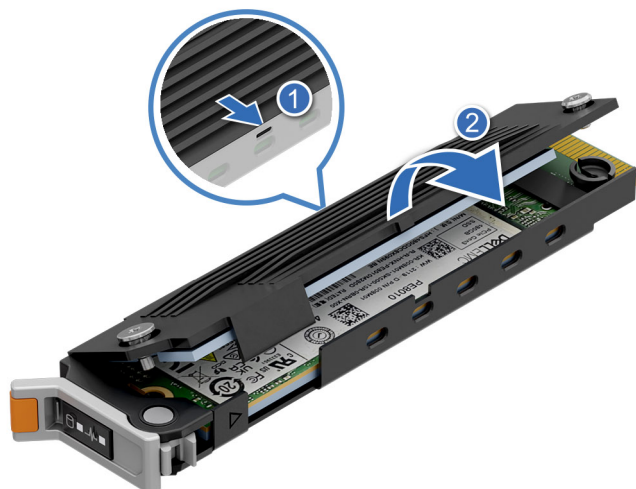

Figure 180. Installing the top cover

6. Using the Phillips 1 screwdriver, tighten the captive screws on the BOSS-N1 DC-MHS card carrier top cover.  
**NOTE:** Follow the sequence to tighten the captive screws. First, tighten the screw available at the front handle end, and then the screw at the connector end.



**Figure 181. Tighten the top cover captive screws**

7. Slide the BOSS-N1 DC-MHS card carrier into the BOSS-N1 module slot.
8. Close the BOSS-N1 DC-MHS card carrier release latch to lock the carrier in place.



**Figure 182. Installing the BOSS-N1 DC-MHS card carrier**

## Removing the M.2 NVMe SSD module from the M.2 Interposer board

### Prerequisites

1. Follow the safety guidelines listed in the [Safety instructions](#).
2. Follow the procedure listed in [Before working inside your system](#).
3. [Remove the M.2 Interposer board](#) .

### Steps

1. Using the Phillips 1 screwdriver, loosen the captive screws securing the top cover of the M.2 Interposer board. Tilt the top cover from the side and lift the top cover out of the M.2 Interposer board.

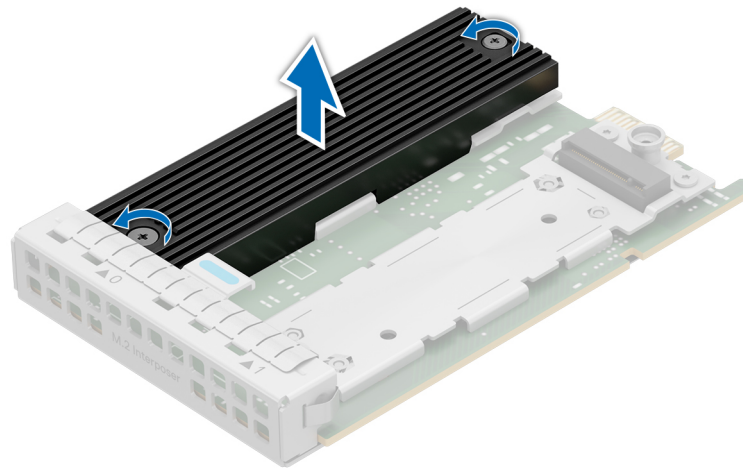

**Figure 183. Loosen the top cover captive screws**

2. Lift the M.2 NVMe SSD module to disconnect from the M.2 Interposer board.

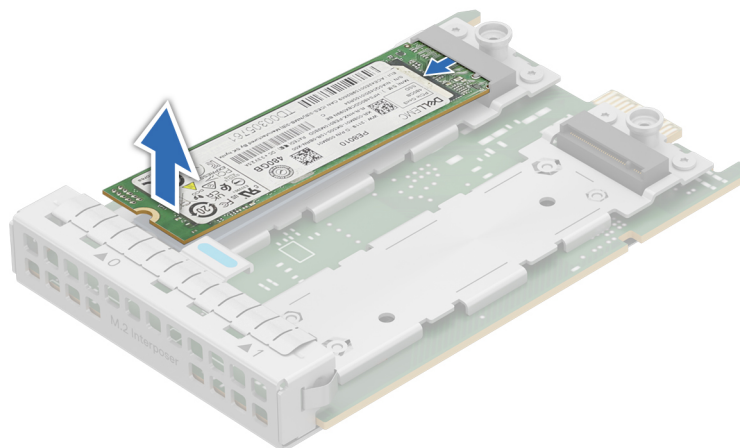

**Figure 184. Removing the M.2 NVMe SSD from the board**

#### Next steps

1. Replace the M.2 NVMe SSD module in the M.2 Interposer board.

## Installing the M.2 NVMe SSD module in the M.2 Interposer board

#### Prerequisites

1. Follow the safety guidelines listed in the [Safety instructions](#).
2. Follow the procedure listed in [Before working inside your system](#).
3. [Remove the M.2 Interposer board](#) .

#### Steps

1. Remove the thermal pads on the top cover and bottom cover of the the M.2 Interposer board, when replacing the M.2 NVMe SSD module in the M.2 Interposer board.

**NOTE:** The thermal pad that has been removed cannot be reused for installing the M.2 NVMe SSD module. You must use new thermal pads for the installation.

**NOTE:** The procedure to install the M.2 NVMe SSD module on slot0 and slot1 is same.

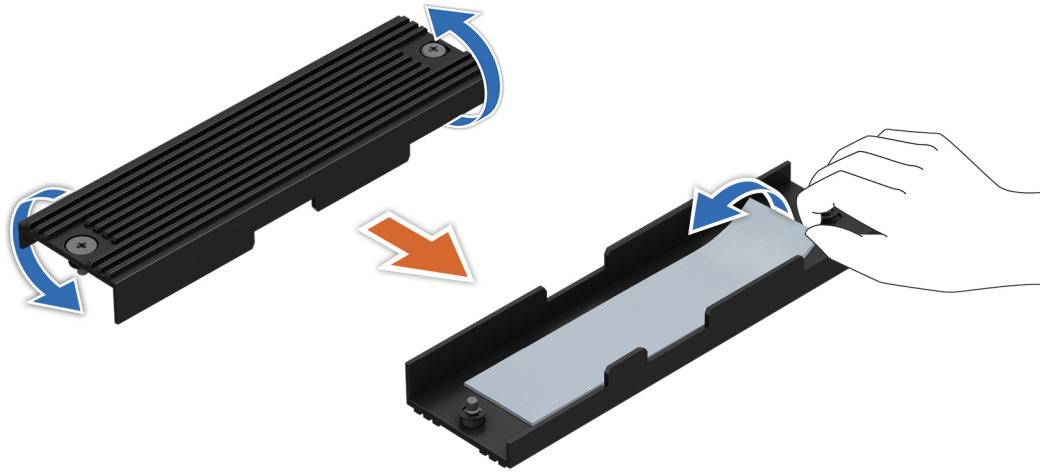

Figure 185. Removing the thermal pad from the top cover

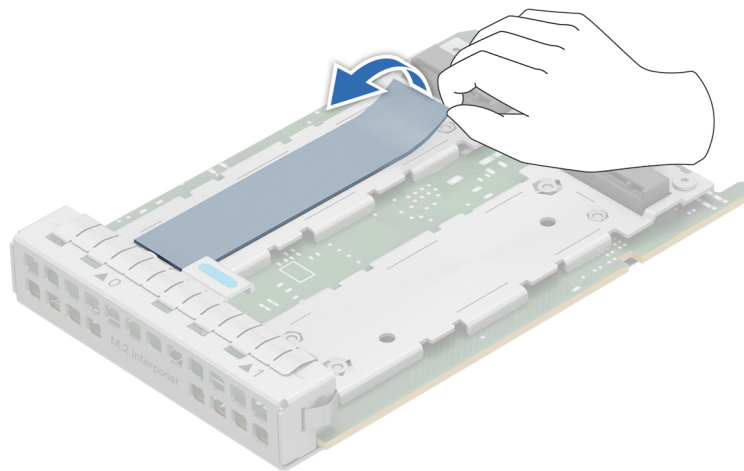

Figure 186. Removing the thermal pad from the board from the slot0

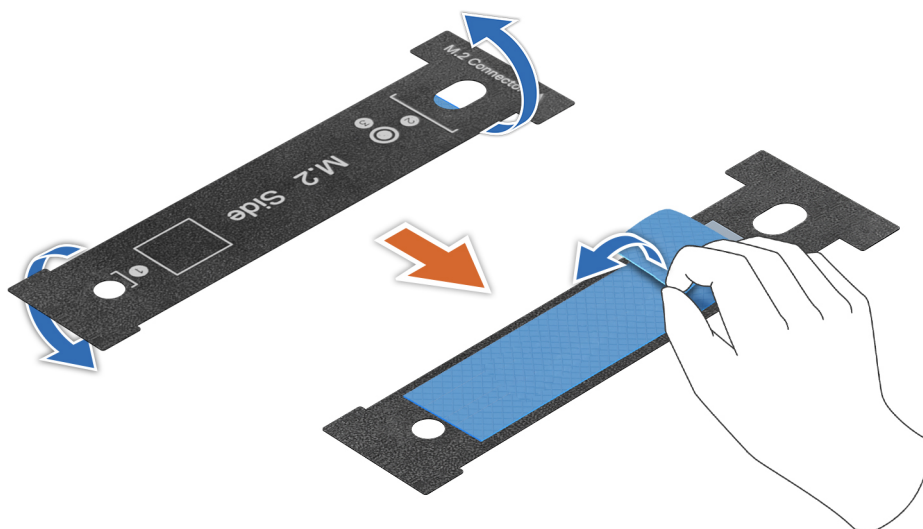
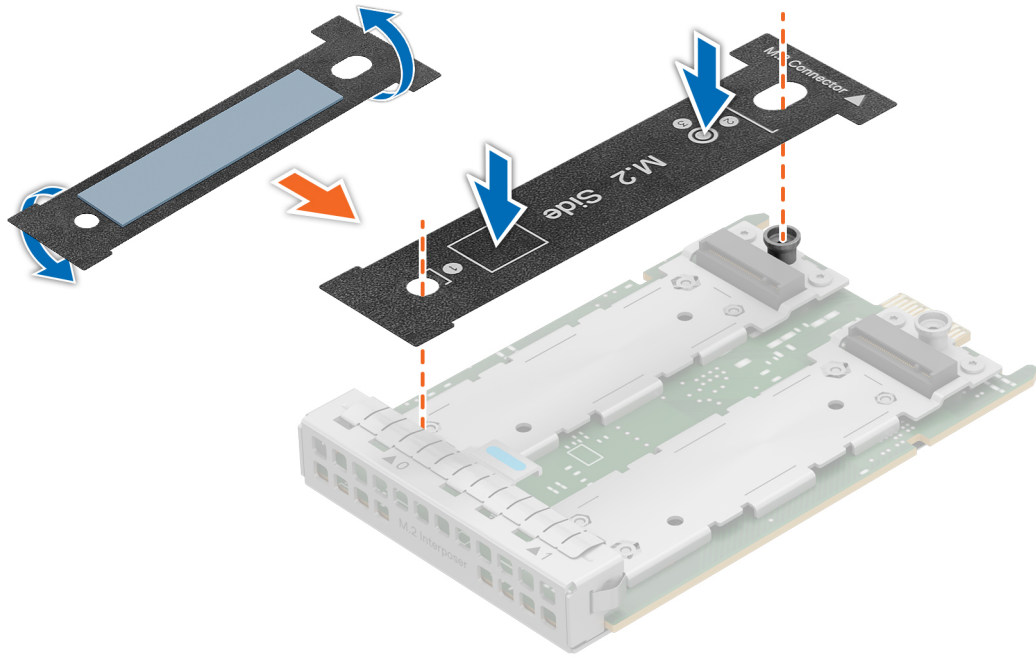
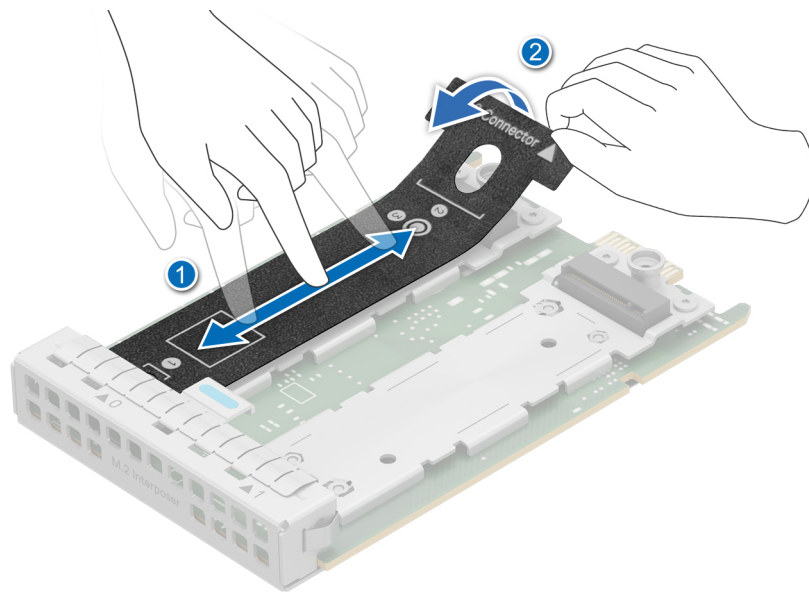

Figure 187. Removing the blue film from the new thermal pad



**Figure 188. Flipping and installing the new thermal pad on the board**



**Figure 189. Pasting the new thermal pad on the board and removing the black mylar**

2. Align the M.2 NVMe SSD module at an angle with the M.2 Interposer board.
3. Insert the M.2 NVMe SSD module until it is firmly seated in the M.2 Interposer board.

**NOTE:** Press the M.2 NVMe SSD module until it adheres to the thermal pad.

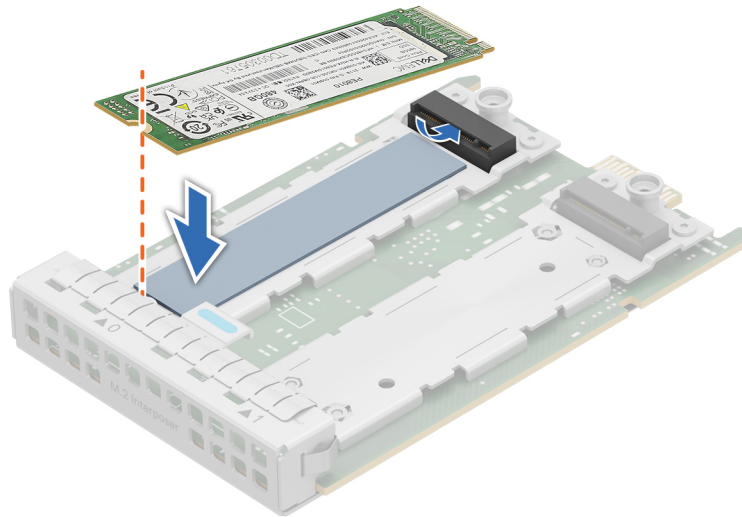

Figure 190. Installing the new M.2 NVMe SSD module

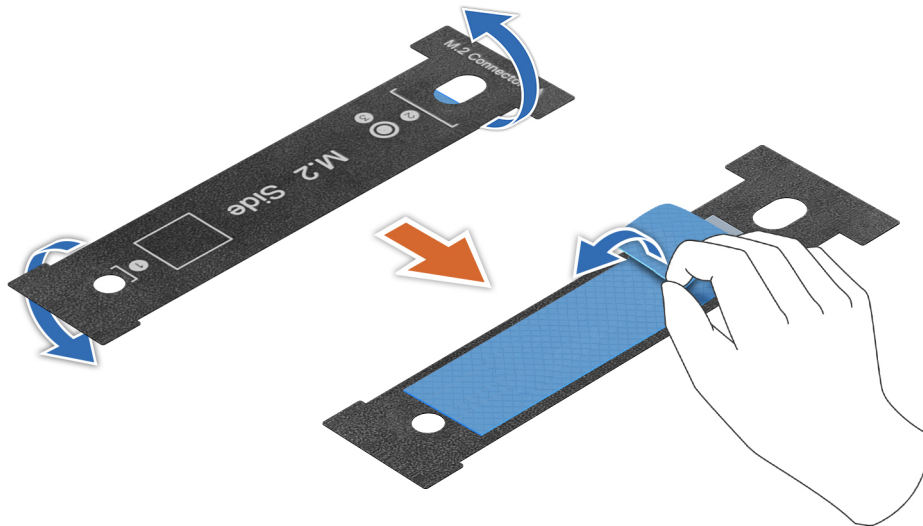
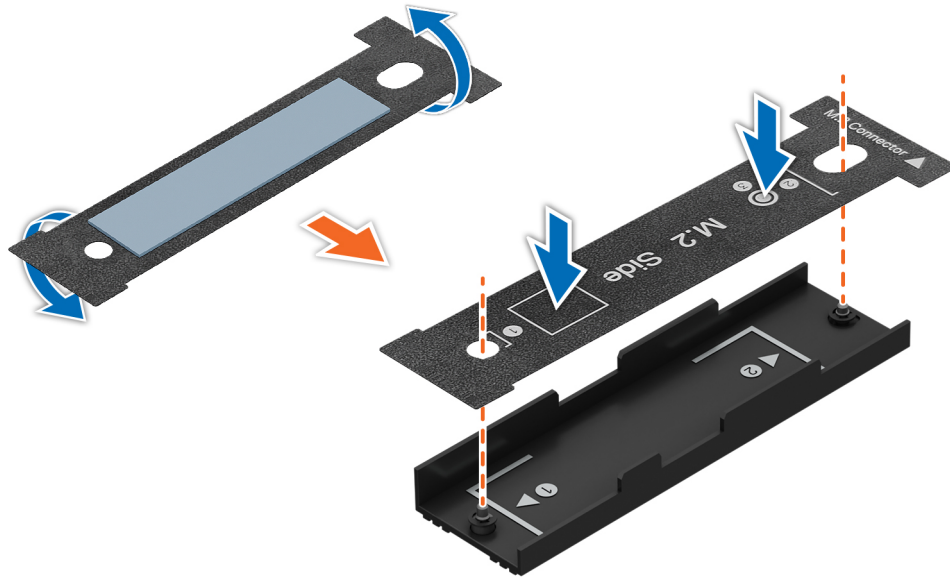
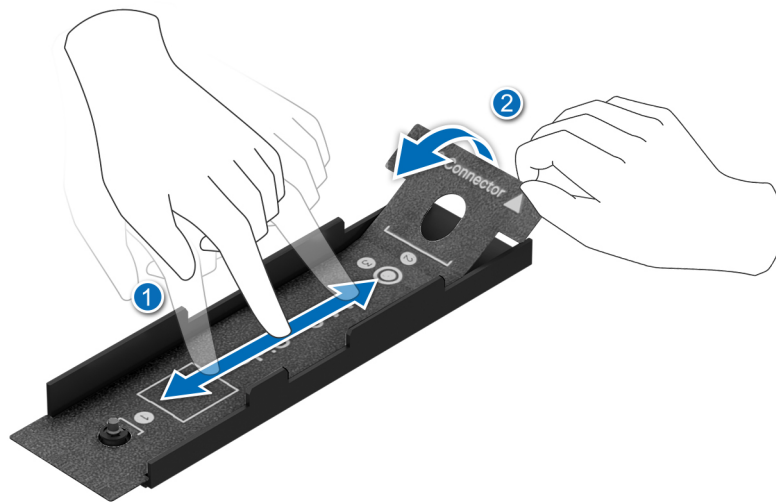

Figure 191. Removing the blue film from another thermal pad



**Figure 192. Installing the new thermal pad inside the top cover**



**Figure 193. Pasting the new thermal pad inside the top cover and removing the black mylar from the thermal pad**

4. Flip the top cover and install it on the M.2 Interposer board. Using the Phillips 1 screwdriver, tighten the captive screws on the M.2 Interposer board top cover.

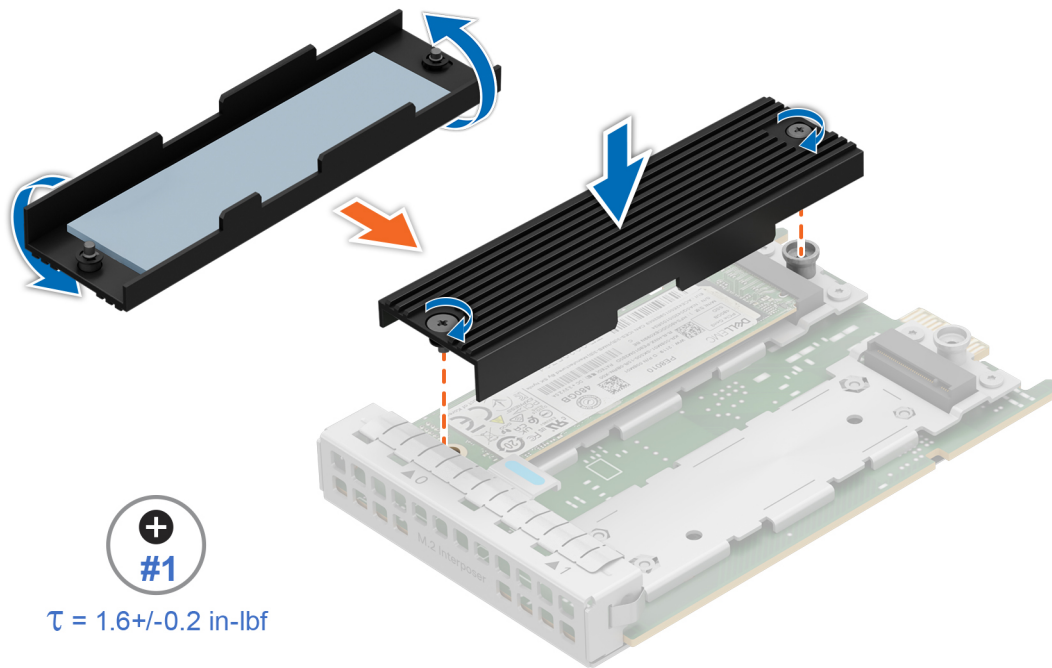

Figure 194. Installing the top cover

## Optional BOSS-N1 DC-MHS module

This is a service technician replaceable part only.

### Removing the front BOSS-N1 DC-MHS module

#### Prerequisites

1. Follow the safety guidelines listed in the [Safety instructions](#).
2. Follow the procedure listed in the [Before working inside your system](#).
3. [Remove the cooling fans](#).
4. [Remove the drive backplane cover](#).
5. Disconnect the cables from the system board, observe the cable routing.

**(i) NOTE:** See [cable routing](#) section for more information.

#### Steps

1. Lift the plunger and slide the BOSS-N1 DC-MHS module tray out of the system.

**(i) NOTE:** The numbers on the image do not depict the exact steps. The numbers are for representation of sequence.



**Figure 195. Removing a BOSS-N1 DC-MHS module tray from the system**

2. Press both ends of the cable holder and tilt the BOSS-N1 DC-MHS module cable holder. Disconnect the cable from the BOSS module.

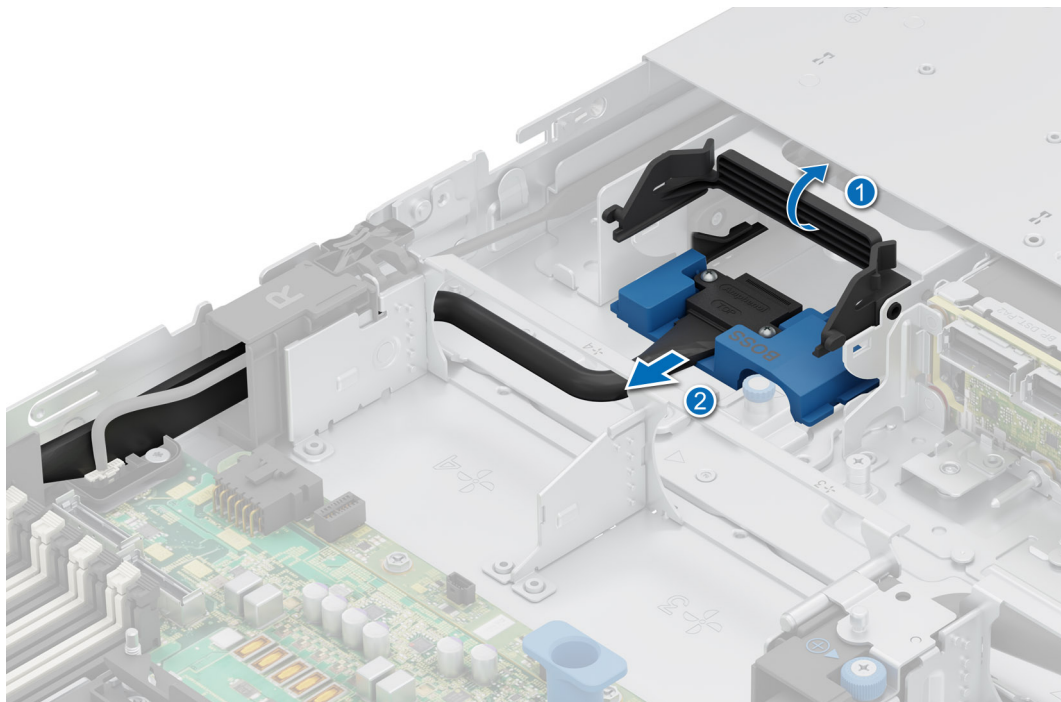

**Figure 196. Removing a BOSS-N1 DC-MHS cable from the system**

3. Disconnect the BOSS cable connector from the connectors on the system board.
4. Push the clips outward and slide out the BOSS-N1 DC-MHS module from the tray.

**NOTE:** For easier uninstallation, flip the entire module upside down to access both side clips.

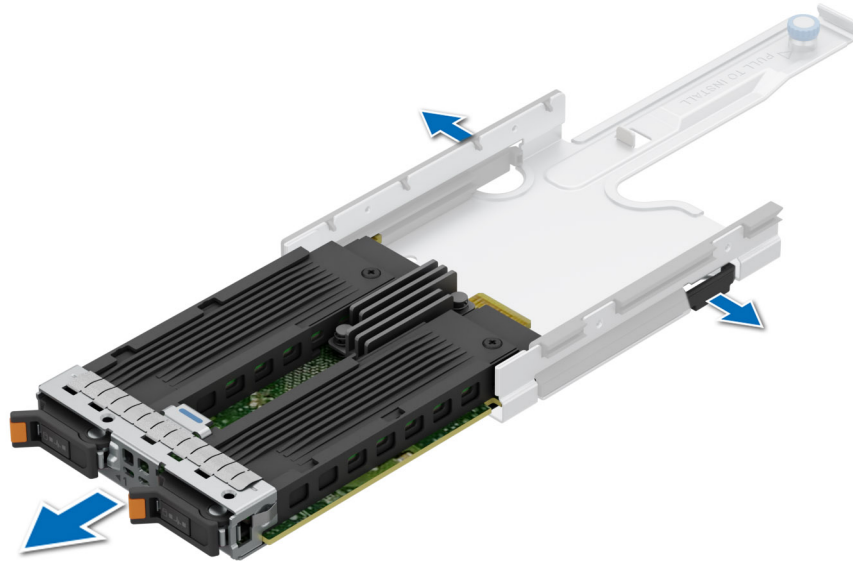

**Figure 197. Removing an BOSS-N1 DC-MHS module from tray**

5. If the BOSS-N1 DC-MHS module is not going to be replaced, install a filler.

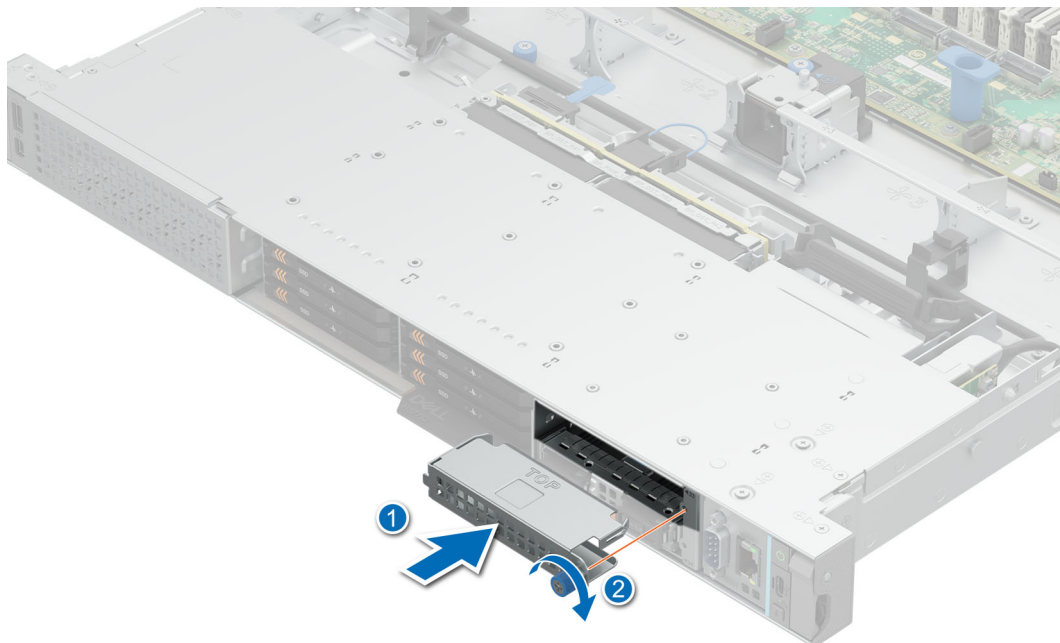

**Figure 198. Installing an BOSS-N1 DC-MHS module filler bracket**

#### **Next steps**

Replace the front BOSS-N1 DC-MHS module .

# Installing the front BOSS-N1 DC-MHS module

## Prerequisites

1. Follow the safety guidelines listed in the [Safety instructions](#).
2. Follow the procedure listed in [Before working inside your system](#).
3. [Remove the cooling fans](#).
4. [Remove the drive backplane cover](#).
5. Route and connect the cables, taking care not to damage them.

**NOTE:** See [cable routing](#) section.

**CAUTION:** Do not install GPUs, network cards, or other PCIe devices on your system that are not validated and tested by Dell. Damage caused by unauthorized and invalidated hardware installation will null and void the system warranty.

## Steps

1. If installed, remove the filler bracket.

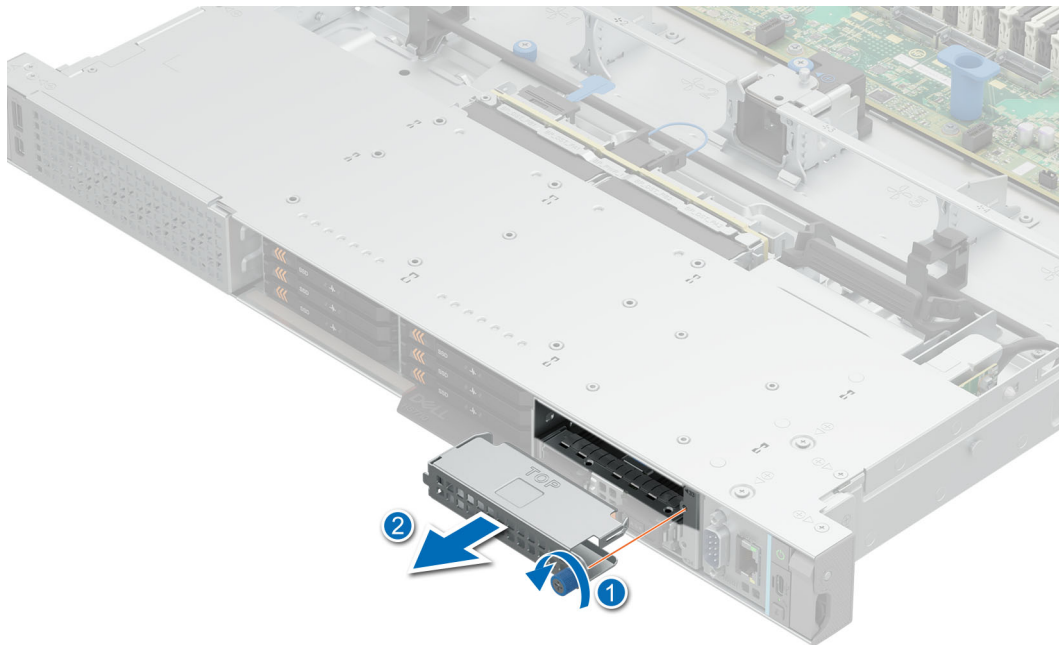

**Figure 199. Removing an BOSS-N1 DC-MHS module filler bracket**

2. Align and slide the BOSS-N1 DC-MHS module into the tray until it is firmly seated.

**NOTE:** Make sure that the metallic tray is in unlock position before sliding the BOSS module into the tray.

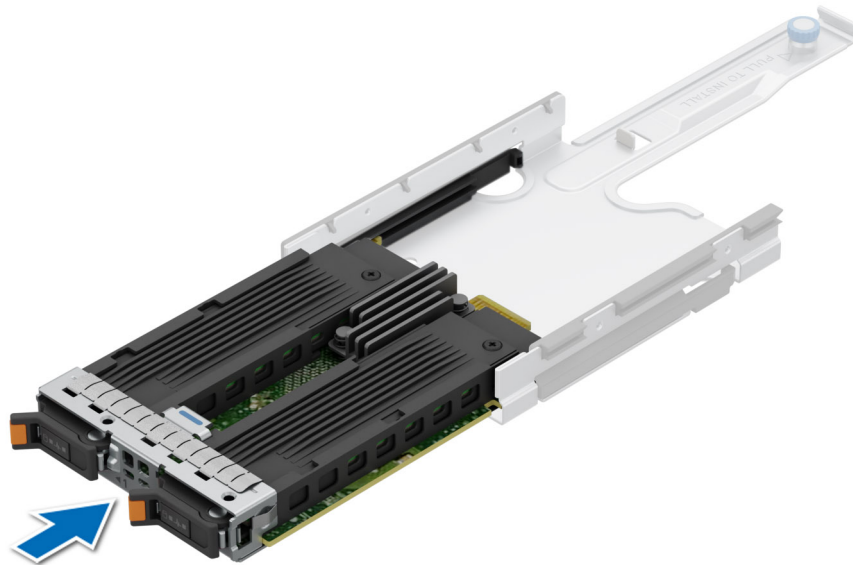

**Figure 200. Installing the BOSS-N1 DC-MHS module into the tray**

3. Align and slide the BOSS-N1 DC-MHS module tray into the system until the plunger presses the stop point.
4. Reconnect the BOSS module cable connector on the system board on one side and reconnect the another side cable to the connector on the BOSS module cable. Tilt the cable holder to secure the BOSS-N1 DC-MHS module cable into the system.

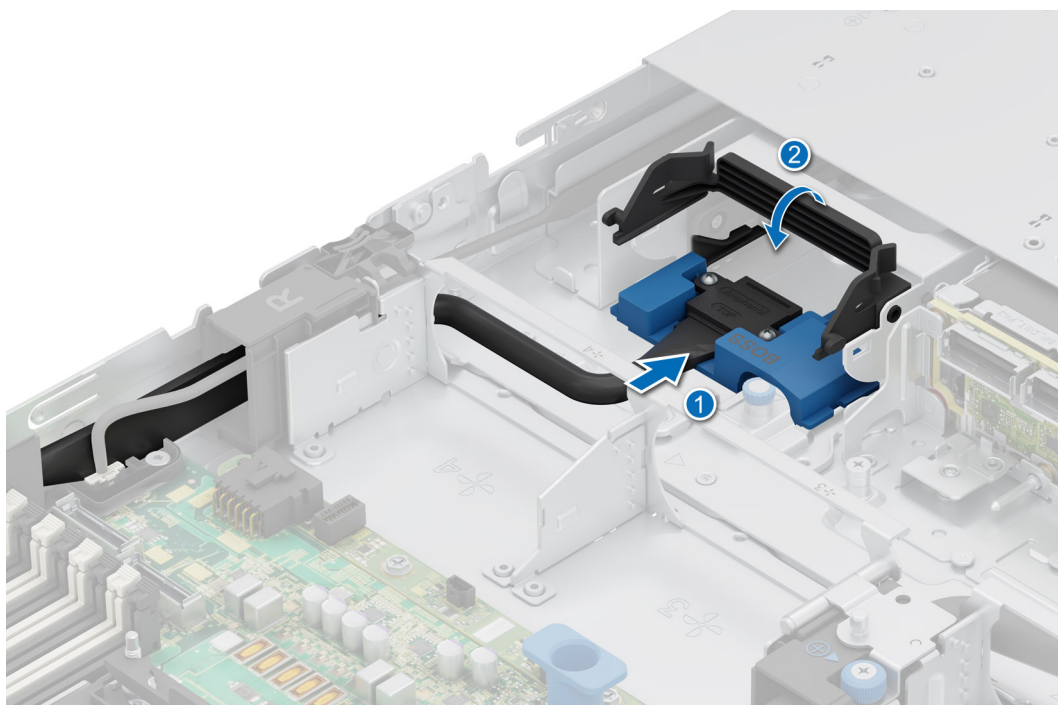

**Figure 201. Reconnecting the cable connectors**

5. Pull up and slide the plunger to secure it in the hole on the system.

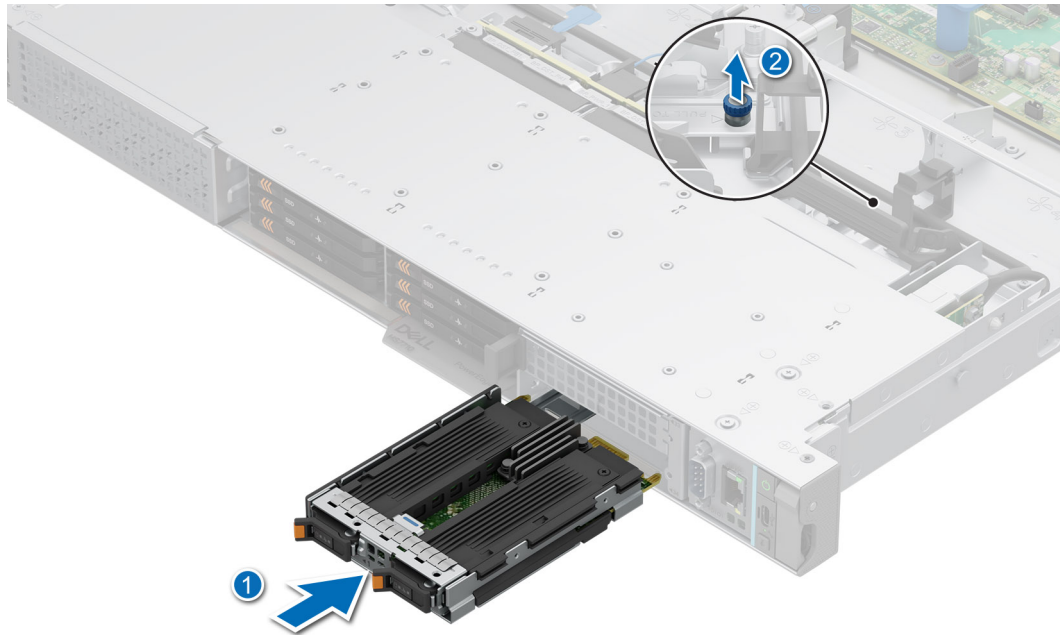

**Figure 202. Installing the BOSS-N1 DC-MHS module tray into system**

#### Next steps

1. Route and connect the cables, taking care not to damage them.

**NOTE:** See [cable routing](#) section for more information.

2. [Install the M.2 NVMe SSD module](#)
3. [Install the drive backplane cover](#).
4. [Install the cooling fans](#).
5. Follow the procedure listed in the [After working inside your system](#).

## Removing the rear BOSS-N1 DC-MHS module

#### Prerequisites

1. Follow the safety guidelines listed in the [Safety instructions](#).
2. Follow the procedure listed in [Before working inside your system](#).
3. [Remove the rear expansion card riser](#) or [remove the rear expansion card riser blanks](#)
4. [Remove the M.2 NVMe SSD module](#).

#### Steps

1. Open the blue latch to disengage the BOSS-N1 DC-MHS module.
2. Push the BOSS-N1 DC-MHS module towards the rear end of the system to disconnect from the connector on the system board.
3. Slide the BOSS-N1 DC-MHS module out of the slot on the system.

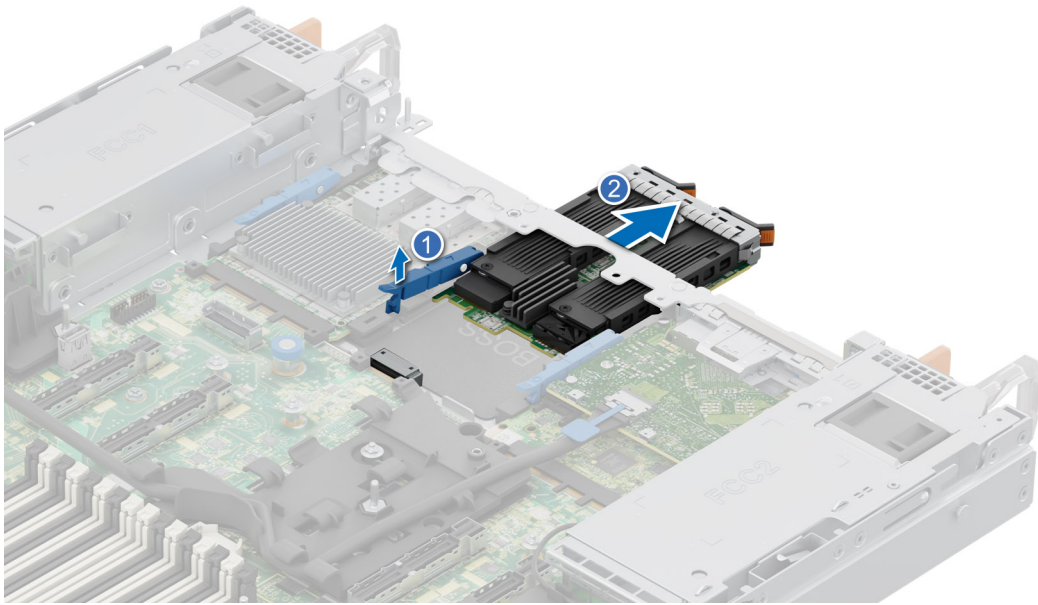

**Figure 203. Removing the rear BOSS-N1 DC-MHS**

4. If the BOSS-N1 DC-MHS module is not going to be replaced, install a filler bracket.

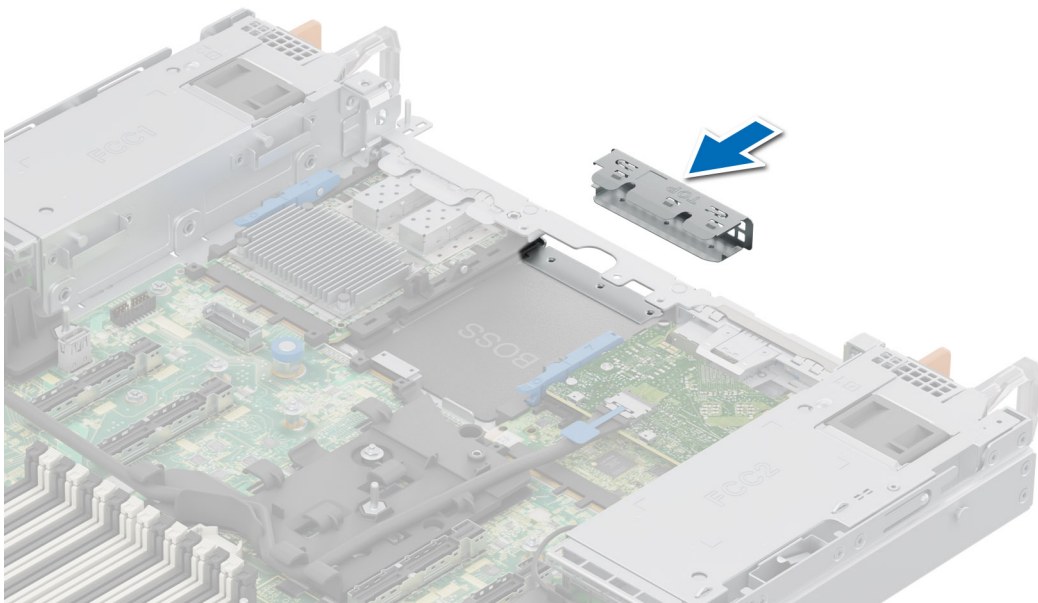

**Figure 204. Installation of filler bracket**

#### **Next steps**

1. [Replace the rear BOSS-N1 DC-MHS module.](#)

# Installing the rear BOSS-N1 DC-MHS module

## Prerequisites

1. Follow the safety guidelines listed in the [Safety instructions](#).
2. Follow the procedure listed in the [Before working inside your system](#).
3. [Remove the rear expansion card riser](#) or [remove the rear expansion card riser blanks](#)
4. [Remove the M.2 NVMe SSD module](#).

## Steps

1. If installed, remove the filler bracket.

**i** **NOTE:** Store the filler bracket for future use. Filler brackets must be installed in empty expansion card slots to maintain Federal Communications Commission (FCC) certification of the system. The brackets also keep dust and dirt out of the system and aid in proper cooling and airflow inside the system.

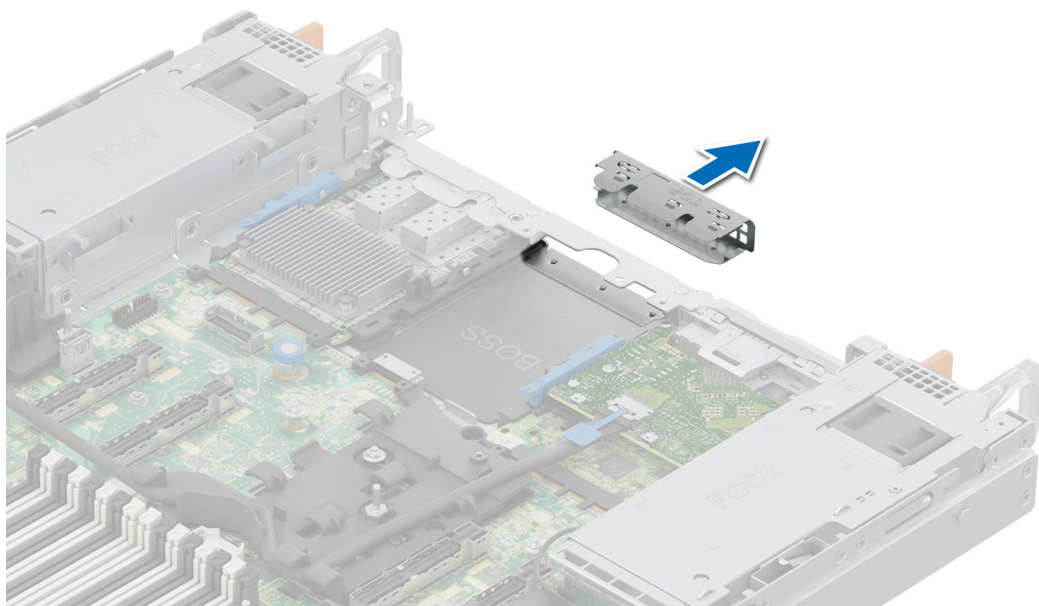

**Figure 205. Removal of filler bracket**

2. Open the blue latch on the system board.
3. Slide the BOSS-N1 DC-MHS module into the slot in the system.
4. Push until the BOSS-N1 DC-MHS module is connected to the connector on the system board.
5. Close the blue latch to lock the BOSS-N1 DC-MHS module to the system.

**i** **NOTE:** The numbers on the image do not depict the exact steps. The numbers are for representation of sequence.

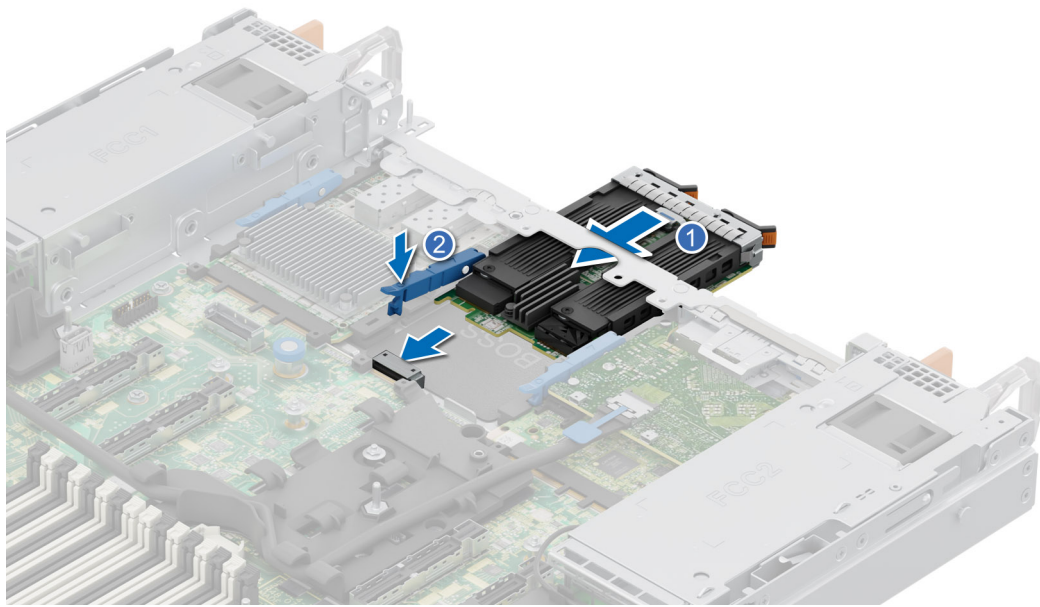

Figure 206. Installing the BOSS-N1 DC-MHS module

#### Next steps

1. Install the M.2 NVMe SSD module.
2. Install the rear expansion card riser or install the rear expansion card riser blanks
3. Follow the procedure listed in the *After working inside your system*.

## BOSS-N1 DC-MHS - Replacement instructions

To replace the BOSS-N1 DC-MHS, follow the steps as shown below:

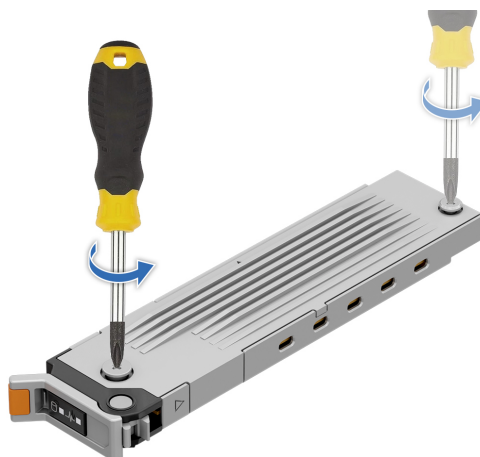

Figure 207. Loosen the top cover captive screw

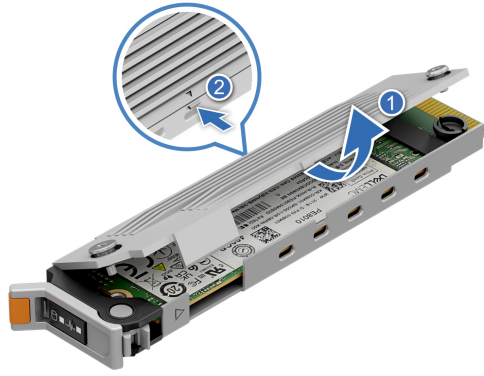

Figure 208. Removing the top cover

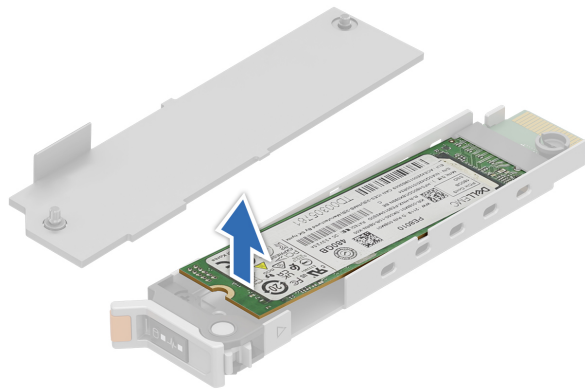

Figure 209. Removing the SSD module



Figure 210. Unboxing the new BOSS carrier

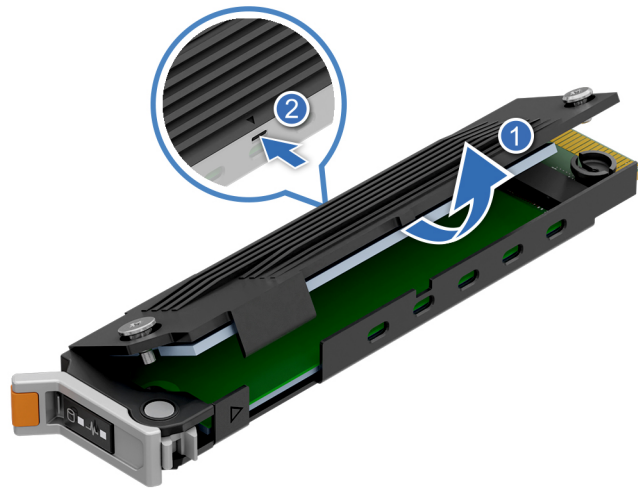

Figure 211. Removing the top cover

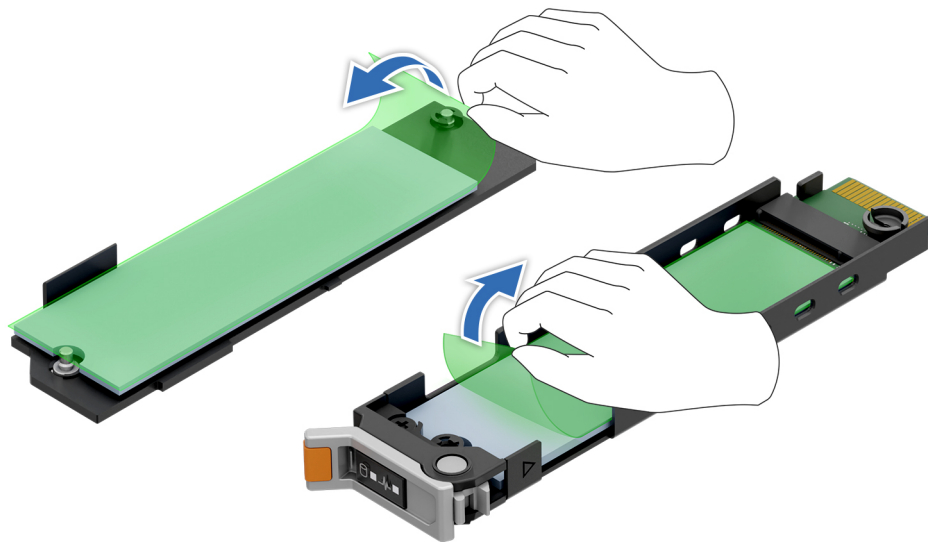

Figure 212. Removing the green films from the top cover and bottom cover

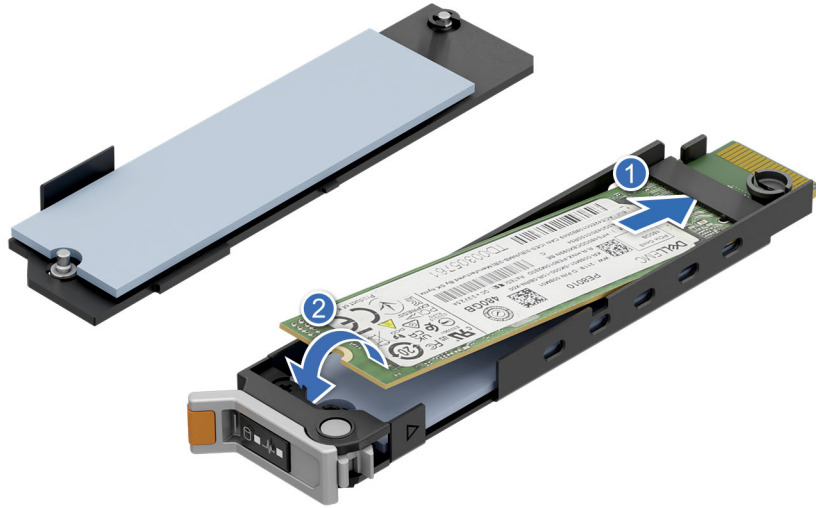

Figure 213. Installing the SSD module in the carrier

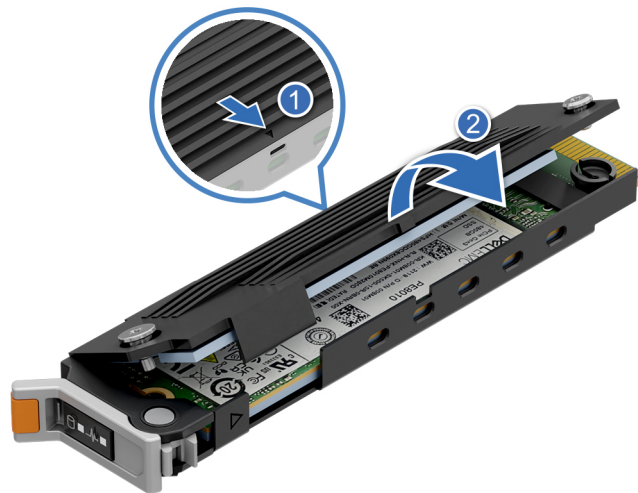

Figure 214. Installing the top cover

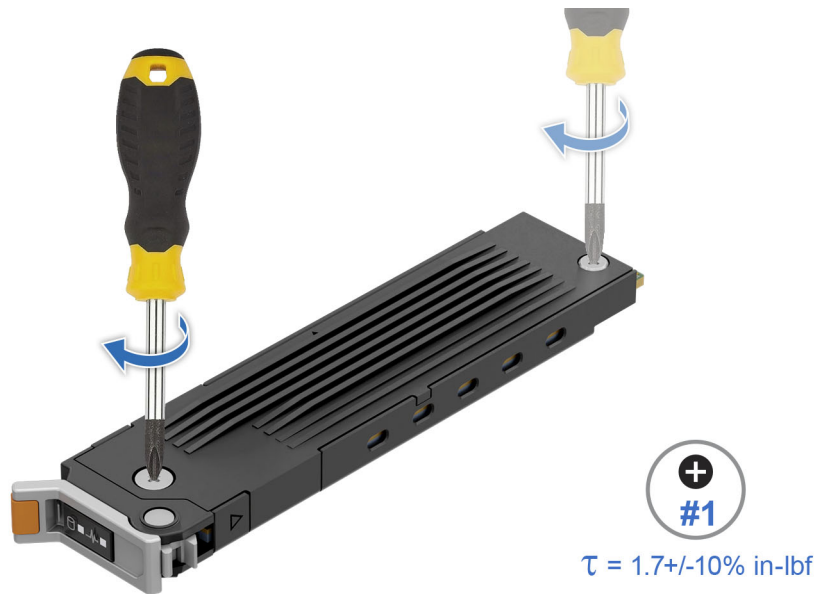

Figure 215. Tightening the top cover

## Optional M.2 Interposer board

This is a service technician replaceable part only.

**NOTE:** For information about M.2 Interposer board with Thermal pad replacement and M.2 NVMe SSD module installation, go to [PowerEdge Manuals](#) > **Rack Servers** > PowerEdge R670 > **Select This Product** > **Documentation** > **Manuals and Documents** > **M.2 Interposer board - Replacement and M.2 NVMe SSD module - Installation Tech Sheet**.

## Removing the M.2 Interposer board

### Prerequisites

1. Follow the safety guidelines listed in the [Safety instructions](#).
2. Follow the procedure listed in [Before working inside your system](#).
3. [Remove the rear expansion card riser](#) or [remove the rear expansion card riser blanks](#)

### Steps

1. Open the blue latch to disengage the M.2 Interposer board.
2. Press and hold the push point on the card to push the M.2 Interposer board towards the rear of the system, disconnecting it from the connector on the HPM board.
3. Slide the M.2 Interposer board out of the slot on the system.

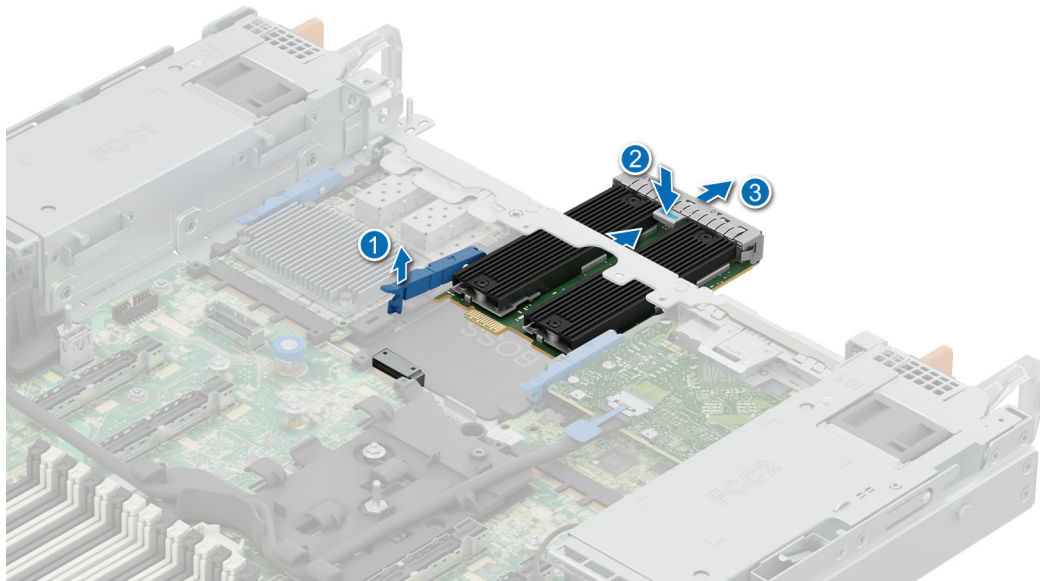

**Figure 216. Removing the M.2 Interposer board**

4. If the M.2 Interposer board is not going to be replaced, install a filler bracket.

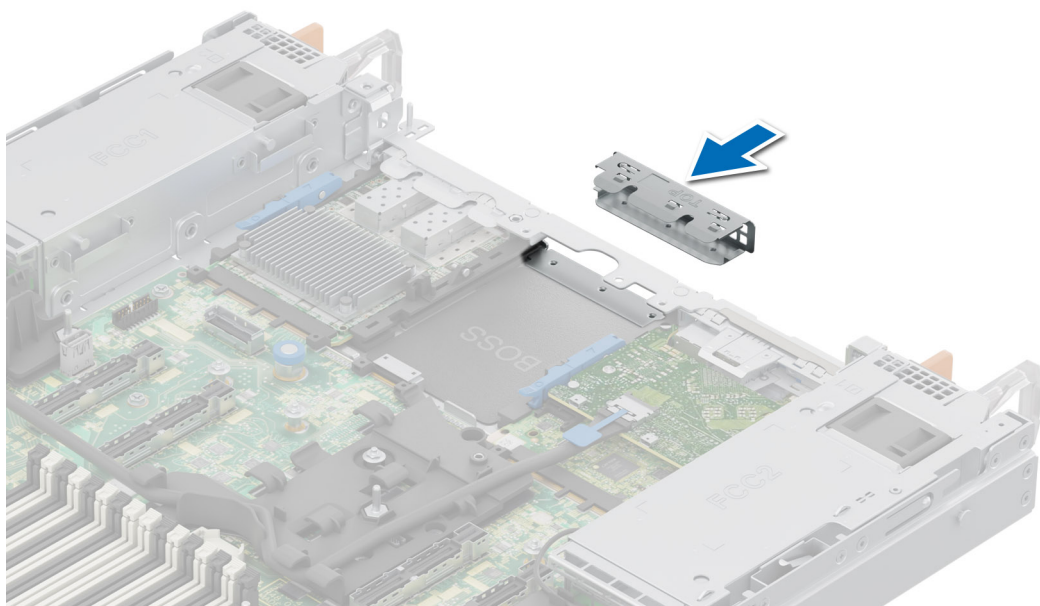

**Figure 217. Installation of filler bracket**

#### **Next steps**

1. Remove the M.2 NVMe SSD module from the M.2 Interposer board.

**i** **NOTE:** If a new M.2 Interposer board is being installed, the M.2 NVMe SSD modules must be removed from the existing M.2 Interposer board.

2. Replace the M.2 Interposer board.
3. Follow the procedure listed in the *After working inside your system*.

# Installing the M.2 Interposer board

## Prerequisites

1. Follow the safety guidelines listed in the [Safety instructions](#).
2. Follow the procedure listed in the [Before working inside your system](#).
3. [Remove the rear expansion card riser](#) or [remove the rear expansion card riser blanks](#)

## Steps

1. If installed, remove the filler bracket.

**i** **NOTE:** Store the filler bracket for future use. Filler brackets must be installed in empty expansion card slots to maintain Federal Communications Commission (FCC) certification of the system. The brackets also keep dust and dirt out of the system and aid in proper cooling and airflow inside the system.

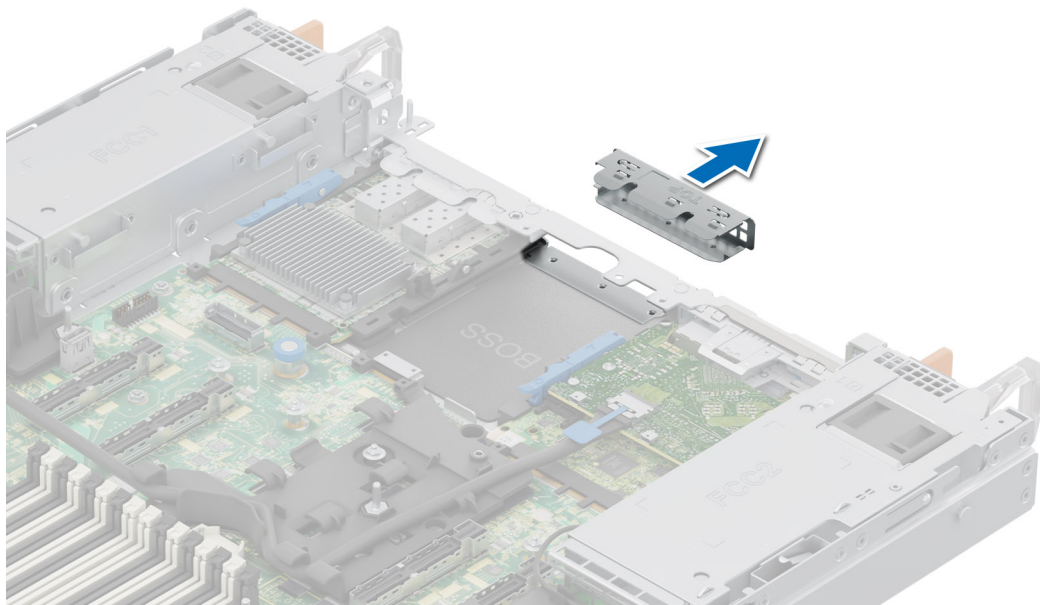

**Figure 218. Removal of filler bracket**

2. Remove the thermal pads from the top cover and from the bottom of the M.2 Interposer board, when replacing the M.2 Interposer board.

**⚠ CAUTION:** If you are not using the slot 1, peel off the protective film and the thermal pad on the slot 1.

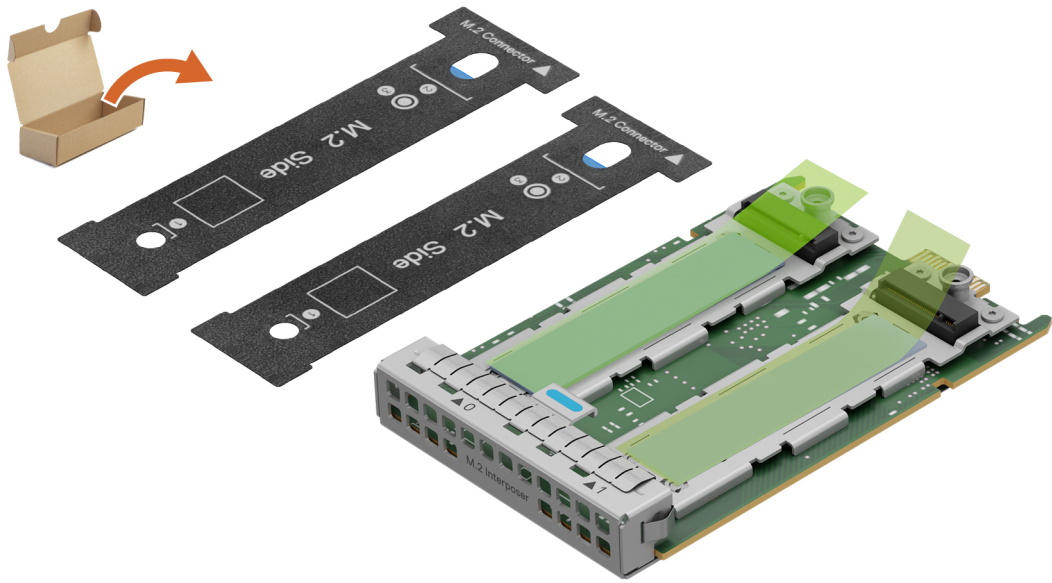

Figure 219. Kit contents

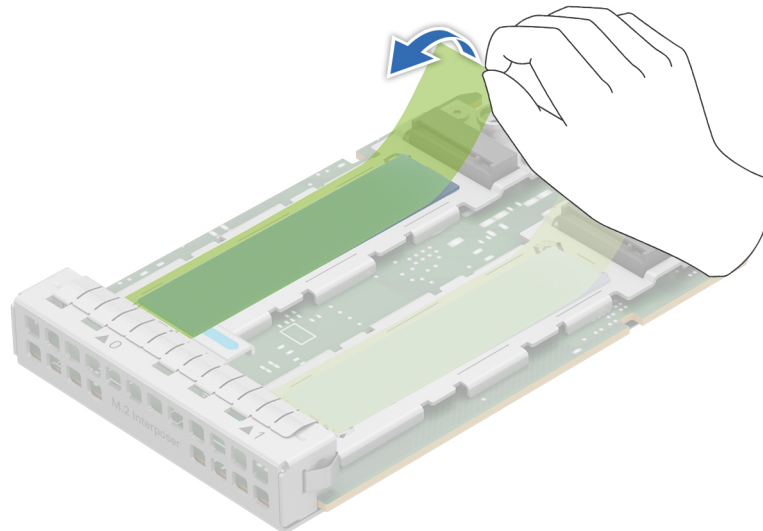

Figure 220. Removing the protective film from the thermal pad

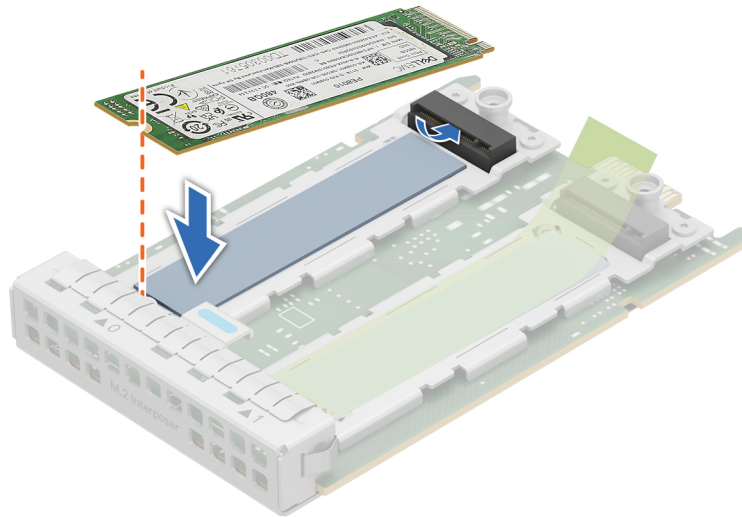

Figure 221. Installing the SSD

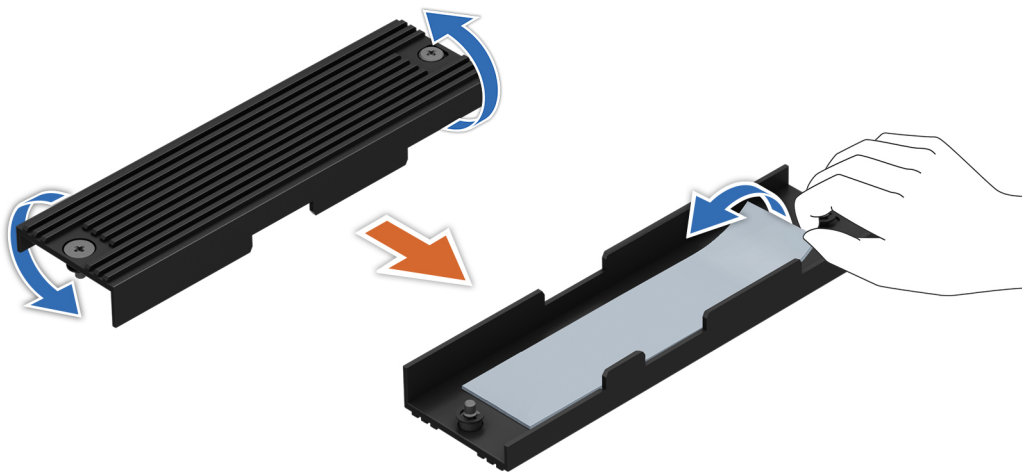

Figure 222. Flipping the top cover and removing the thermal pad from the top cover

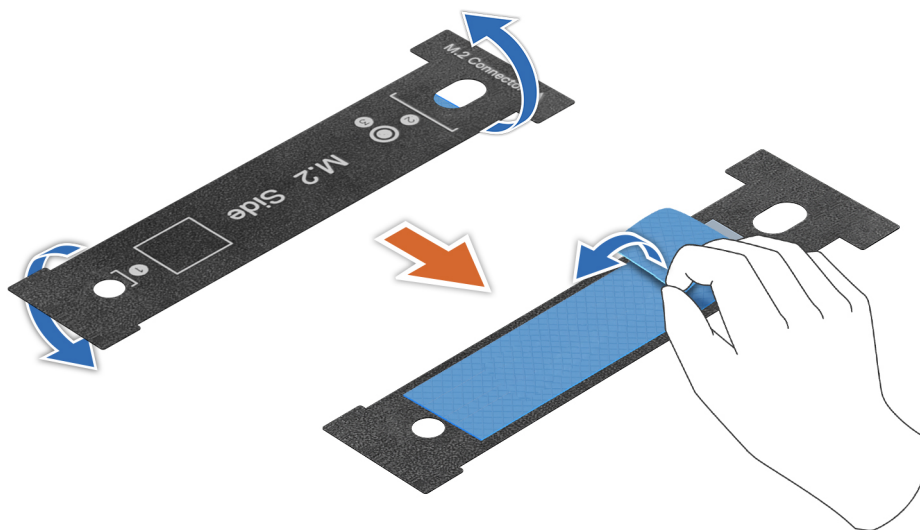

Figure 223. Removing the blue film from the new thermal pad

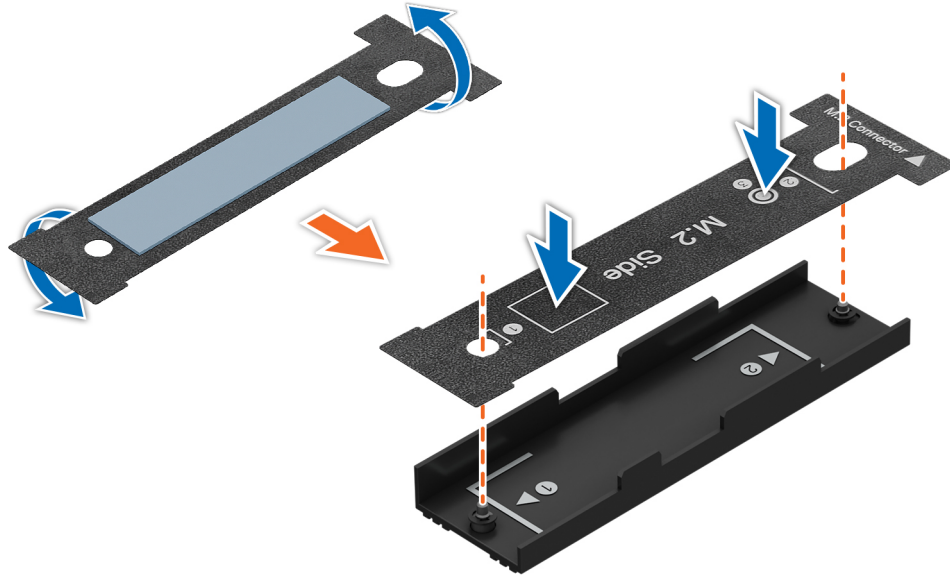

Figure 224. Installing the new thermal pad inside the top cover

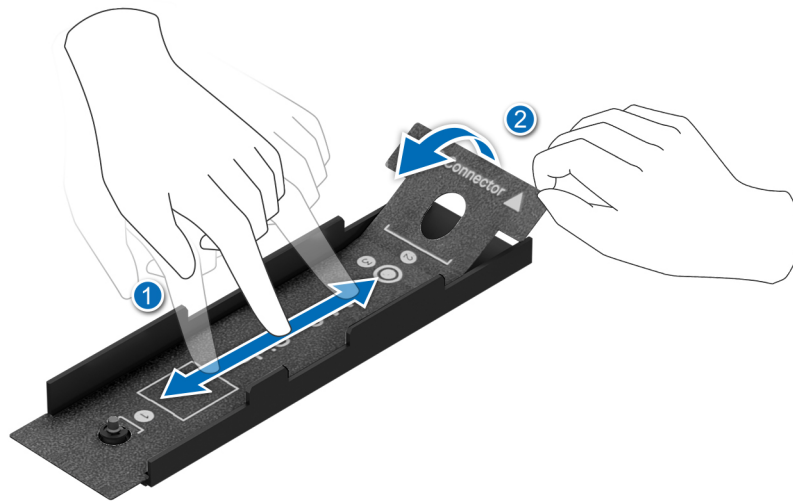
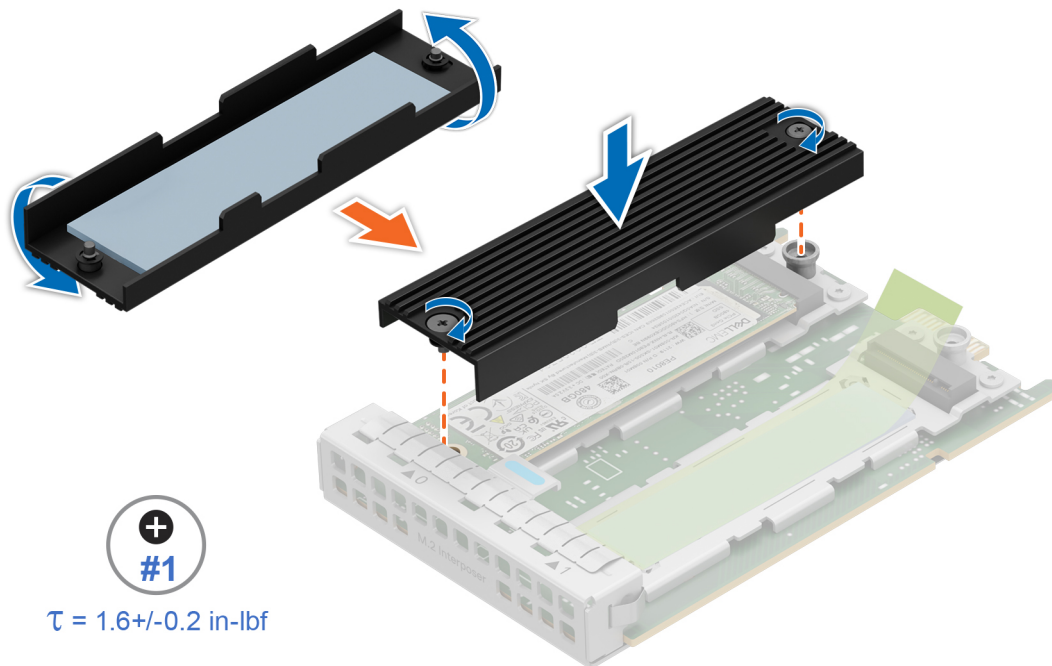

Figure 225. Pasting the new thermal pad inside the top cover and removing the black mylar



**Figure 226. Installing the top cover on the M.2 Interposer board**

3. Open the blue latch on the system board.
4. Slide the M.2 Interposer board into the slot in the system.
5. Push until the M.2 Interposer board is connected to the connector on the system board.
6. Open the blue latch on the system board.
7. Slide the M.2 Interposer board into the slot in the system.
8. Push until the M.2 Interposer board is connected to the connector on the system board.
9. Close the blue latch to lock the M.2 Interposer board to the system.

**NOTE:** The numbers on the image do not depict the exact steps. The numbers are for representation of sequence.

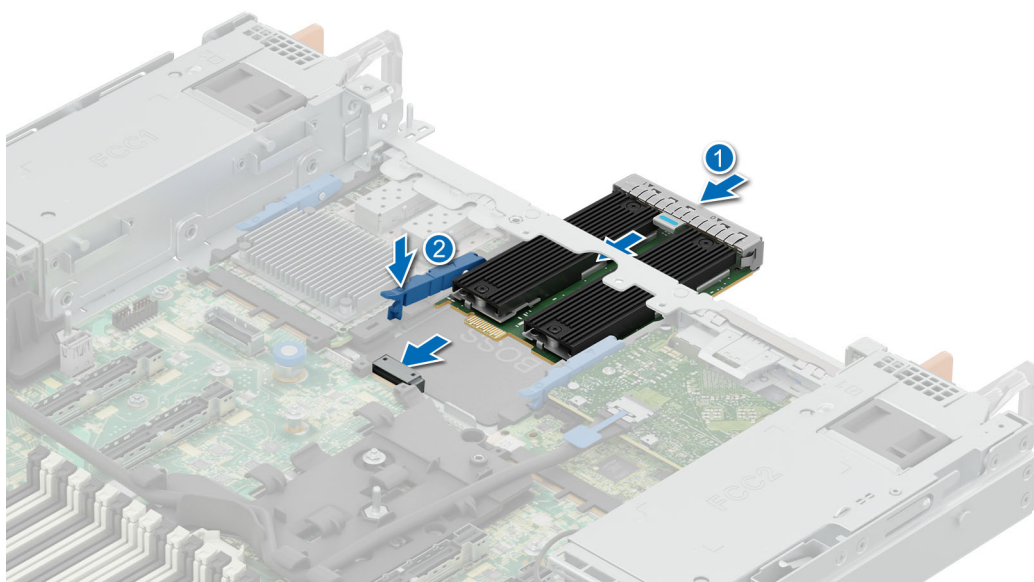

**Figure 227. Installing the M.2 Interposer board**

### Next steps

1. Install the rear expansion card riser or install the rear expansion card riser blanks
2. Follow the procedure listed in the [After working inside your system](#).

## Optional OCP NIC card

### Removing the front OCP NIC card

#### Prerequisites

1. Follow the safety guidelines listed in the [Safety instructions](#).
2. Follow the procedure listed in the [Before working inside your system](#).
3. [Remove the cooling fans](#).
4. [Remove the drive backplane cover](#).
5. Disconnect the cables from the system board, observe the cable routing.

**NOTE:** See [cable routing](#) section for more information.

#### Steps

1. Using the Phillips 2 screwdriver, loosen the captive screw on the OCP NIC card tray.
2. Pull and slide the OCP NIC card tray out from the OCP NIC cage.

**NOTE:** The numbers on the image do not depict the exact steps. The numbers are for representation of sequence.

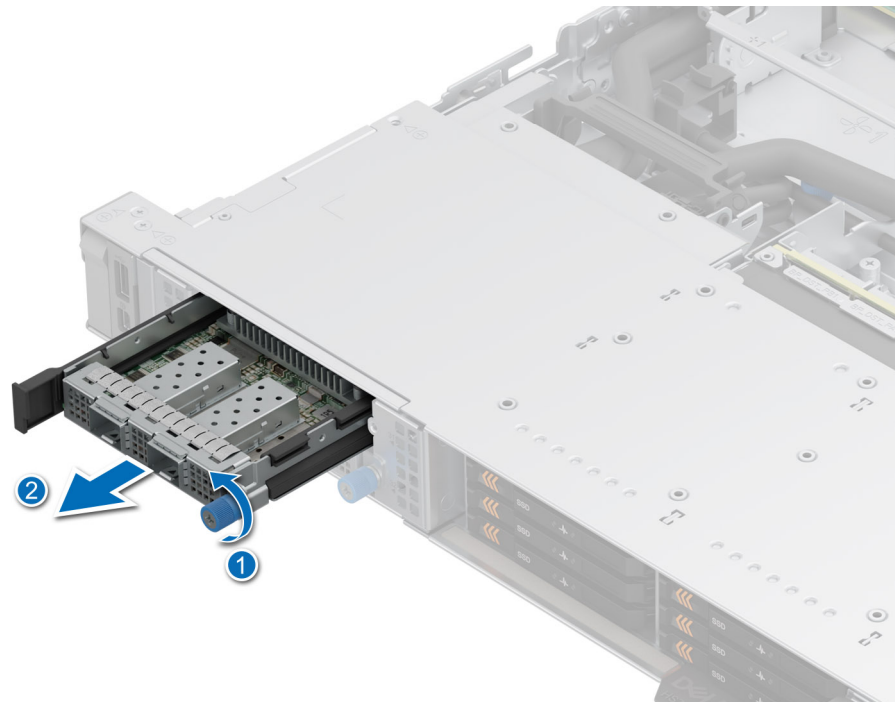

**Figure 228. Removing the OCP NIC card tray from the OCP NIC cage**

3. Push the clips outward, then pull and slide the OCP NIC card out from its tray.

**NOTE:** The numbers on the image do not depict the exact steps. The numbers are for representation of sequence.

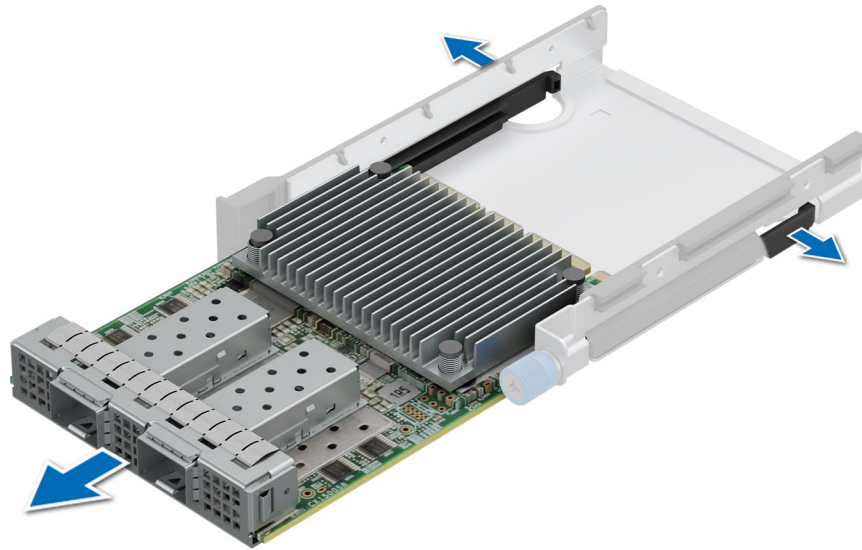

**Figure 229. Removing the OCP NIC card from the tray**

#### Next steps

Replace the front OCP NIC card.

## Installing the front OCP NIC card

#### Prerequisites

1. Follow the safety guidelines listed in the [Safety instructions](#).
2. Follow the procedure listed in [Before working inside your system](#).
3. [Remove the cooling fans](#).
4. [Remove the drive backplane cover](#).
5. [Install the front OCP cage](#).
6. Route and connect the cables, taking care not to damage them.

**NOTE:** See [cable routing](#) section for more information.

**CAUTION:** Do not install GPUs, network cards, or other PCIe devices on your system that are not validated and tested by Dell. Damage caused by unauthorized and invalidated hardware installation will null and void the system warranty.

#### Steps

1. Align and slide the OCP NIC card into the OCP NIC card tray

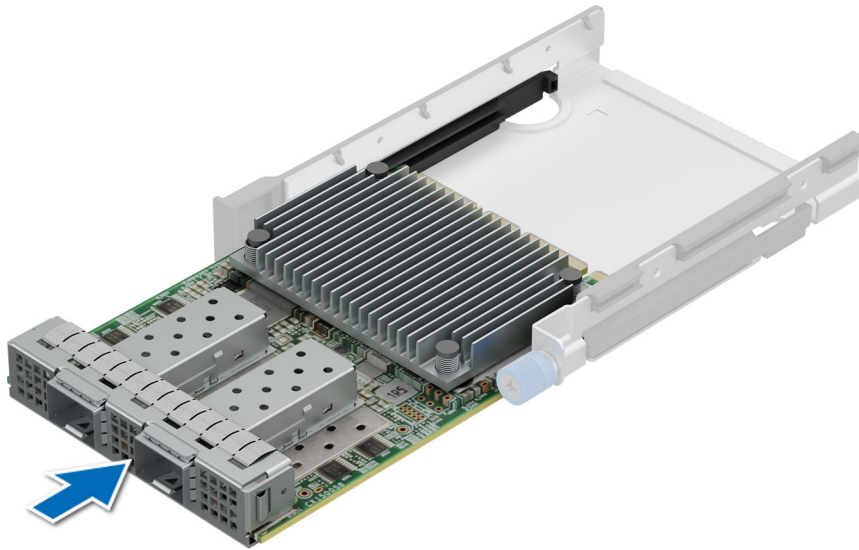

**Figure 230. Installing the OCP NIC card into the OCP NIC card tray**

2. Align and slide the OCP NIC card tray into the OCP NIC cage.
3. Using a Phillips 2 screwdriver, tighten the captive screw to secure the OCP NIC card tray in the cage.

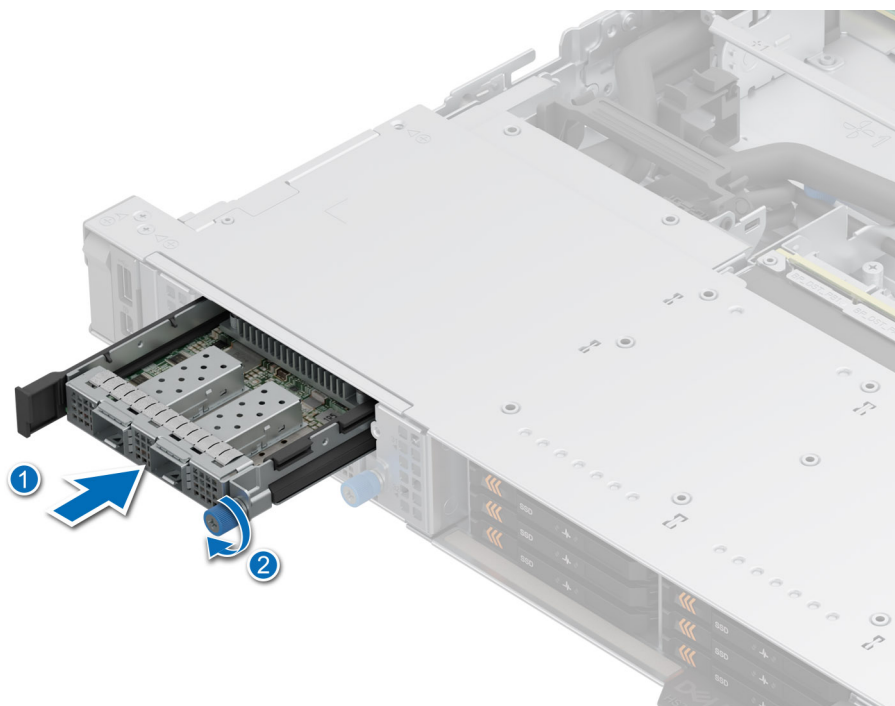

**Figure 231. Installing the OCP NIC tray into the OCP NIC cage**

#### **Next steps**

1. Route and connect the cables, taking care not to damage them.

**i** **NOTE:** See [cable routing](#) section for more information.

2. Install the drive backplane cover.

3. Install the cooling fans.
4. Follow the procedure listed in the [After working inside your system](#).

## Removing the front OCP NIC cage

### Prerequisites

1. Follow the safety guidelines listed in the [Safety instructions](#).
2. Follow the procedure listed in the [Before working inside your system](#).
3. [Remove the cooling fans](#).
4. [Remove the drive backplane cover](#).
5. [Remove the front OCP NIC card](#).
6. Disconnect the cables routing from the left side wall bracket and middle cable bracket from their connectors on the system board.

**NOTE:** See [cable routing](#) section for more information.

### Steps

1. Using the Phillips 2 screwdriver, loosen the thumb screw on the OCP NIC cage.
2. Pull and slide the OCP NIC cage out from the front of the system.

**NOTE:** The numbers on the image do not depict the exact steps. The numbers are for representation of sequence.

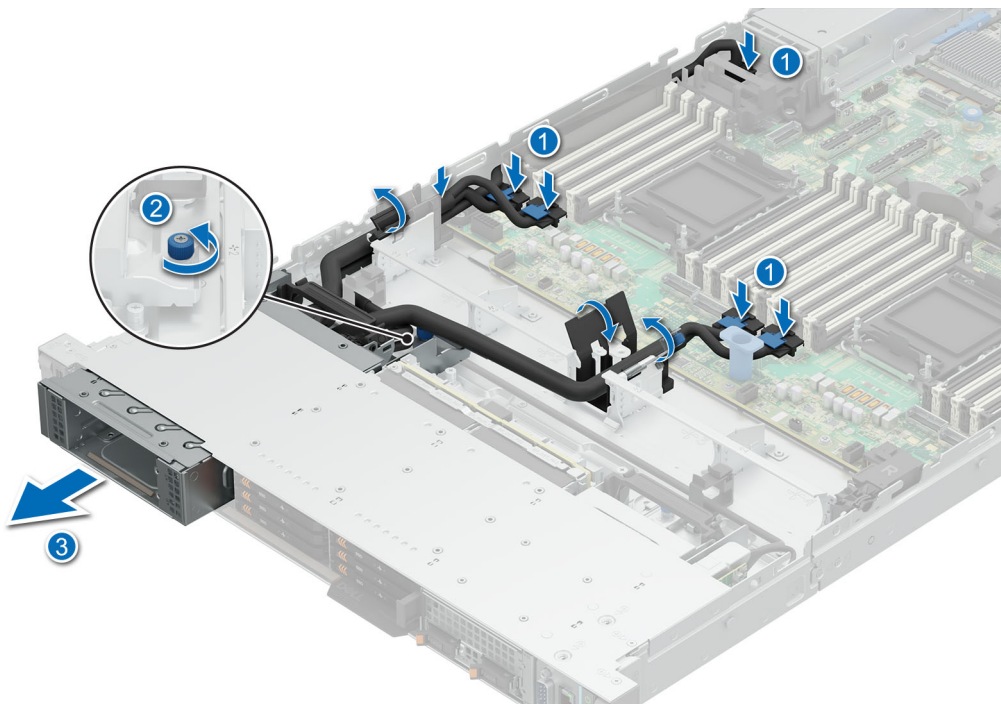

**Figure 232. Removing an OCP NIC cage from front of the system**

3. If the OCP NIC cage is not being replaced, install a filler tray into the system and secure it by tightening the captive screw using a Phillips 2 screwdriver.

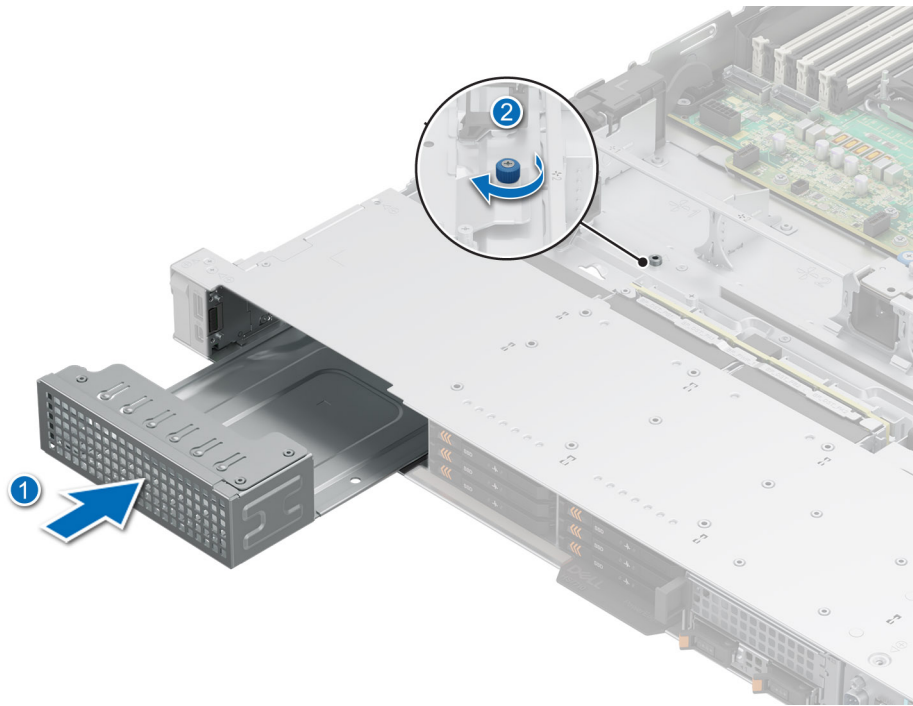

**Figure 233. Installing an OCP NIC card filler bracket**

### Next steps

Replace the front OCP NIC cage.

## Installing the front OCP NIC cage

### Prerequisites

1. Follow the safety guidelines listed in the [Safety instructions](#).
2. Follow the procedure listed in the [Before working inside your system](#).
3. [Remove the cooling fans](#).
4. [Remove the drive backplane cover](#).
5. Route and connect the cables, taking care not to damage them.

**i** **NOTE:** See [cable routing](#) section for more information.

**⚠ CAUTION:** Do not install GPUs, network cards, or other PCIe devices on your system that are not validated and tested by Dell. Damage caused by unauthorized and invalidated hardware installation will null and void the system warranty.

### Steps

1. If installed, remove the filler bracket from the front of the system by loosening the captive screw with a Phillips 2 screwdriver and then pulling the OCP NIC filler bracket out.

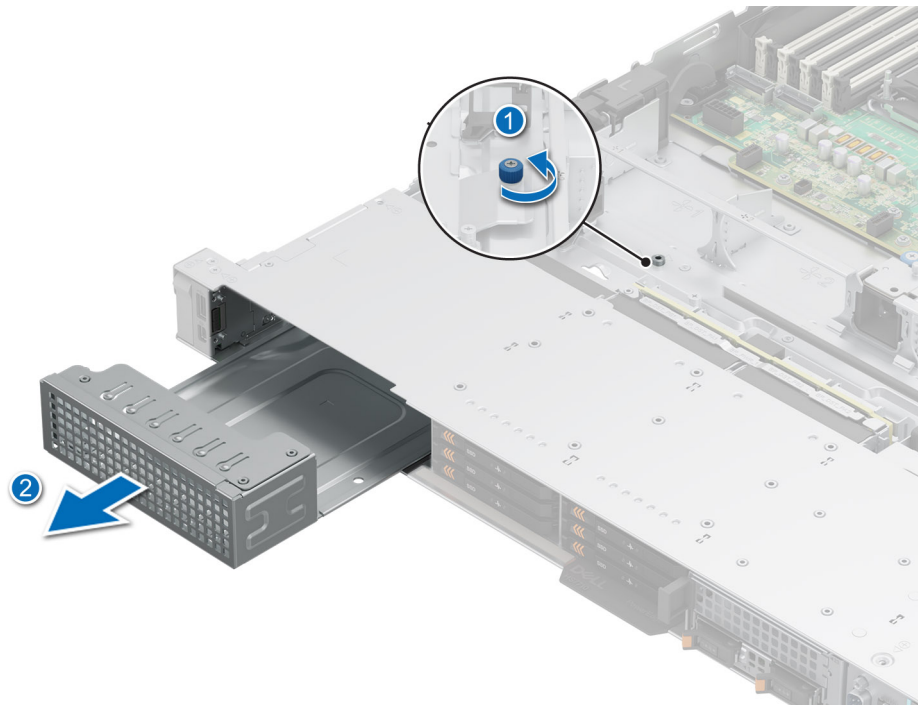

**Figure 234. Removing an OCP NIC card filler bracket**

2. Push and slide the OCP NIC cage into the front of the system.
3. Using the Phillips 2 screwdriver, tighten the thumb screw on the OCP NIC cage.

**NOTE:** The numbers on the image do not depict the exact steps. The numbers are for representation of sequence.

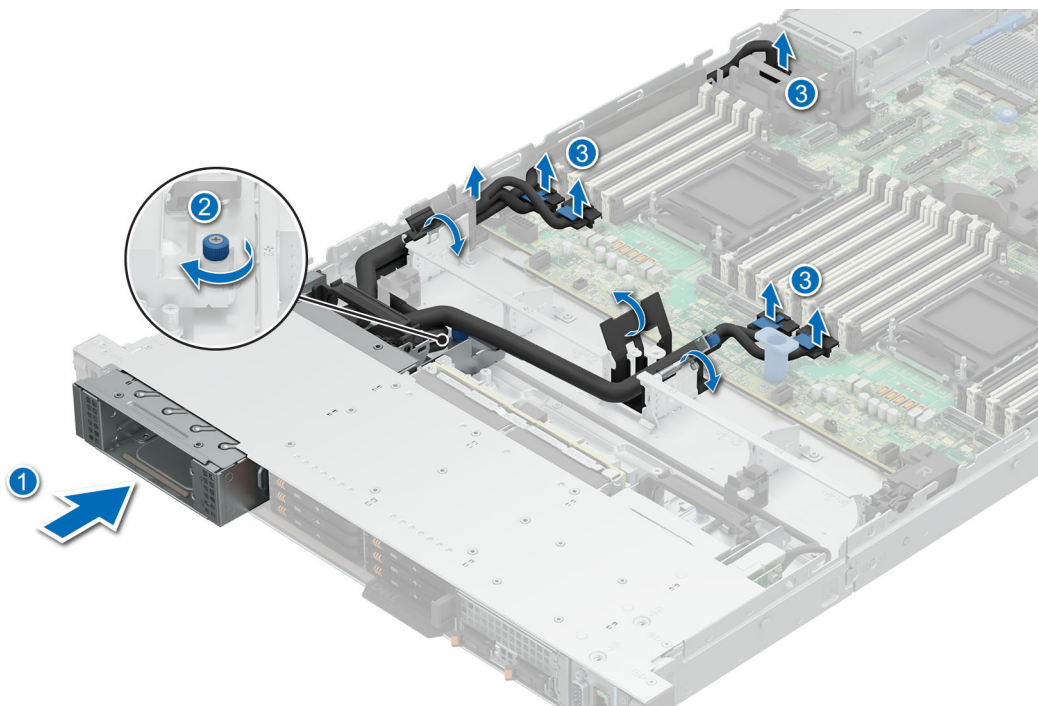

**Figure 235. Installing an OCP NIC cage to front of the system**

#### Next steps

Replace the front OCP NIC card.

# Removing the rear OCP NIC card

## Prerequisites

1. Follow the safety guidelines listed in the [Safety instructions](#).
2. Follow the procedure listed in the [Before working inside your system](#).
3. [Remove the rear expansion card riser](#) or [remove the rear expansion card riser blanks](#)

## Steps

1. Open the blue latch to disengage the OCP NIC card.
2. Push the OCP NIC card towards the rear end of the system to disconnect from the connector on the system board.
3. Slide the OCP NIC card out of the slot on the system.

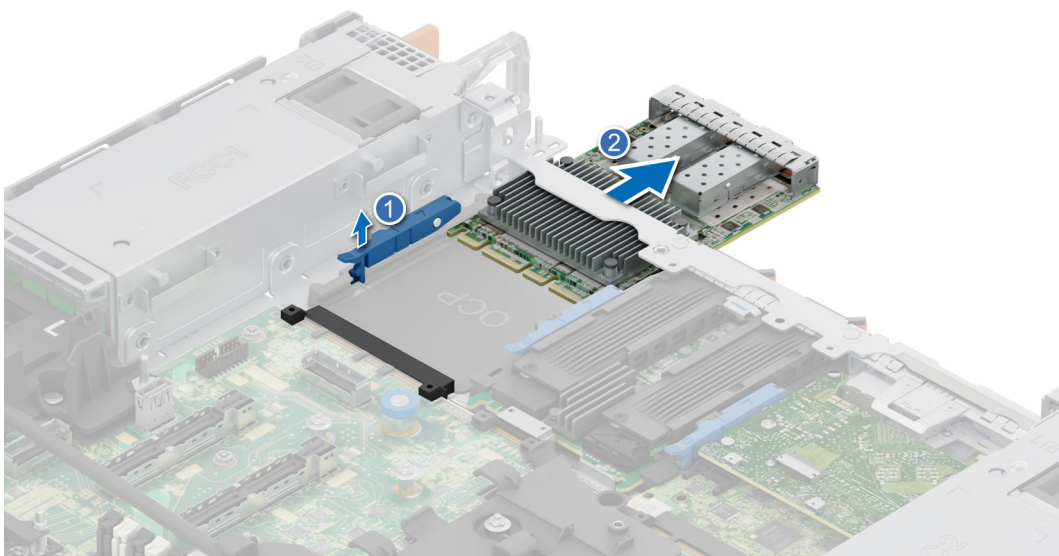

**Figure 236. Removing the rear OCP NIC card**

4. If the OCP NIC card is not going to be replaced, install a filler bracket .

**i** **NOTE:** You must install a filler bracket over an empty expansion card slot to maintain Federal Communications Commission (FCC) certification of the system. The brackets also keep dust and dirt out of the system and aid in proper cooling and airflow inside the system.

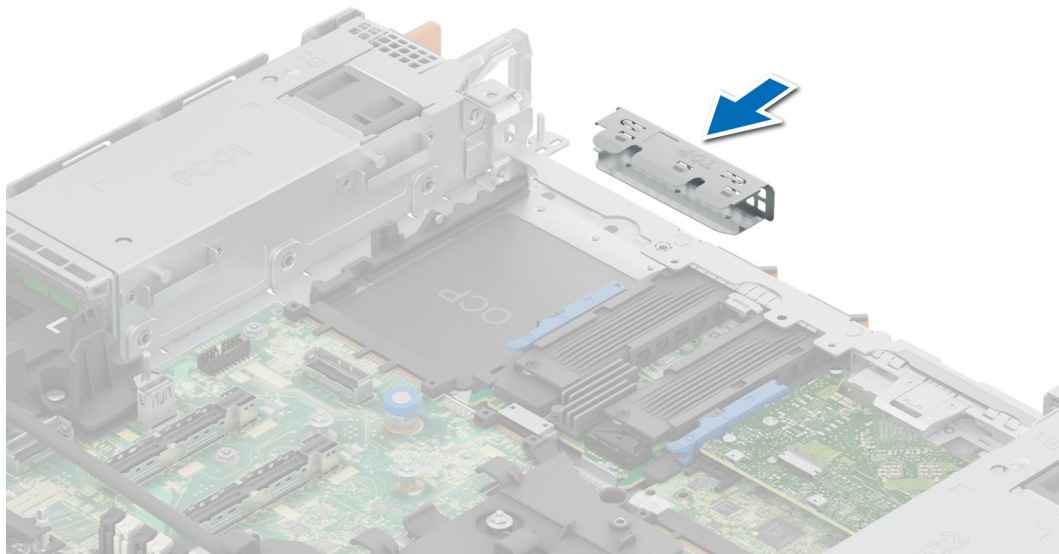

Figure 237. Installation of filler bracket

#### Next steps

1. [Replace the rear OCP NIC card.](#)

## Installing the rear OCP NIC card

#### Prerequisites

1. Follow the safety guidelines listed in the [Safety instructions](#).
2. Follow the procedure listed in the [Before working inside your system](#).
3. [Remove the rear expansion card riser](#) or [remove the rear expansion card riser blanks](#)

**CAUTION:** Do not install GPUs, network cards, or other PCIe devices on your system that are not validated and tested by Dell. Damage caused by unauthorized and invalidated hardware installation will null and void the system warranty.

#### Steps

1. If installed, remove the filler bracket.

**NOTE:** Store the filler bracket for future use. Filler brackets must be installed in empty expansion card slots to maintain Federal Communications Commission (FCC) certification of the system. The brackets also keep dust and dirt out of the system and aid in proper cooling and airflow inside the system.

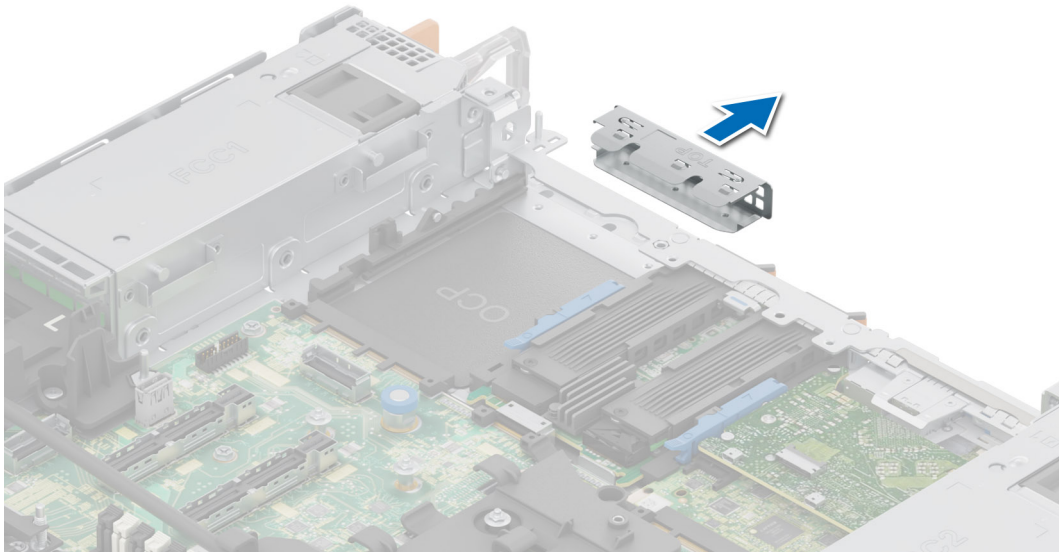

**Figure 238. Removal of filler bracket**

2. Open the blue latch on the system board.
3. Slide the OCP NIC card into the slot in the system.
4. Push until the OCP NIC card is connected to the connector on the system board.
5. Close the blue latch to lock the OCP NIC card to the system.

**NOTE:** The numbers on the image do not depict the exact steps. The numbers are for representation of sequence.

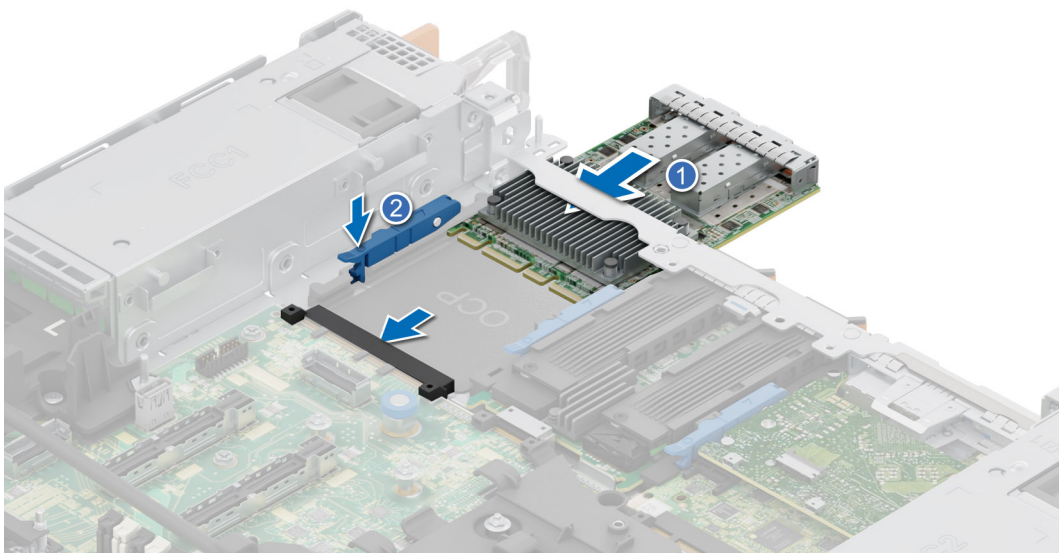

**Figure 239. Installing the rear OCP NIC card**

### Next steps

1. Route and connect the cables, taking care not to damage them.

**NOTE:** See [cable routing](#) section for more information.

2. [Install the rear expansion card riser](#) or [install the rear expansion card riser blanks](#)
3. Follow the procedure listed in [After working inside your system](#).

## Datacenter-Secure Control Module (DC-SCM)

This is a service technician replaceable part only.

### Removing the DC-SCM board

#### Prerequisites

1. Follow the safety guidelines listed in the [Safety instructions](#).
2. Follow the procedure listed in the [Before working inside your system](#).
3. [Remove the rear expansion card riser](#) or [remove the rear expansion card riser blanks](#)

#### Steps

1. Open the blue latch to disengage the DC-SCM board.
2. Push the DC-SCM board towards the rear end of the system to disconnect from the connector on the system board.
3. Slide the DC-SCM board out of the slot on the system.

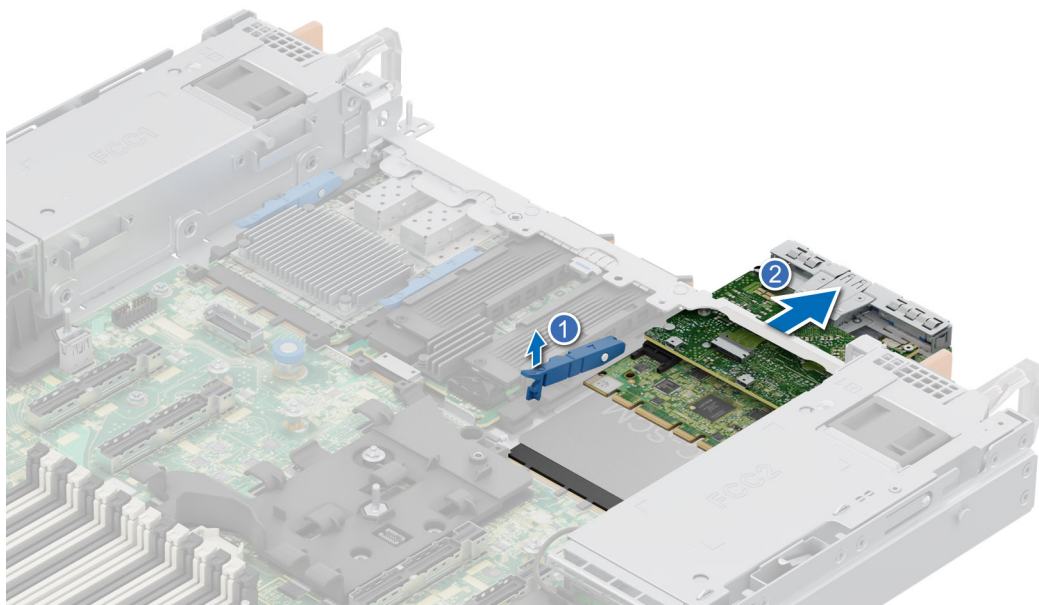

**Figure 240. Removing the DC-SCM board**

### Next steps

1. [Remove the Attic board](#).

**NOTE:** Disconnect the Attic cable, see Figure 8 [Cable routing](#) section.

**NOTE:** If a new DC-SCM board is being installed, the Attic board must be removed from the existing DC-SCM board.

2. Replace the DC-SCM board.

## Installing the DC-SCM board

### Prerequisites

1. Follow the safety guidelines listed in the [Safety instructions](#).
2. Follow the procedure listed in the [Before working inside your system](#).
3. [Remove the rear expansion card riser](#) or [remove the rear expansion card riser blank](#)
4. [Install the Attic board](#).

**NOTE:** Connect the Attic cable, see Figure 8 [cable routing](#) section.

**CAUTION:** Do not install GPUs, network cards, or other PCIe devices on your system that are not validated and tested by Dell. Damage caused by unauthorized and invalidated hardware installation will null and void the system warranty.

### Steps

1. Open the blue latch on the system board.
2. Slide the DC-SCM board into the slot in the system.
3. Push until the DC-SCM board is connected to the connector on the system board.
4. Close the blue latch to lock the DC-SCM board to the system.

**NOTE:** The numbers on the image do not depict the exact steps. The numbers are for representation of sequence.

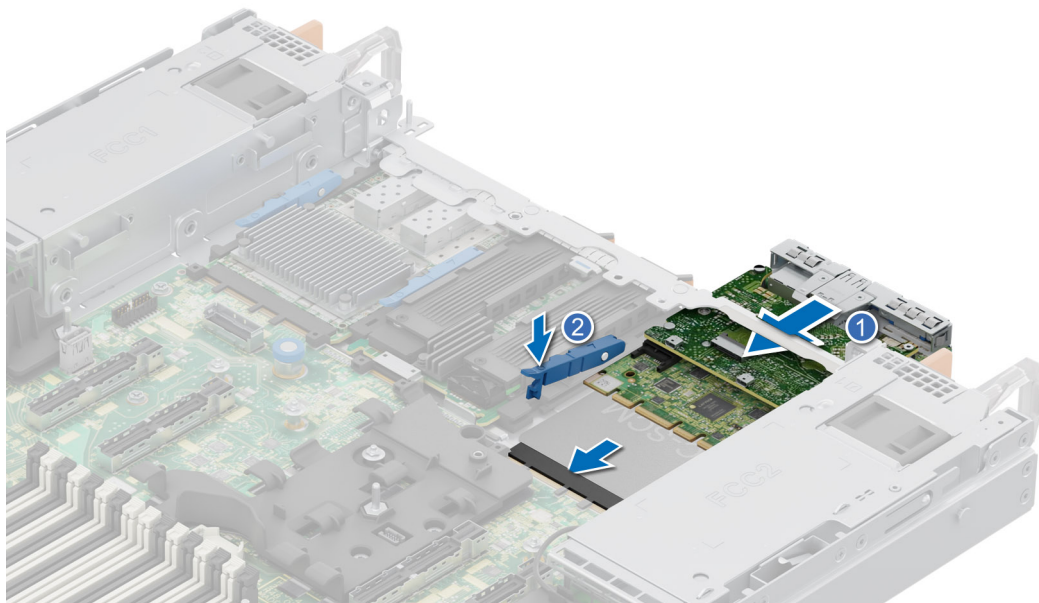

**Figure 241. Installing the DC-SCM board**

### Next steps

1. [Install the rear expansion card riser](#) or [install the rear expansion card riser blanks](#)
2. Power on the system.
3. Ensure that you perform the following steps:

- a. Use the Easy Restore feature to restore the BIOS, iDRAC, and Service Tag. See the [Restoring the system using the Easy Restore feature](#) section.
  - b. If the service tag is not backed up in the backup flash device, enter the system service tag manually. See the [Manually update the Service Tag](#) by using System Setup section.
  - c. Install BIOS and iDRAC version updates, Diagnostics, and OS Driver Pack and OS Collector.
  - d. Re-enable the Trusted Platform Module (TPM). See the [Upgrading the Trusted Platform Module](#) section.
4. Follow the procedure listed in [After working inside your system](#).

## Restoring the system using Easy Restore

The Easy Restore feature restores the server service tag and BIOS configuration data after replacing the Datacenter-Secure Control Module (DC-SCM). System configuration data is automatically maintained in a backup flash device within the system. If the BIOS detects a new DC-SCM during server boot, the system prompts the user to restore the backup system configuration data.

### About this task

For more information about the Easy Restore feature, see iDRAC User's Guide at [iDRAC Manuals](#).

When the DC-SCM is booted for the first time, it presents a screen with settings it can restore, below is a list of options/steps available:

### Steps

1. To restore the system configuration data, press **Y**
2. To skip restore for this boot, press **N**
3. Enter BIOS setup to manually restore Service Tag, press **F2**

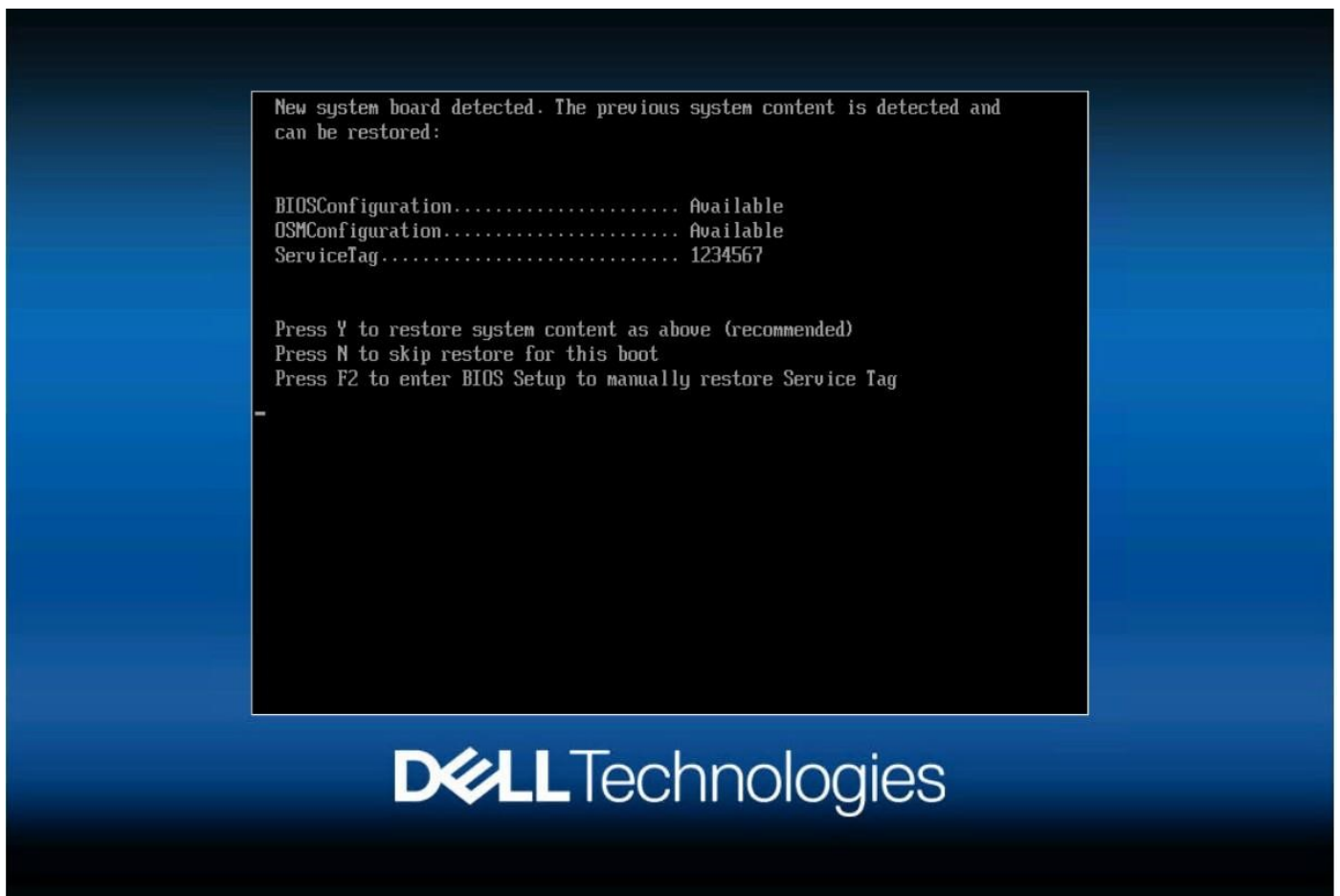

Figure 242. Easy Restore

## Manually update the Service Tag

After replacing a HPM board, if Easy Restore fails, follow this process to manually enter the Service Tag, using **System Setup**.

### About this task

If you know the system service tag, use the **System Setup** menu to enter the service tag.

### Steps

1. Power on the system.
2. To enter the **System Setup**, press **F2**.
3. Click **Service Tag Settings**.
4. Enter the service tag.

**NOTE:** You can enter the service tag only when the **Service Tag** field is empty. Ensure that you enter the correct service tag. Once the service tag is entered, it cannot be updated or changed. Incorrectly entered service tag will lead to HPM board replacement.

5. Click **OK**.

## Attic board

This is a service technician replaceable part only.

## Removing the Attic board

### Prerequisites

1. Follow the safety guidelines listed in the [Safety instructions](#).
2. Follow the procedure listed in the [Before working inside your system](#).
3. [Remove the rear expansion card riser](#) or [remove the rear expansion card riser blanks](#)
4. [Remove the DC-SCM board](#).

### Steps

1. Using the Phillips 1 screwdriver, loosen the captive screws securing the attic board to the DC-SCM board.
2. Tilt and lift the Attic board from the DC-SCM guide pins.

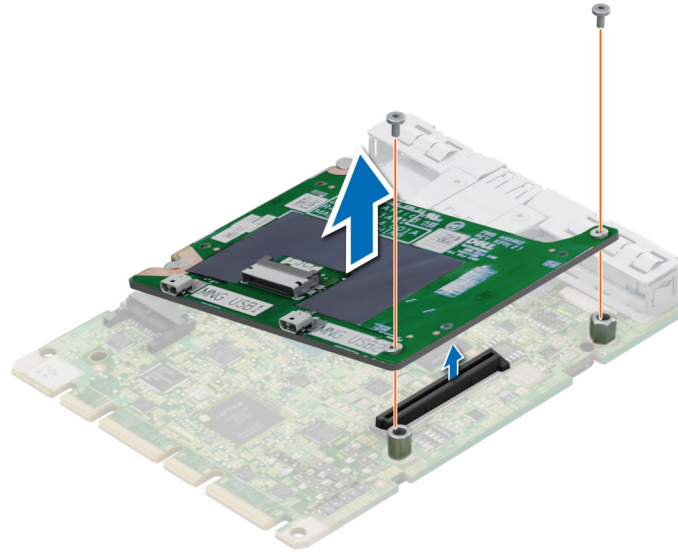

Figure 243. Removing the Attic board

#### Next steps

1. [Replace the Attic board.](#)

## Installing the Attic board

#### Prerequisites

1. Follow the safety guidelines listed in the [Safety instructions](#).
2. Follow the procedure listed in the [Before working inside your system](#).
3. [Remove the rear expansion card riser](#) or [remove the rear expansion card riser blanks](#)
4. [Remove the DC-SCM board](#).

**CAUTION:** Do not install GPUs, network cards, or other PCIe devices on your system that are not validated and tested by Dell. Damage caused by unauthorized and invalidated hardware installation will null and void the system warranty.

#### Steps

1. Align the Attic board at an angle with the guide pins on the DC-SCM board.
2. Press until the Attic board is connected to the connector on the DC-SCM board.
3. Using a Phillips 1 screwdriver, tighten the captive screws.

**NOTE:** The numbers on the image do not depict the exact steps. The numbers are for representation of sequence.

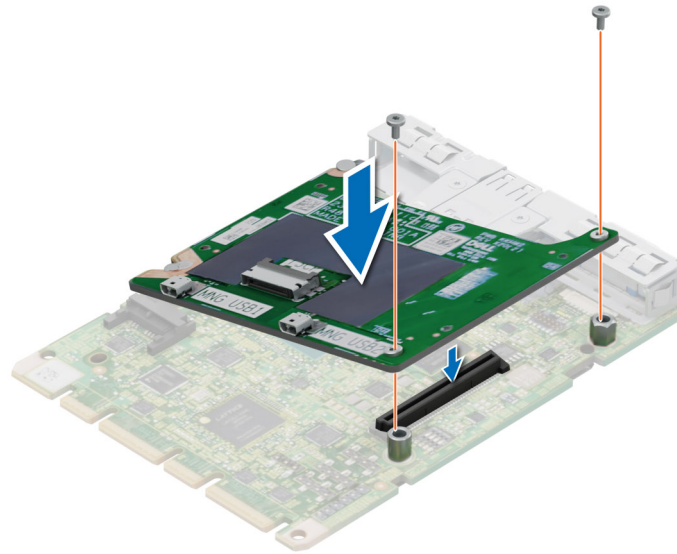

Figure 244. Installing the Attic board

#### Next steps

1. Install the DC-SCM board.
2. Install the rear expansion card riser or install the rear expansion card riser blank
3. Follow the procedure listed in [After working inside your system.](#)

## Optional internal USB port

This is a service technician replaceable part only.

## Removing the internal USB device

#### Prerequisites

**CAUTION:** To avoid interference with other components in the server, the maximum permissible dimensions of the USB memory key are 15.9 mm wide x 57.15 mm long x 7.9 mm high.

1. Follow the safety guidelines listed in the [Safety instructions.](#)
2. Follow the procedure listed in the [Before working inside your system.](#)
3. [Remove the rear expansion card riser](#) or [remove the rear expansion card riser blanks](#)

#### Steps

Lift the internal USB device to disconnect from the connector on the system board.

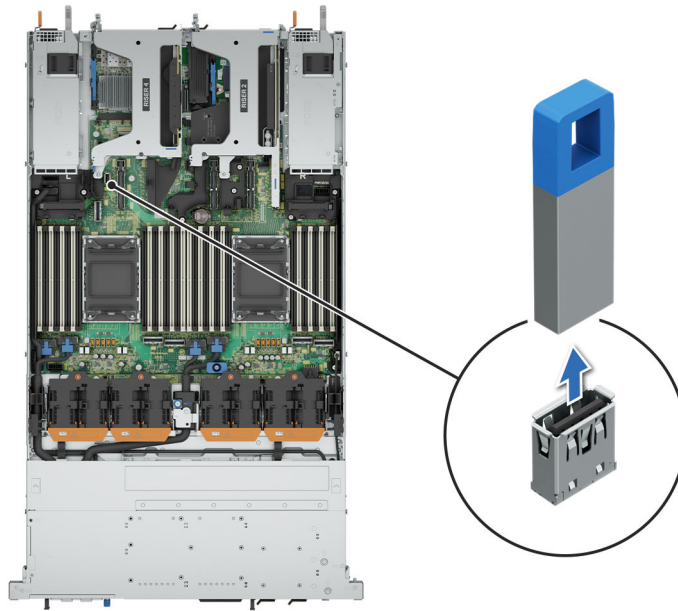

**Figure 245. Removing the internal USB device**

#### **Next steps**

1. [Replace the internal USB card.](#)

## **Installing the Internal USB device**

#### **Prerequisites**

1. Follow the safety guidelines listed in the [Safety instructions](#).
2. Follow the procedure listed in the [Before working inside your system](#).
3. [Remove the rear expansion card riser](#) or [remove the rear expansion card riser blanks](#)

#### **Steps**

Align the internal USB device with the USB port on the system board and press firmly until it is properly seated.

**i** **NOTE:** For information about the exact location of USB port on system board, see [System board jumpers and connectors](#) section.

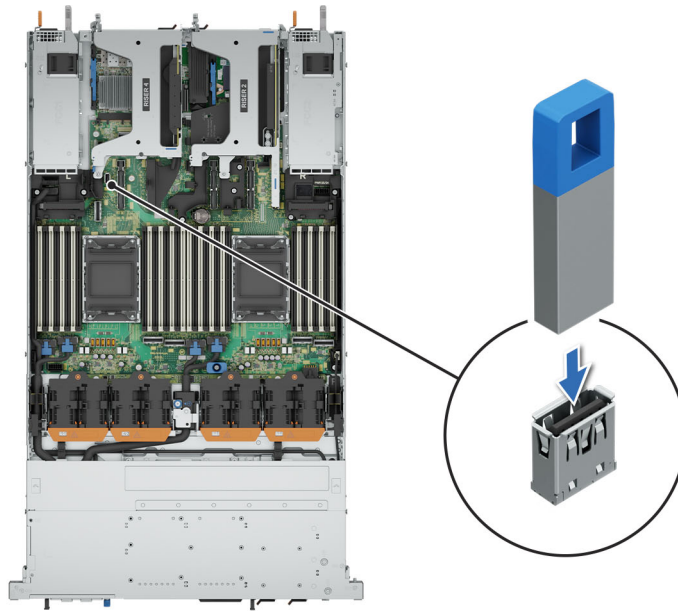

**Figure 246. Installing the internal USB device**

#### Next steps

1. [Install the rear expansion card riser](#) or [install the rear expansion card riser blank](#)
2. Follow the procedure listed in [After working inside your system](#).
3. While booting, press F2 to enter **System Setup** and verify that the system detects the USB memory key.

## System battery

This is a service technician replaceable part only.

## Replacing the system battery

#### Prerequisites

**⚠ WARNING:** There is a danger of a new battery exploding if it is incorrectly installed. Replace the battery only with the same or equivalent type that is recommended by the manufacturer. Discard used batteries according to the manufacturer's instructions. See the Safety instructions that came with your system for more information.

1. Follow the safety guidelines listed in the [Safety instructions](#).
2. Follow the procedure listed in the [Before working inside your system](#).
3. If applicable, disconnect the power or data cables from the expansion cards.
4. [Remove the rear expansion card riser](#) or [remove the rear expansion card riser blanks](#)

#### Steps

1. Press and hold the battery socket retention latch, for the battery to pop out.

**i NOTE:** If the battery does not pop out, then lift it out of the socket.

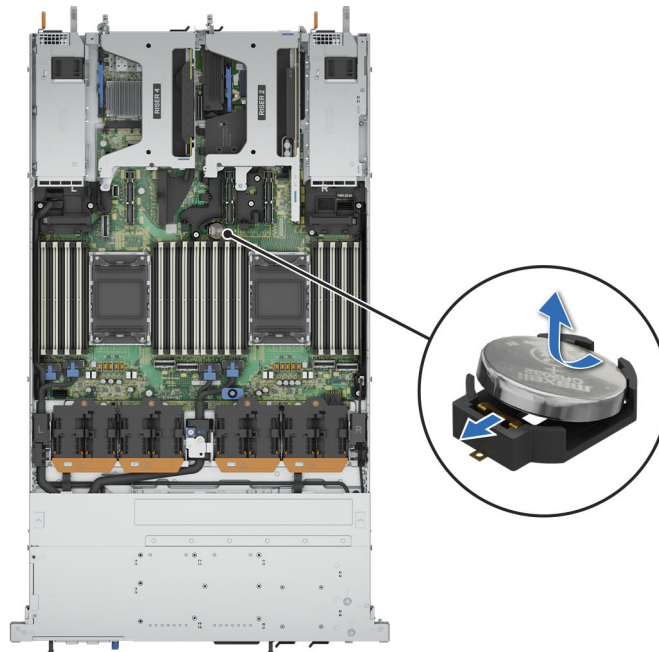

**Figure 247. Removing the system battery**

2. To install a new system battery, hold the battery with the positive side facing up at an angle and slide it under the battery holder socket latch.
3. Press the battery into the connector until it snaps into place.

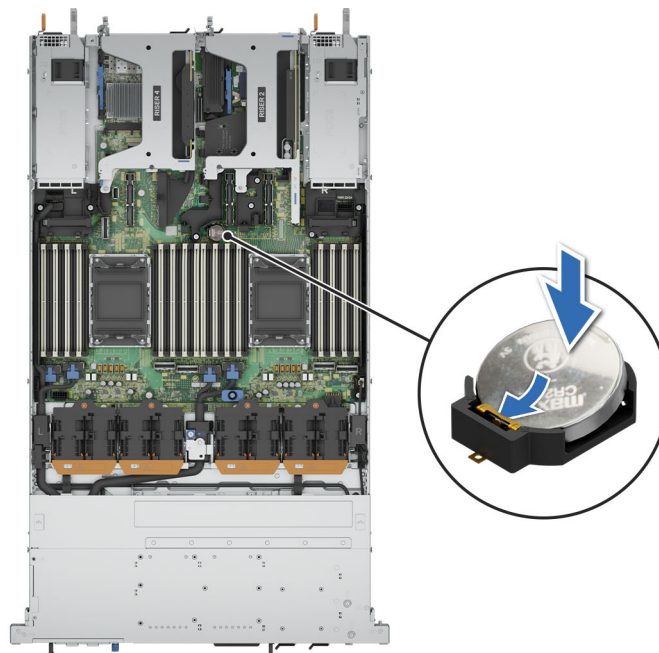

**Figure 248. Installing the system battery**

#### **Next steps**

1. [Install the rear expansion card riser or install the rear expansion card riser blank](#)
2. If applicable, connect the cables to one or more expansion cards.
3. Follow the procedure listed in [After working inside your system](#).
4. Confirm that the battery is operating properly, by performing the following steps:
  - a. Enter the System Setup, while booting, by pressing F2.

- b. Enter the correct time and date in the System Setup **Time** and **Date** fields.
- c. **Exit** the System Setup.
- d. To test the newly installed battery, check the time and date at least an hour after installing the battery.
- e. Enter the System Setup and if the time and date are still incorrect, see [Getting help](#) section.

## Intrusion switch

This is a service technician replaceable part only.

### Removing the intrusion switch module

#### Prerequisites

1. Follow the safety guidelines listed in the [Safety instructions](#).
2. Follow the procedure listed in the [Before working inside your system](#).
3. [Remove the rear expansion card riser](#) or [remove the rear expansion card riser blanks](#)

**i** **NOTE:** Ensure that you note the routing of the cable as you remove it from the HPM board. Route the cable properly when you replace it to prevent the cable from being pinched or crimped. The cable routing instructions in Figure 8. here [Cable routing](#)

#### Steps

1. Using a Phillips 1 screwdriver, loosen the screws on the intrusion switch module.
2. Disconnect the intrusion switch cable from the dongle cable .

**i** **NOTE:** The intrusion switch cable is connected to the dongle cable, which in turn is connected to the HPM board.

3. Disconnect the dongle cable from the J2 slot connector on the HPM board.

**i** **NOTE:** Detach the dongle cable from the intrusion switch and keep it safe to be used when replacing with the new intrusion switch.

4. Lift the intrusion switch module along with dongle cable out of the system.

**i** **NOTE:** The numbers on the image do not depict the exact steps. The numbers are for representation of sequence.

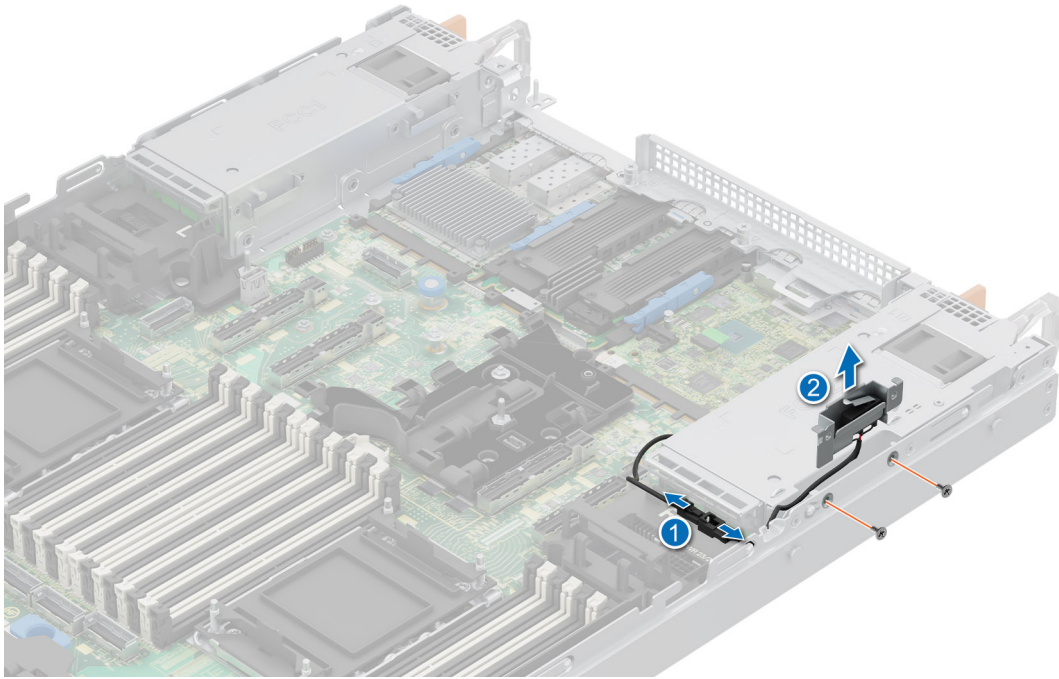

Figure 249. Removing the intrusion switch module

#### Next steps

1. [Replace the intrusion switch module.](#)

## Installing the intrusion switch module

#### Prerequisites

1. Follow the safety guidelines listed in the [Safety instructions](#).
2. Follow the procedure listed in [Before working inside your system](#).
3. [Remove the rear expansion card riser](#) or [remove the rear expansion card riser blanks](#)

#### Steps

1. Align and place the intrusion switch module into the system.
2. Using a Phillips 1 screwdriver, tighten the screws to secure the intrusion switch module to the system chassis.
3. Connect the dongle cable and the intrusion switch cable.
4. Arrange the dongle cable on the holder and route the dongle cable to pass through the clips.  
**NOTE:** Route the cable properly when you replace it on the HPM board to prevent the cable from being pinched or crimped. See the cable routing instructions in Figure 8. here [Cable routing](#).
5. Reconnect the dongle cable in the J2 connector on the HPM board.  
**NOTE:** The intrusion switch cable is connected to the dongle cable, which in turn is connected to the system board.

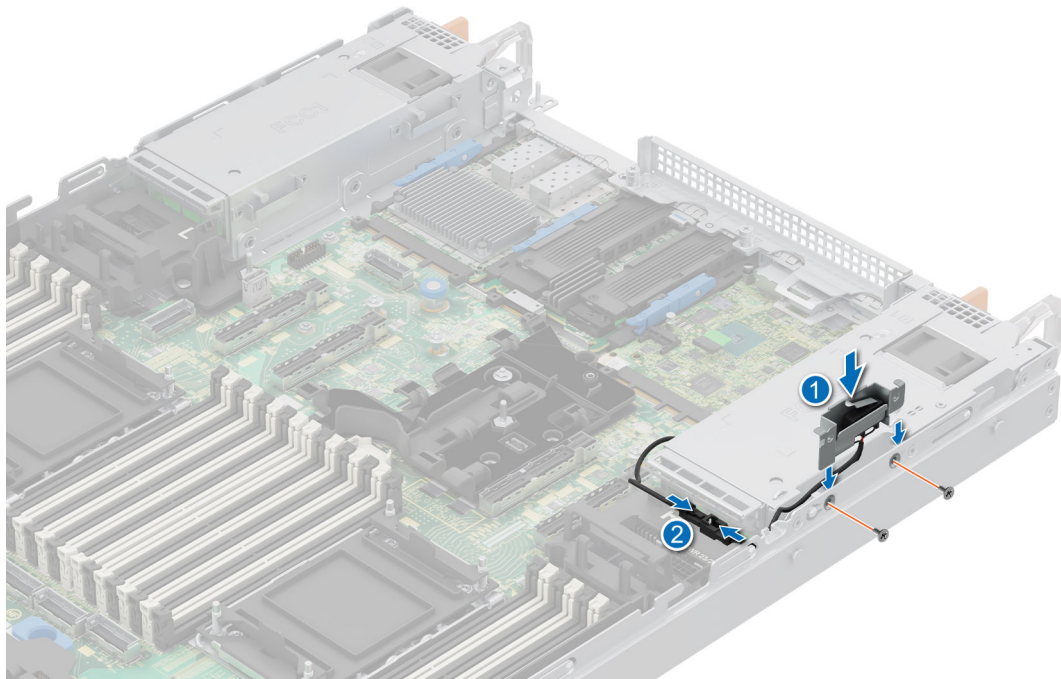

Figure 250. Installing the intrusion switch module

#### Next steps

1. Install the rear expansion card riser or install the rear expansion card riser blank
2. Follow the procedure listed in [After working inside your system](#).

## Power supply unit

### Removing a power supply unit

#### Prerequisites

**CAUTION:** The system requires one power supply unit (PSU) for normal operation. On power-redundant systems, remove and replace only one PSU at a time in a system that is powered on.

1. Follow the safety guidelines listed in the [Safety instructions](#).
2. Disconnect the power cable from the power outlet and from the PSU that you intend to remove.
3. Remove the cable from the strap on the PSU handle.
4. Unlatch and lift or remove the optional cable management accessory if it interferes with the PSU removal.

**NOTE:** For information about the cable management when the PSU is removed or installed while the system is in a rack, see the system's cable management arm documentation at [PowerEdge Manuals](#).

#### Steps

Press the release latch and holding the PSU handle, slide the PSU out of the bay.

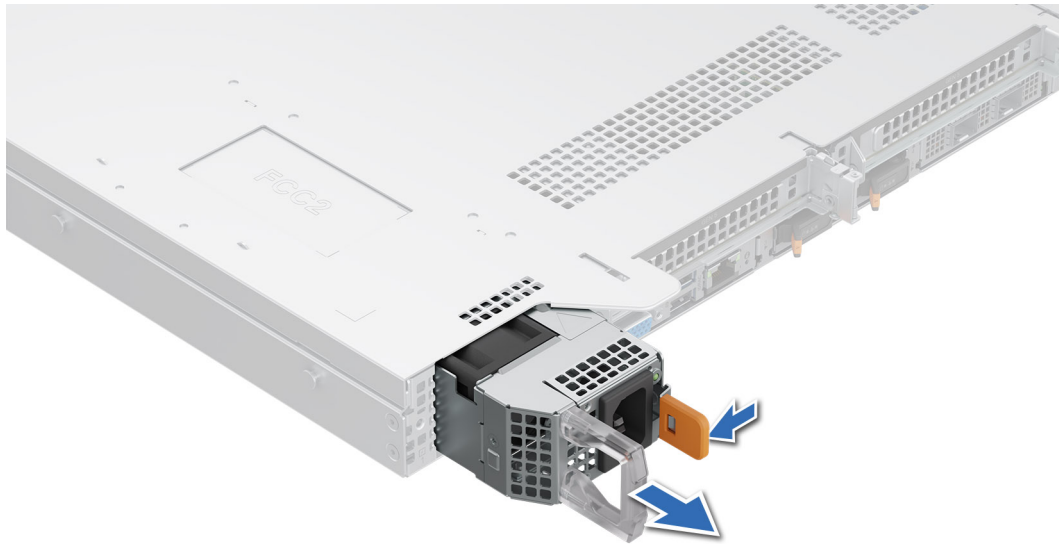

**Figure 251. Removing a power supply unit**

#### Next steps

1. [Replace the PSU](#) or [install the PSU blank](#).

## Installing a power supply unit

#### Prerequisites

1. Follow the safety guidelines listed in the [Safety instructions](#).
2. For systems that support redundant PSU, ensure that both the PSUs are of the same type and have the same maximum output power.

**NOTE:** The maximum output power (shown in watts) is listed on the PSU label.

3. If required, [Remove the PSU blank](#).

#### Steps

Slide the PSU into the PSU bay until the release latch snaps into place.

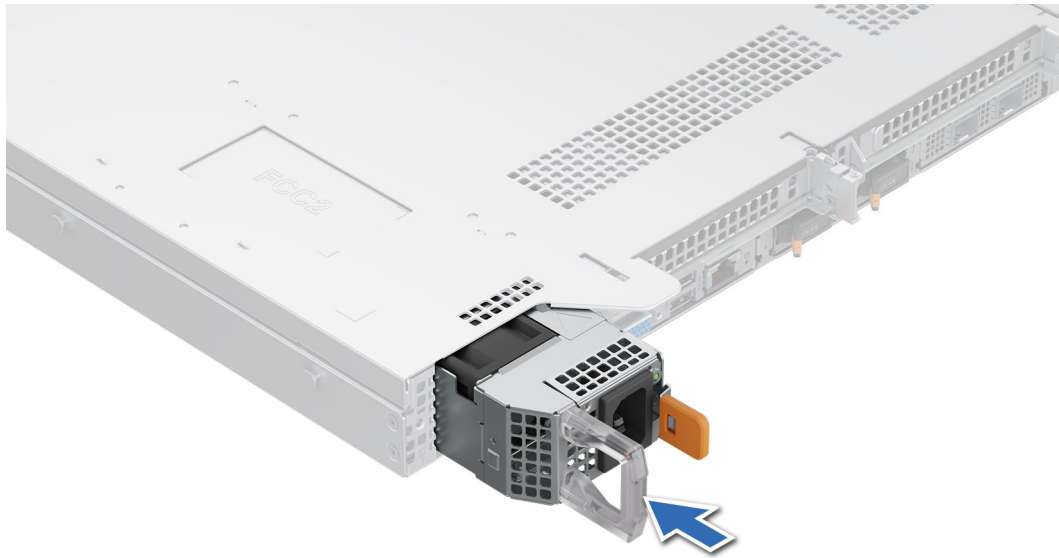

**Figure 252. Installing a power supply unit**

#### Next steps

1. If you have unlatched or removed the cable management accessory, reinstall or relatch it. For information about the cable management when the PSU is removed or installed while the system is in the rack, see the system's cable management accessory documentation at [PowerEdge Manuals](#).
2. Connect the power cable to the PSU, and plug the cable into a power outlet.

**CAUTION:** When connecting the power cable to the PSU, secure the cable to the PSU with the strap.

**NOTE:** When installing hot swapping, or hot adding a new PSU, wait for 15 seconds for the system to recognize the PSU and determine its status. The PSU redundancy may not occur until discovery is complete. The PSU status indicator turns green to indicate that the PSU is functioning properly.

## Removing a power supply unit blank

#### Prerequisites

Follow the safety guidelines listed in the [Safety instructions](#).

#### Steps

Pull the blank out of the system.

**CAUTION:** For proper system cooling, the PSU blank must be installed in the second PSU bay in a non-redundant configuration. Remove the PSU blank only if you are installing a second PSU.

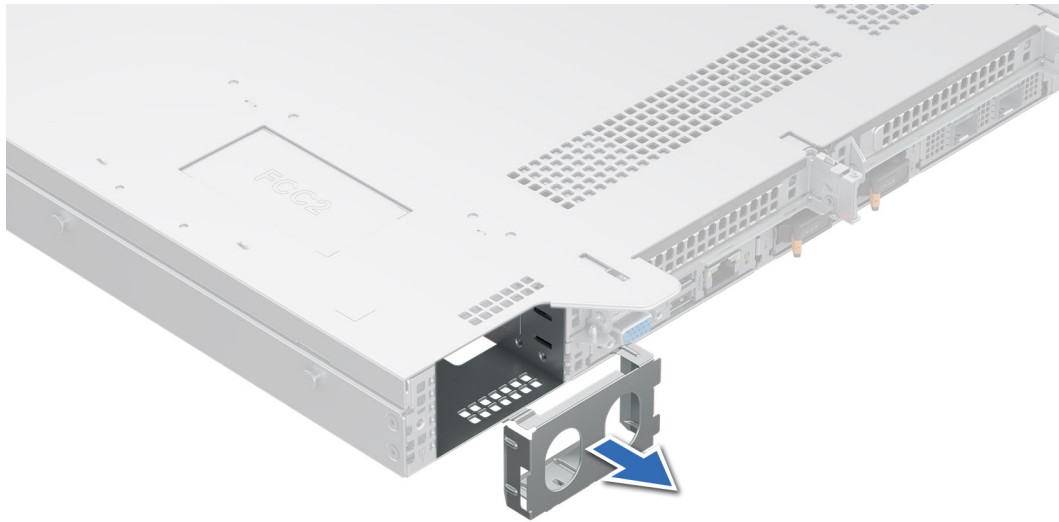

**Figure 253. Removing a power supply unit blank**

#### Next steps

1. [Replace the PSU blank](#) or [install the PSU](#).

## Installing a power supply unit blank

#### Prerequisites

1. Follow the safety guidelines listed in the [Safety instructions](#).

**NOTE:** Install the power supply unit (PSU) blank only in the second PSU bay.

2. If required, [Remove the PSU](#).

#### Steps

Align the PSU blank with the PSU bay and push it into the PSU bay until it clicks into place.

**NOTE:** Make sure that the "Top" mark on the PSU blank is on the upper side.

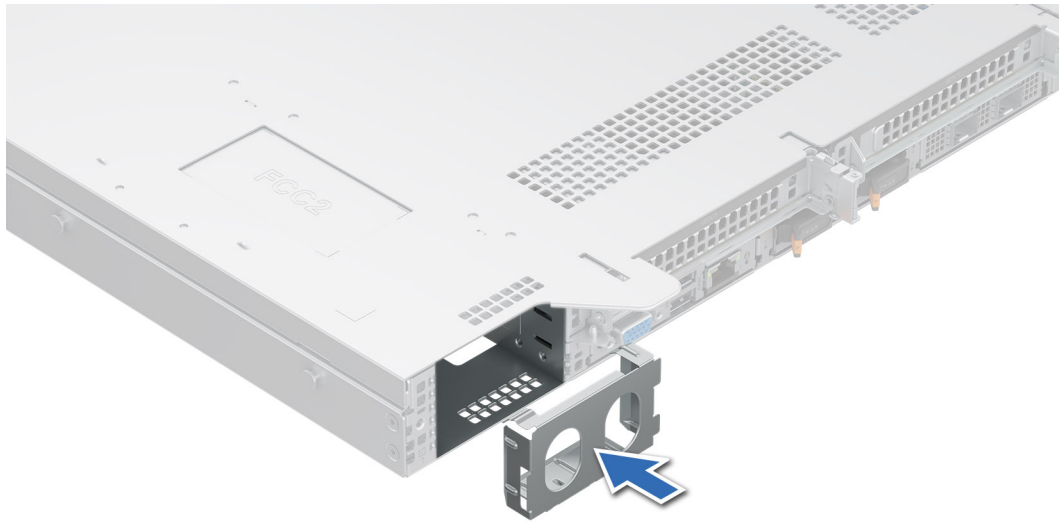

**Figure 254. Installing a power supply unit blank**

## DB9+RJ45 module

This is a service technician replaceable part only.

### Removing the DB9+RJ45 module

#### Prerequisites

1. Follow the safety guidelines listed in the [Safety instructions](#).
2. Follow the procedure listed in the [Before working inside your system](#).
3. [Remove the cooling fans](#).
4. [Remove the drive backplane cover](#).

#### Steps

1. Disconnect the DB9+RJ45 port cable from the system board.
2. Using Phillips 2 screwdriver, remove the screw on the DB9+RJ45 module. Slide the module out of the system.

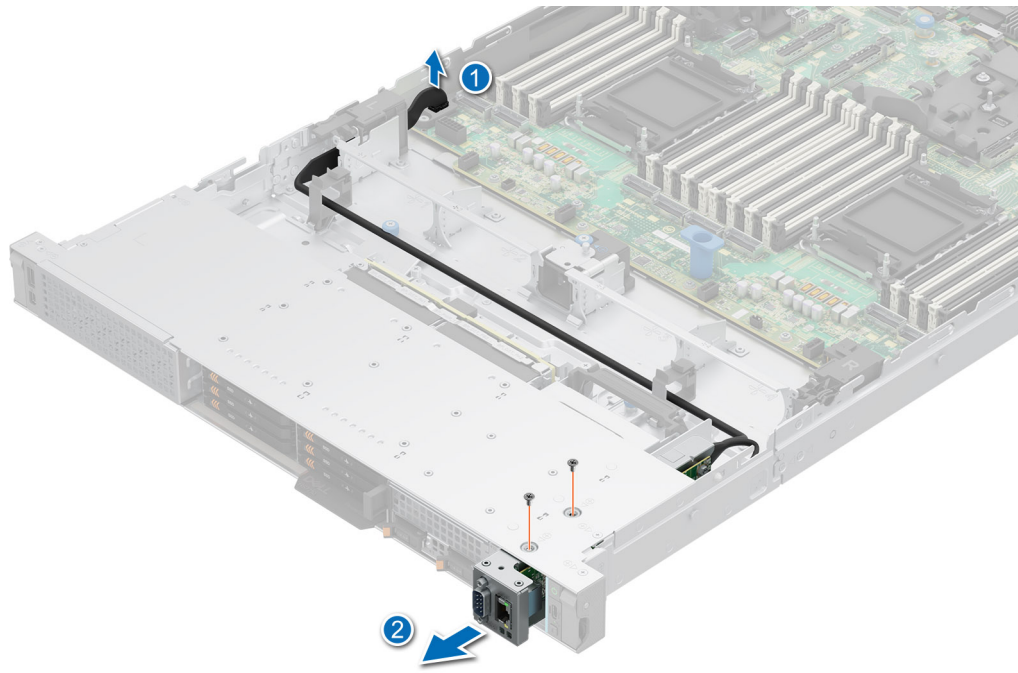

**Figure 255. Disconnecting the DB9+RJ45 module**

#### **Next steps**

1. [Replace the DB9+RJ45 module.](#)

## **Installing the DB9+RJ45 module**

#### **Prerequisites**

1. Follow the safety guidelines listed in the [Safety instructions](#).
2. Follow the procedure listed in [Before working inside your system](#).
3. [Remove the cooling fans](#).
4. [Remove the drive backplane cover](#).

#### **Steps**

1. Align the hole on the module with the screw hole on the system.
2. Route the DB9+RJ45 cable through the side bracket. Reconnect the DB9+RJ45 cable on the system board.
3. Using the Phillips 2 screwdriver, secure the DB9+RJ45 module to the system with the screw.

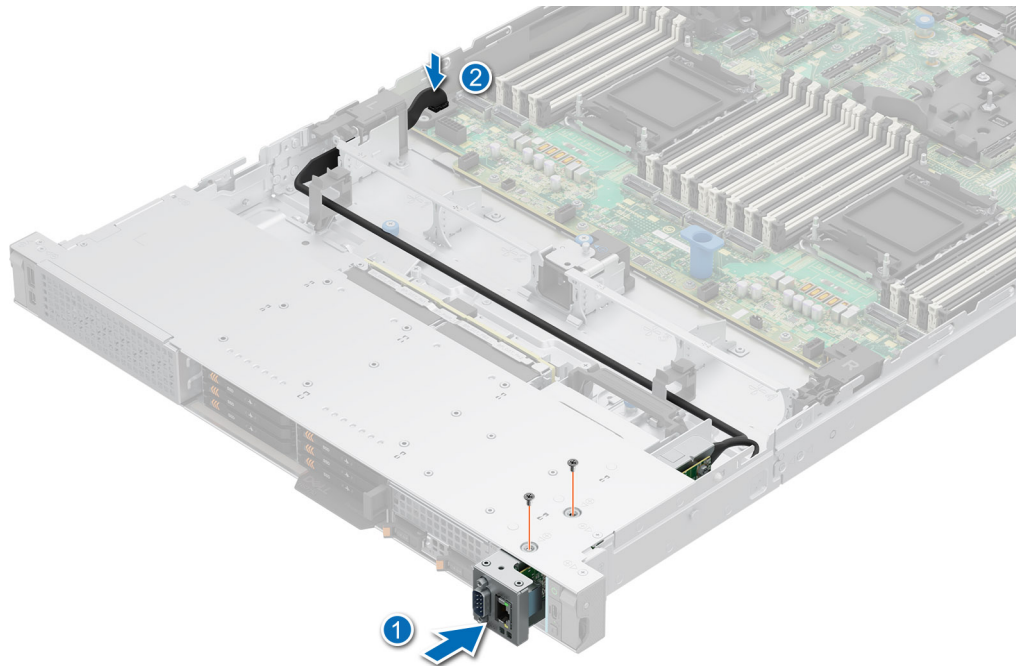

**Figure 256. Installing the DB9+RJ45 port**

#### Next steps

1. Route and connect the cables, taking care not to damage them.

**NOTE:** See [cable routing](#) section for more information.

2. [Install the cooling fans.](#)
3. [Install the drive backplane cover.](#)
4. Follow the procedure listed in [After working inside your system.](#)

## Trusted Platform Module

TPM is soldered down to the DC-SCM.

If the Trusted Platform Module (TPM) is identified as the root cause of the problem, a full DC-SCM replacement is necessary.

For more information on TPM see [Trusted Platform Module \(TPM\) Summary](#).

## Initializing TPM 2.0 for users

#### Steps

1. Initialize the TPM.
  - a. While booting your system, press F2 to enter System Setup.
  - b. On the **System Setup Main Menu** screen, click **System BIOS > System Security Settings**.
  - c. From the **TPM Security** option, select **On**.
  - d. Save the settings.
  - e. Restart your system.
2. The **TPM Status** changes to **Enabled, Activated**.

# HPM board

This is a service technician replaceable part only.

 **NOTE:** System board is known as Host Processor Module (HPM) board.

## Removing the HPM board

### Prerequisites

 **CAUTION:** If you are using the Trusted Platform Module (TPM) with an encryption key, you may be prompted to create a recovery key during program or System Setup. Be sure to create and safely store this recovery key. If you replace this HPM board, you must supply the recovery key when you restart your system or program before you can access the encrypted data on your drives.

1. Follow the safety guidelines listed in the [Safety instructions](#).
2. Follow the procedure listed in the [Before working inside your system](#).
3. Remove the following components:
  - a. [Cooling fans](#)
  - b. [Side wall bracket](#)
  - c. [Middle bracket](#)
  - d. [Memory modules](#)
  - e. [Rear expansion card risers](#) or [rear expansion card riser blanks](#)
  - f. [Processor and heat sink module](#)
  - g. [Rear OCP \(if installed\)](#)
  - h. [Rear BOSS-N1 DC-MHS](#)
  - i. [DC-SCM](#)
  - j. [Internal USB memory key \(if installed\)](#)
  - k. [Power supply units \(PSU\)](#)
  - l. Disconnect all the cables from the HPM board and make note of all the cable connections.

 **CAUTION:** Take care not to damage the system identification button while removing the HPM board from the system.

 **CAUTION:** Do not lift the system board by holding a memory module, processor, or other components.

### Steps

1. Using the HPM board holder and plunger, slide the HPM board towards the front of the system.
2. Securely hold the holder and plunger to carefully lift the HPM board out of the chassis.

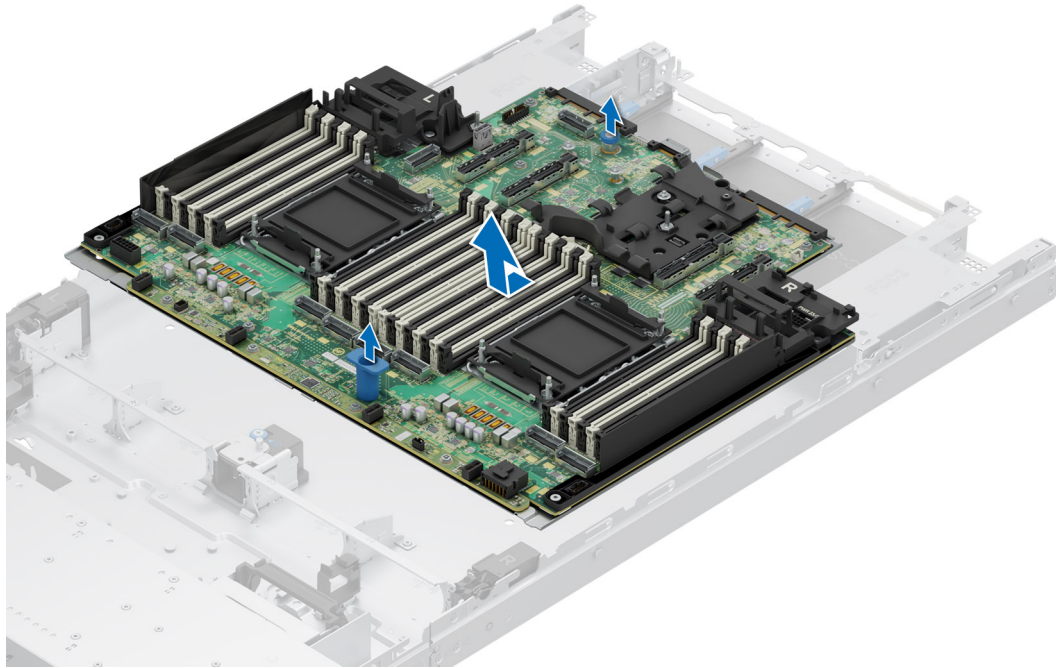

Figure 257. Removing the HPM board

#### Next steps

1. [Install the HPM board.](#)

## Installing the HPM board

#### Prerequisites

1. Follow the safety guidelines listed in the [Safety instructions](#).
2. Follow the procedure listed in [Before working inside your system](#).
3. If you are replacing the HPM board, remove all the components that are listed in the removing the HPM board section.

#### Steps

1. Unpack the new HPM board assembly.

**CAUTION:** Do not lift the system board by holding a memory module, processor, or other components.

**CAUTION:** Take care not to damage the system identification button while placing the HPM board into the chassis.

2. Holding the HPM board holder and plunger, align and lower the HPM board into the system.
3. Slide the HPM board towards the rear of the chassis until the connectors are firmly seated in the slots.

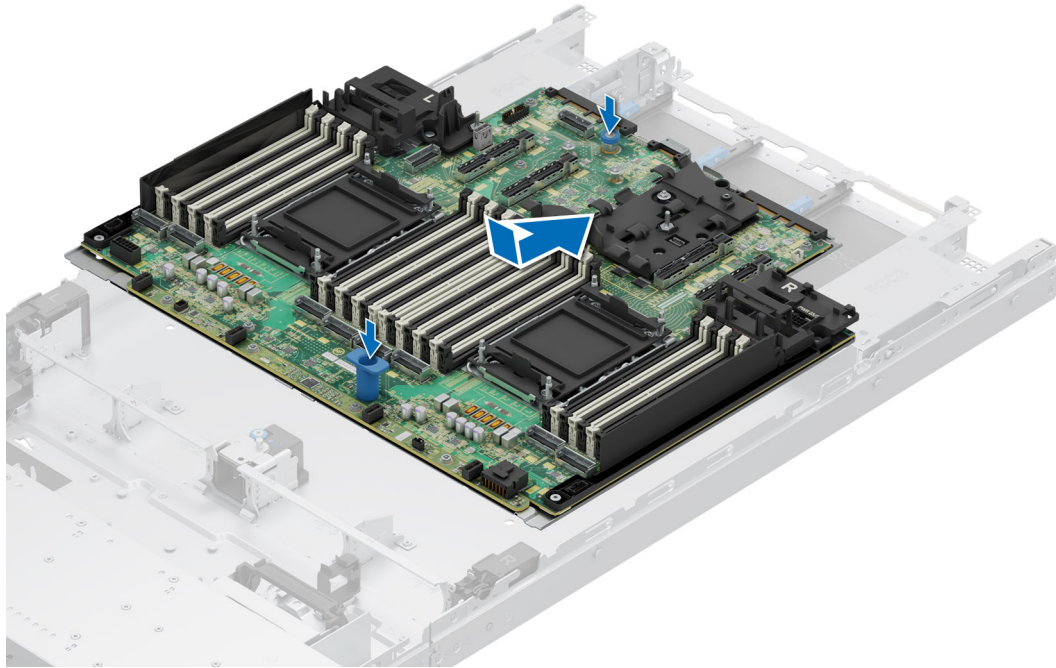

**Figure 258. Installing the HPM board**

### Next steps

1. Replace the following components:
  - a. [Internal USB memory key \(if removed\)](#)
  - b. [Rear OCP card \(if removed\)](#)
  - c. [Rear BOSS-N1 DC-MHS](#)
  - d. [DC-SCM](#)
  - e. [Processor and heat sink module](#)
  - f. [Memory modules](#)
  - g. [Rear expansion card risers](#) or [rear expansion card riser blanks](#)
  - h. [Middle bracket](#)
  - i. [Side wall bracket](#)
  - j. [Cooling fans](#)
  - k. [Power supply units \(PSU\)](#)
2. Reconnect all cables to the HPM board.

**NOTE:** Ensure that the cables inside the system are routed along the chassis wall and secured using the cable securing bracket.

3. Follow the procedure listed in [After working inside your system](#).

## Control panel

This is a service technician replaceable part only.

## Removing the right control panel

### Prerequisites

1. Follow the safety guidelines listed in the [Safety instructions](#).
2. Follow the procedure listed in the [Before working inside your system](#).

3. Remove the drive backplane cover.
4. Remove the side wall bracket.

### Steps

1. Disconnect the right control panel cable and the VGA cable from the connectors on the system board.
2. Using the Phillips 1 screwdriver, remove the screws that secure the right control panel and cable cover to the system.
3. Remove the cable cover away from the system.
4. Holding the right control panel, slide the right control panel out of the system.

**i** **NOTE:** Observe the routing of the cable assembly as you remove the right control panel from the system.

**i** **NOTE:** The numbers on the image do not depict the exact steps. The numbers are for representation of sequence.

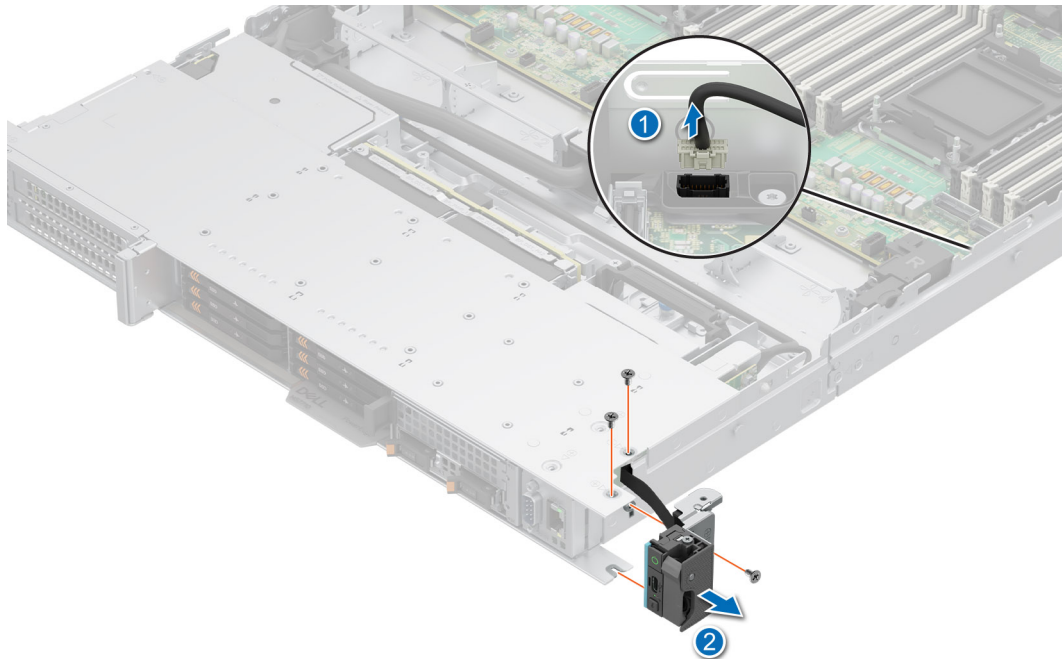

**Figure 259. Removing the right control panel**

### Next steps

1. Replace the right control panel.

## Installing the right control panel

### Prerequisites

1. Follow the safety guidelines listed in the [Safety instructions](#).
2. Follow the procedure listed in the [Before working inside your system](#).
3. [Remove the drive backplane cover](#).
4. [Remove the side wall bracket](#).

### Steps

1. Align and slide the right control panel into the slot on the system.
2. Route the right control panel cable through the side wall of the system.
3. Align and slide the right control panel cable cover in the slot on the system.

**NOTE:** Route the cable properly to prevent the cable from being pinched or crimped.

4. Connect the right control panel cable and VGA cable to the connectors on the system board.
5. Using the Phillips 1 screwdriver, tighten the screws that secure the right control panel and the cable cover to the system.

**NOTE:** The numbers on the image do not depict the exact steps. The numbers are for representation of sequence.

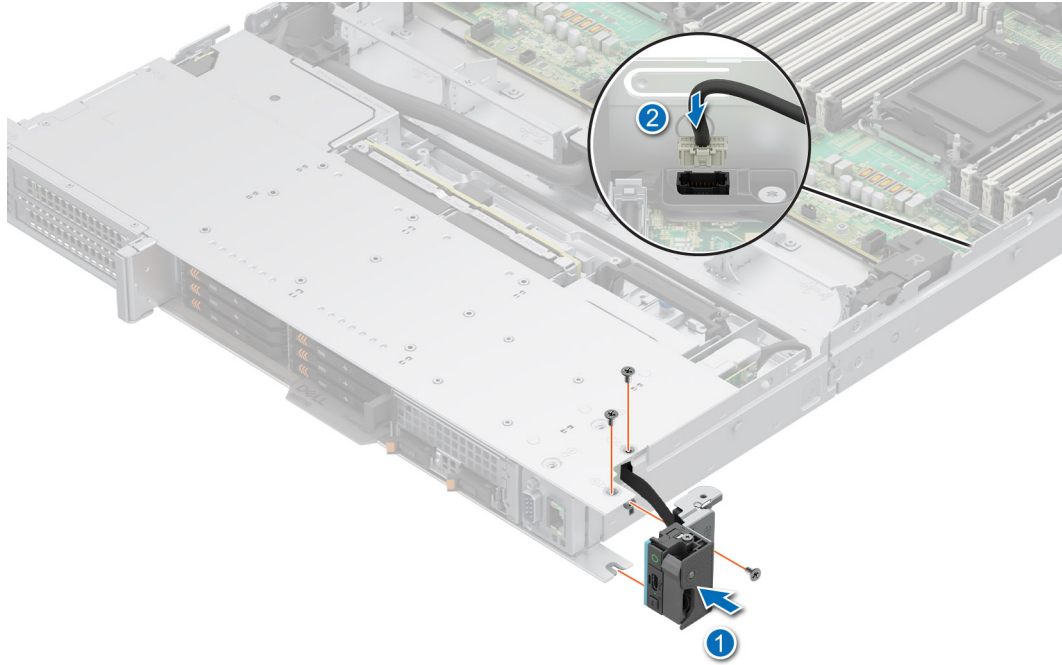

**Figure 260. Installing the right control panel**

### Next steps

1. [Install the side wall bracket.](#)
2. [Install the drive backplane cover.](#)
3. Follow the procedure listed in [After working inside your system.](#)

## Removing the KVM left control panel

### Prerequisites

1. Follow the safety guidelines listed in the [Safety instructions.](#)
2. Follow the procedure listed in the [Before working inside your system.](#)
3. [Remove the drive backplane cover.](#)
4. [Remove the side wall bracket.](#)

### Steps

1. Disconnect the control panel cable from the connector on the system board.
2. Using the Phillips 1 screwdriver, remove the screws that secure the KVM left control panel and the cable cover to the system.
3. Remove the cable cover away from the system.
4. Holding the cable, slide the KVM left control panel out of the system.

**NOTE:** Observe the routing of the cable as you remove the KVM left control panel from the system.

**NOTE:** The numbers on the image do not depict the exact steps. The numbers are for representation of sequence.

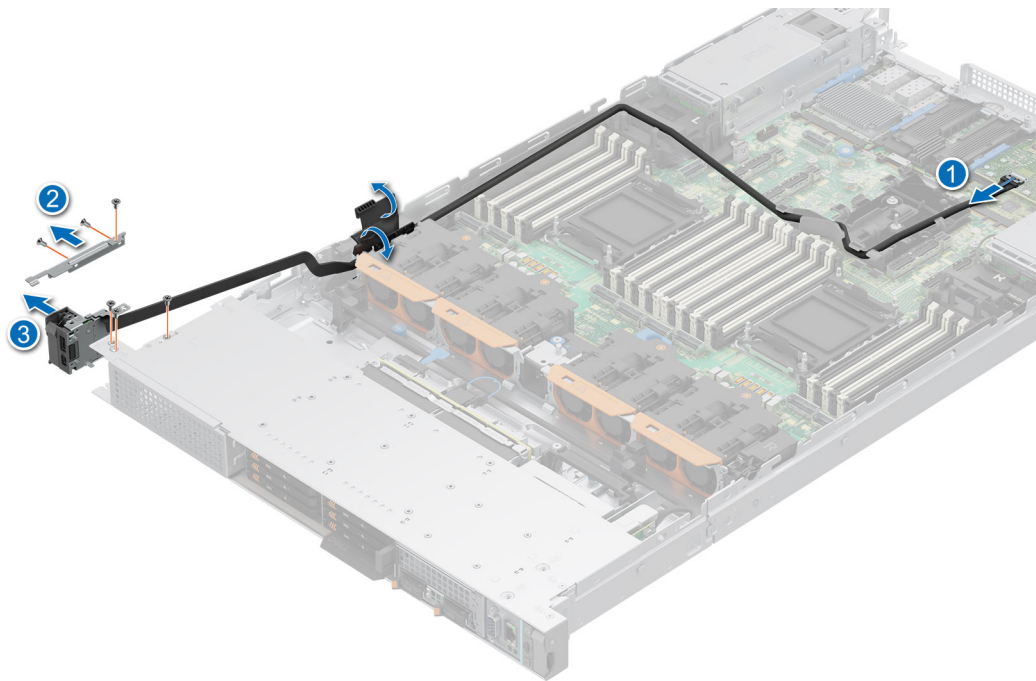

Figure 261. Removing the KVM left control panel

#### Next steps

1. [Replace the KVM left control panel.](#)

## Installing the KVM left control panel

#### Prerequisites

1. Follow the safety guidelines listed in the [Safety instructions](#).
2. Follow the procedure listed in the [Before working inside your system](#).
3. [Remove the drive backplane cover.](#)
4. [Remove the side wall bracket.](#)

#### Steps

1. Align and slide the KVM left control panel in the slot on the system.
2. Route the KVM left control panel cable through the side wall of the system.
3. Align and slide the KVM left control panel cable cover in the slot on the system.

**NOTE:** Route the cable properly to prevent the cable from being pinched or crimped.

4. Connect the KVM left control panel cable to the connector on the system board .
5. Using the Phillips 1 screwdriver, tighten the screws to secure the KVM left control panel and the cable cover to the system.

**NOTE:** The numbers on the image do not depict the exact steps. The numbers are for representation of sequence.

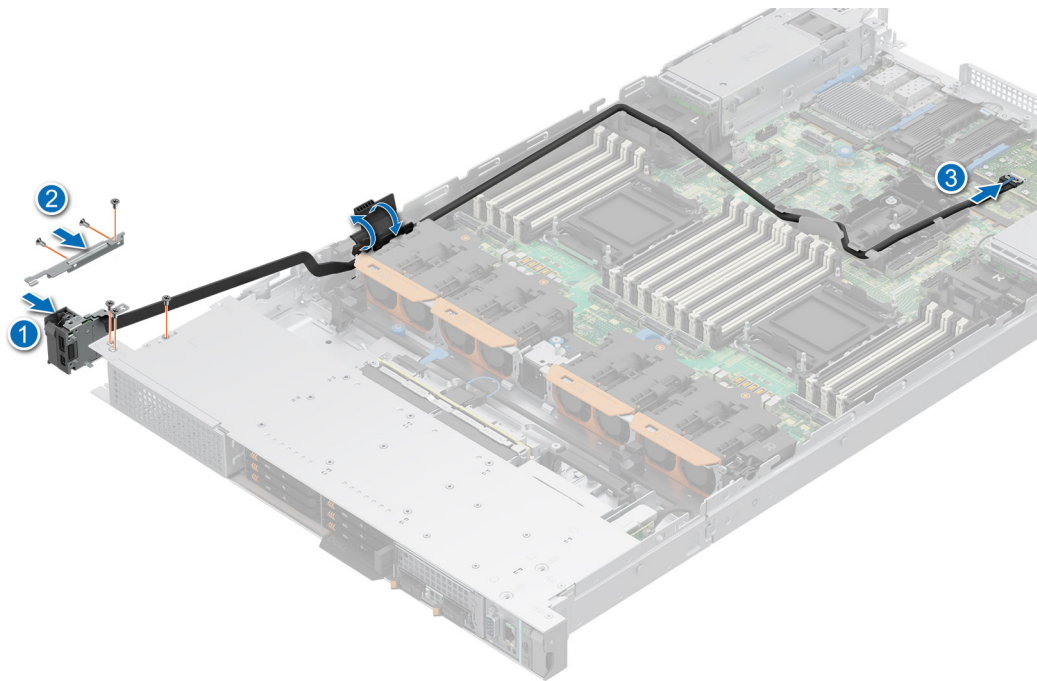

**Figure 262. Installing the KVM left control panel**

**Next steps**

1. [Install the side wall bracket.](#)
2. [Install the drive backplane cover.](#)
3. Follow the procedure listed in [After working inside your system.](#)

## Upgrade Kits

The table lists the available After Point Of Sale [APOS] kits.

**Table 90. Upgrade kits**

Kits	Related links to service instructions
Memory	See <a href="#">Installing a memory module</a>
SSD	See <a href="#">Installing a drive</a>
Processor	See <a href="#">Installing a processor</a>
Power supplies	See <a href="#">Installing a power supply unit</a>
Cables	See <a href="#">Cable routing</a>

### Topics:

- [Processor upgrade guidelines](#)

## Processor upgrade guidelines

### Procedure to clear NVRAM and switch between Intel® Xeon® E-Core processor and Intel® Xeon® P-core processor

1. Before the processor upgrade, ensure that the system has been upgraded to the latest BIOS, iDRAC, and FPGA version. See [Processor specifications](#) for more details.
2. Power off the system and follow the below steps to clear the NVRAM
  - a. Remove the power cords from all the power supply units.
  - b. Remove the [system cover](#), [air shrouds](#), and all the [rear risers](#)(if applicable).
  - c. Replace the Intel® Xeon® E-Core processor with the Intel® Xeon® P-core processor. For information on removal and installation procedure for processor, see [Processor and heat sink](#).
  - d. Toggle the DIP switch 1 to 'ON' state as shown below. For the DIP switch location on the HPM board see, [System board connectors and DIP switches](#).

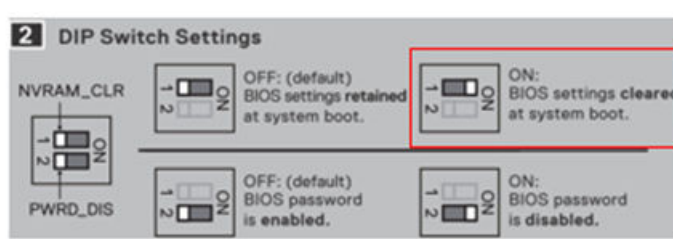

**Figure 263. Image showing the 'ON' state**

- e. Install the [system cover](#), [the air shrouds](#), and all the [rear risers](#)(if applicable).
- f. Connect the power cords to the power supply units, and power on the system.
- g. When the system displays the **UEFI0033** message on the BIOS post screen as below, power off the system and disconnect the power cords from the all the power supply units.

```
UEFI0033: Default system BIOS settings are in use because a NVRAM_CLR request
was issued by the remote user.
To change the system BIOS settings and persistently save the settings, go to
the System Setup to configure system settings.
```

**Figure 264. BIOS POST screen**

- h. Remove the [system cover](#), [air shrouds](#), and all the [rear risers](#)(if applicable).
- i. Toggle the DIP switch 1 to “Off” state as shown below. For the DIP switch location on the HPM board see [System board connectors and DIP switches](#).

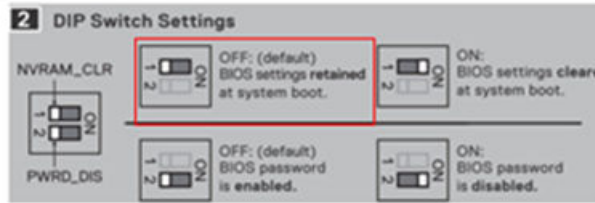

**Figure 265. Image showing the 'OFF' state**

- j. Install the [system cover](#), [the air shrouds](#), and all the [rear risers](#)(if applicable).
- k. Connect the power cords to all the power supply units, power on the system and boot normally.

**NOTE:** The process is the same when replacing an Intel® Xeon® P-Core processor with an Intel® Xeon® E-core processor.

# System diagnostics and indicator codes

The diagnostic indicators on the system front panel display system status during system startup.

## Topics:

- [Power button LED](#)
- [System health and system ID indicator codes](#)
- [iDRAC Direct LED indicator codes](#)
- [NIC indicator codes](#)
- [Power supply unit indicator codes](#)
- [EDSFF E3.S drive led codes](#)
- [Using system diagnostics](#)

## Power button LED

The power button LED is on the front panel of your system.



Figure 266. Power button LED

Table 91. Power button LED

Power button LED indicator code	Condition
Off	System is not operating, regardless of the power supply available.
On	System is operating, one or more of the non-standby power supply units are active.
Slowly blinking	System is performing powering on sequence, and is still booting.

# System health and system ID indicator codes

The system health and system ID indicator is located on the right control panel of the system.



Figure 267. System health and system ID indicator

Table 92. System health and system ID indicator codes

System health and system ID indicator code	Condition
Solid blue	Indicates that the system is powered on, is healthy, and system ID mode is not active. Press the system ID button to switch to system ID mode.
Blinking blue	Indicates that the system ID mode is active. Press the system ID button to switch to system health mode.
Blinking amber	Indicates that the system is experiencing a fault. Check the System Event Log for specific error messages. <a href="#">EEMI guide</a>

## iDRAC Direct LED indicator codes

The iDRAC Direct LED indicator lights up to indicate that the port is connected and is being used as a part of the iDRAC subsystem.

You can configure iDRAC Direct by using a USB to Type C cable, which you can connect to your laptop or tablet. Cable length should not exceed 3 feet (0.91 meters). Performance could be affected by cable quality. The following table describes iDRAC Direct activity when the iDRAC Direct port is active:

Table 93. iDRAC Direct LED indicator codes

iDRAC Direct LED indicator code	Condition
Solid green for two seconds	Indicates that the laptop or tablet is connected.
Blinking green (on for two seconds and off for two seconds)	Indicates that the laptop or tablet that is connected is recognized.
LED Indicator off	Indicates that the laptop or tablet is unplugged.

## NIC indicator codes

Each NIC on the back of the system has indicators that provide information about the activity and link status. The activity LED indicator indicates if data is flowing through the NIC, and the link LED indicator indicates the speed of the connected network.

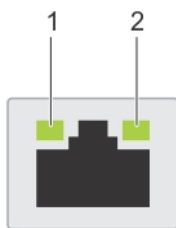

**Figure 268. NIC indicator codes**

1. Link LED indicator
2. Activity LED indicator

**Table 94. NIC indicator codes**

NIC indicator codes	Condition
Link and activity indicators are off.	Indicates that the NIC is not connected to the network.
Link indicator is green, and activity indicator is blinking green.	Indicates that the NIC is connected to a valid network at its maximum port speed, and data is being sent or received.
Link indicator is amber, and activity indicator is blinking green.	Indicates that the NIC is connected to a valid network at less than its maximum port speed, and data is being sent or received.
Link indicator is green, and activity indicator is off.	Indicates that the NIC is connected to a valid network at its maximum port speed, and data is not being sent or received.
Link indicator is amber, and activity indicator is off.	Indicates that the NIC is connected to a valid network at less than its maximum port speed, and data is not being sent or received.
Link indicator is blinking green, and activity is off.	Indicates that the NIC identity is enabled through the NIC configuration utility.

## Power supply unit indicator codes

AC power supply units (PSUs) have an illuminated translucent handle that serves as an indicator. The indicator shows if power is present or if a power fault has occurred.

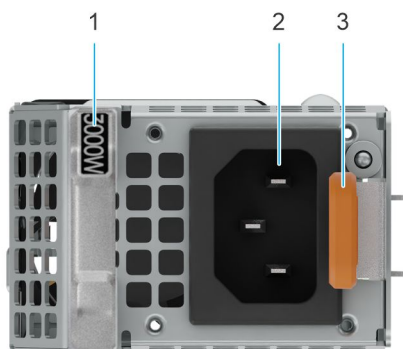

**Figure 269. AC PSU status indicator**

1. AC PSU handle
2. Socket
3. Release latch

**Table 95. AC PSU status indicator codes**

Power indicator codes	Condition
Green	Indicates that a valid power source is connected to the PSU and the PSU is operational.
Blinking amber	Indicates an issue with the PSU.
Not powered on	Indicates that the power is not connected to the PSU.
Blinking green	Indicates that the firmware of the PSU is being updated. <b>CAUTION: Do not disconnect the power cord or unplug the PSU when updating firmware. If firmware update is interrupted, the PSUs will not function.</b>
Blinking greens and powers off	When hot-plugging a PSU, it blinks green five times at a rate of 4 Hz and powers off. This indicates a PSU mismatch due to efficiency, feature set, health status, or supported voltage. <b>CAUTION: If two PSUs are installed, both the PSUs must have the same type of label; for example, Extended Power Performance (EPP) label. Mixing PSUs from previous generations of PowerEdge servers is not supported, even if the PSUs have the same power rating. This results in a PSU mismatch condition or failure to power on the system.</b> <b>CAUTION: If two PSUs are used, they must be of the same type and have the same maximum output power.</b> <b>CAUTION: When correcting a PSU mismatch, replace the PSU with the blinking indicator. Swapping the PSU to make a matched pair can result in an error condition and an unexpected system shutdown. To change from a high output configuration to a low output configuration or vice versa, you must power off the system.</b> <b>CAUTION: AC PSUs support both 240 V and 120 V input voltages with the exception of Titanium PSUs, which support only 240 V. When two identical PSUs receive different input voltages, they can output different wattages, and trigger a mismatch.</b>

## EDSFF E3.S drive led codes

The LEDs on the drive carrier indicate the state of each drive. The LEDs on the EDSFF E3.S drive have two LEDs: an activity LED (green) and a locate/fault LED (blue/amber). The activity LED blinks whenever the drive is accessed.



**Figure 270. EDSFF E3.S drive indicators**

1. Drive activity LED indicator
2. Drive status LED indicator
3. Drive capacity label

## EDSFF E3.S drive led codes

E3.S hard drives have Green LED and Blue/Amber LED.

- Green LED shows : Drive power status , Activity
- Blue/Amber LED shows: Drive Fault, Locate

EDSFF indicator behavior

**Table 96. EDSFF indicator behavior**

Pattern Name	Description	Blue Element	Amber Element
Locate	This device is being identified.	ON (1 sec ON 1 sec OFF)	OFF
Fault	The device is in a fault condition.	OFF	ON (2 sec ON 1 sec OFF)
N/A	This device does not have fault or locate device.	OFF	OFF

**NOTE:** Locate behavior overrides Fault state.

Green LED

The green LED is driven and controlled by the device. The two functions for this LED are defined as follows:

- Power: This function indicates that the device has power and has no issues with its power regulation. Once the green LED is ON, it shall either remain ON or blink at the activity frequency unless the device determines power is no longer within its operating range.
- Activity: This function indicates if the device is being used.

**Table 97. LED and device state per function for Green LED**

Function/Device state	LED state
Power ON/Device is powered, no activity occurring.	ON
Activity/Device is powered, host initiated I/O activity occurring.	4 Hz nominal blink rate
Power OFF/Device is not powered.	OFF

## Using system diagnostics

If you experience an issue with the system, run the system diagnostics before contacting Dell for technical assistance. The purpose of running system diagnostics is to test the system hardware without using additional equipment or risking data loss. If you are unable to fix the issue yourself, service and support personnel can use the diagnostics results to help you solve the issue.

## Dell Embedded System Diagnostics

**NOTE:** The Dell Embedded System Diagnostics is also known as Enhanced Pre-boot System Assessment (ePSA) diagnostics.

The Embedded System Diagnostics provide a set of options for particular device groups or devices allowing you to:

- Run tests automatically or in an interactive mode
- Repeat tests
- Display or save test results
- Run thorough tests to introduce additional test options to provide extra information about the failed device(s)
- View status messages that inform you if tests are completed successfully
- View error messages that inform you of issues encountered during testing

## Run the Embedded System Diagnostics from Boot Manager

Run the Embedded System Diagnostics (ePSA) if your system does not boot.

### Steps

1. When system boots, press **F11**.
2. Select **Hardware Diagnostics** → **Run Hardware Diagnostics**.

## System diagnostic controls

**Table 98. System diagnostic controls**

Menu	Description
<b>Configuration</b>	Displays the configuration and status information of all detected devices.
<b>Results</b>	Displays the results of all tests that are run.
<b>System health</b>	Provides an overview of the system performance.
<b>Event log</b>	Displays a time-stamped log of test results. This displays if at least one event description is recorded.

# HPM board connectors and DIP Switches

This topic provides some basic and specific information about DIP switches. DIP switches on the HPM board help to disable the system and reset the passwords. To set the switches correctly, you must know the location on the HPM board. .

**Topics:**

- System board connectors and DIP switches
- DIP switch settings
- Disable a password

## System board connectors and DIP switches

System board connectors and DIP switches are provided.

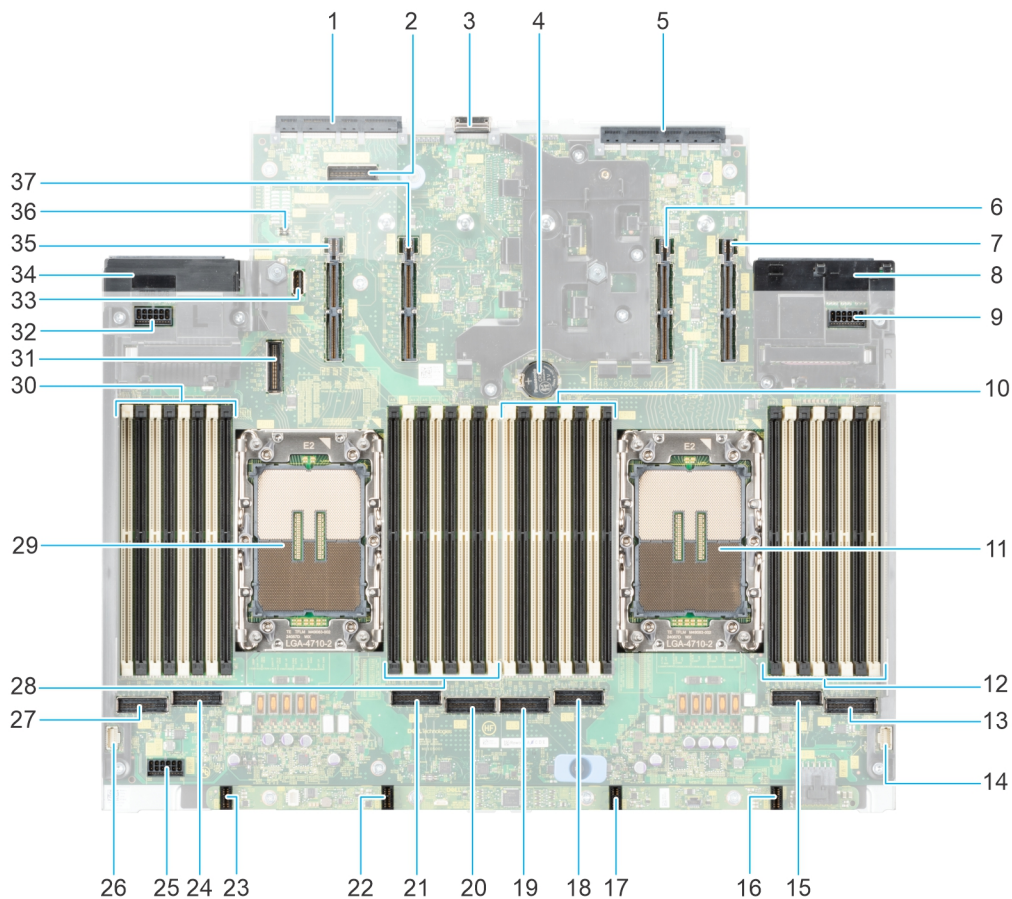

Figure 271. System board connectors and DIP switches

Table 99. System board jumpers and connectors descriptions

Item	Connector
1.	OCP NIC 3.0 Connector
2.	PCIe Connector 21 (SL21_CPU0_PA5)

**Table 99. System board jumpers and connectors descriptions (continued)**

<b>Item</b>	<b>Connector</b>
3.	BOSS Connector
4	Coin cell battery
5.	DC-SCM Connector
6.	Riser 2 slot (R2f): Riser Connector 2 - Requires CPU 1 (SL17/SL18/PWR17/PWR18)
7.	Riser 2 slot (R2b): Riser Connector 1 - Requires CPU 1 (SL19/SL20/PWR19/PWR20)
8.	PSU Connector 2
9.	Power Connector 23/ 24 (PWR23/PWR24)
10.	Memory slots for Processor 0: B8, B16, B4, B12, B6, B14, B2, B10
11.	Processor 0
12.	Memory slots for Processor 0: B9, B1, B13, B5, B11, B3, B15, B7
13.	PCIe Connector 8 (SL8_CPU1_PA4)
14.	Primary Control Panel Connector
15.	PCIe Connector 7 (SL7_CPU1_PB4)
16.	Fan 4
17.	Fan 3
18.	PCIe Connector 6 (SL6_CPU1_PB3)
19.	PCIe Connector 5 (SL5_CPU1_PA3)
20.	PCIe Connector 4 (SL4_CPU0_PA2)
21.	PCIe Connector 3 (SL3_CPU0_PB2)
22.	Fan 2
23.	Fan 1
24.	PCIe Connector 2 (SL2_CPU0_PB1)
25.	Power Connector 1/ 2 (PWR1/PWR2)
26.	Secondary Control Panel Connector
27.	PCIe Connector 1 (SL1_CPU0_PA1)
28.	Memory slots for Processor 1: A9, A1, A13, A5, A11, A3, A15, A7
29.	Processor 1
30.	Memory slots for Processor 1: A8, A16, A4, A12, A6, A14, A2, A10
31.	PCIe Connector 9 (SL9_CPU0_PA5)
32.	Power Connector 5/ 6 (PWR5/PWR6)
33.	Internal USB
34.	PSU Connector 1
35.	Riser Connector 5 - Requires CPU 0 (SL11/SL12/PWR11/PWR12)
36.	DIP Switch for NVRAM/PWRD
37.	Riser Connector 4 - Requires CPU 0 (SL13/SL14/PWR13/PWR14)

# DIP switch settings

To reset the password, see the *Disable a forgotten password*.

**Table 100. DIP Switch settings**

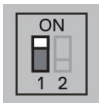
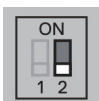
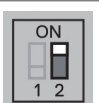
Jumper	Setting	Description
NVRAM_CLR		OFF (default): The BIOS settings are retained at system boot.
		ON: The BIOS settings cleared at system boot.
PWRD_DIS		OFF (default): The BIOS password is enabled.
		ON: The BIOS password is disabled.

The BIOS interface is designed for advanced users.

**CAUTION:** Be cautious when changing BIOS settings. Any changes in the setting may prevent your system from starting correctly and may even result in data loss.

## Disable a password

The password DIP switch enables or disables password features and clears any passwords in use.

### Prerequisites

**CAUTION:** Many repairs may only be done by a certified service technician. You should only perform troubleshooting and simple repairs as authorized in your product documentation, or as directed by the online or telephone service and support team. Damage due to servicing that is not authorized by Dell is not covered by your warranty. Read and follow the safety instructions that are shipped with your product.

### Steps

1. Power off the system and all attached peripherals. Disconnect the system from the electrical outlet, and disconnect the peripherals.
2. [Remove the system cover.](#)
3. Move the DIP switch on the system board from switches and use a plastic scribe to change the DIP switch settings.
4. [Remove the system cover.](#)  
If you assign a new system and/or setup password with the jumper on pins 4 and 6, the system disables the new password the next time it boots.
5. Reconnect the peripherals and connect the system to the electrical outlet. Power on the system.
6. Power off the system.
7. [Remove the system cover.](#)
8. Move the DIP switch on the system board from switches 1 and 2 to switches 2 and 3.
9. [Remove the system cover.](#)
10. Reconnect the peripherals and connect the system to the electrical outlet. Power on the system.
11. Assign a new system set up the password.

# Getting Help

## Topics:

- [Recycling or End-of-Life service information](#)
- [Contact Dell Technologies](#)
- [Accessing system information by using MyDell](#)
- [Receiving automated support with Secure Connect Gateway \(SCG\)](#)

## Recycling or End-of-Life service information

Take back and recycling services are offered for this product in certain countries. If you want to dispose of system components, visit [How to Recycle](#) and select the relevant country.

## Contact Dell Technologies

Dell provides online support, mobile support, and onsite service options. If you do not have an active Internet connection, you can find Dell contact information on your invoice, packing slip, bill, or Dell product catalog. The availability of services varies depending on the country or region and product, and some services may not be available in your area. You can contact Dell for sales, technical support, or customer service issues.

### Steps

1. Go to [Dell Support](#) and follow the prompts.
2. For contact details of Dell Global Technical Support, click [Contact Technical Support](#).

## Accessing system information by using MyDell

You can use the MyDell label located on the Express service tag in the front of the PowerEdge system, to access information about PowerEdge R670 system.

### Prerequisites

Ensure that your smartphone or tablet has a QR code scanner installed.

The MyDell includes the following information about your system:

- How-to videos
- Reference materials, including the Installation and Service Manual, and mechanical overview.
- The system service tag to quickly access the specific hardware configuration and warranty information.
- A direct link to Dell to contact technical support and sales teams.

### Steps

Go to product-specific page in [PowerEdge Manuals](#) or scan the model-specific QR code on your system using your smartphone or tablet.

## QR code for PowerEdge R670 system resources

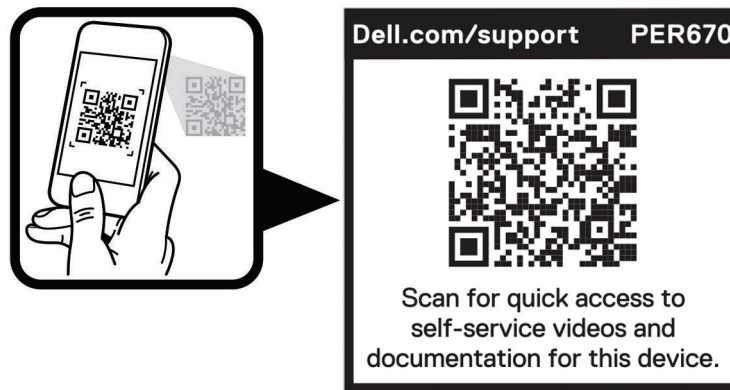

Figure 272. QR code for PowerEdge R670 system

## Receiving automated support with Secure Connect Gateway (SCG)

Dell Secure Connect Gateway (SCG) is an optional Dell Services offering that automates technical support for your Dell server, storage, and networking devices. By installing and setting up a Secure Connect Gateway (SCG) application in your IT environment, you can receive the following benefits:

- Automated issue detection — Secure Connect Gateway (SCG) monitors your Dell devices and automatically detects hardware issues, both proactively and predictively.
- Automated case creation — When an issue is detected, Secure Connect Gateway (SCG) automatically opens a support case with Dell Technical Support.
- Automated diagnostic collection — Secure Connect Gateway (SCG) automatically collects system state information from your devices and uploads it securely to Dell. This information is used by Dell Technical Support to troubleshoot the issue.
- Proactive contact — A Dell Technical Support agent contacts you about the support case and helps you resolve the issue.

The available benefits vary depending on the Dell Service entitlement purchased for your device. For more information about Secure Connect Gateway (SCG), go to [secureconnectgateway](https://www.dell.com/support/secureconnectgateway).

## Documentation resources

This section provides information about the documentation resources for your system.

To view the document that is listed in the documentation resources table:

- From the Dell support site:
  1. Click the documentation link that is provided in the Location column in the table.
  2. Click the required product or product version.

 **NOTE:** To locate the model number, see the front of your system.

3. On the Product Support page, click **Documentation**.
- Using search engines:
    - Type the name and version of the document in the search box.

**Table 101. Additional documentation resources for your system**

Task	Document	Location
Setting up your system	<p>For more information about installing and securing the system into a rack, see the Rail Installation Guide included with your rail solution.</p> <p>For information about setting up your system, see the <i>Quick Start Guide</i></p>	<a href="#">PowerEdge manuals</a>
Configuring your system	<p>For information about the iDRAC features, configuring and logging in to iDRAC, and managing your system remotely, see the Integrated Dell Remote Access Controller User's Guide.</p> <p>For information about understanding Remote Access Controller Admin (RACADM) subcommands and supported RACADM interfaces, see the RACADM CLI Guide for iDRAC .</p> <p>For information about Redfish and its protocol, supported schema, and Redfish Eventing implemented in iDRAC, see the Redfish API Guide.</p> <p>For information about iDRAC property database group and object descriptions, see the Attribute Registry Guide.</p>	<a href="#">PowerEdge manuals</a>
	<p>For information about earlier versions of the iDRAC documents.</p> <p>To identify the version of iDRAC available on your system, on the iDRAC web interface, click <b>? &gt; About</b>.</p>	<a href="#">iDRAC Manuals</a>
	<p>For information about installing the operating system, see the operating system documentation.</p>	<a href="#">Operating System Manuals</a>

**Table 101. Additional documentation resources for your system (continued)**

<b>Task</b>	<b>Document</b>	<b>Location</b>
	For information about updating drivers and firmware, see the Methods to download firmware and drivers section in this document.	<a href="#">Drivers</a>
Managing your system	For information about installing and using Dell Secure Connect Gateway, see the Dell Secure Connect Gateway Enterprise User's Guide.	<a href="#">serviceability tools</a>
Working with the Dell PowerEdge RAID controllers (if applicable)	For information about understanding the features of the Dell PowerEdge RAID controllers (PERC), Software RAID controllers, or BOSS card and deploying the cards, see the Storage controller documentation.	<a href="#">Storage Controller Manuals</a>
Understanding event and error messages	For information about the event and error messages generated by the system firmware and agents that monitor system components, see the EEMI guide.	<a href="#">EEMI guide</a>
Troubleshooting your system	For information about identifying and troubleshooting the PowerEdge server issues, see the Server Troubleshooting Guide.	<a href="#">PowerEdge manuals</a>