

Dell PowerEdge R7725

Installation and Service Manual

Notes, cautions, and warnings

 **NOTE:** A NOTE indicates important information that helps you make better use of your product.

 **CAUTION:** A CAUTION indicates either potential damage to hardware or loss of data and tells you how to avoid the problem.

 **WARNING:** A WARNING indicates a potential for property damage, personal injury, or death.

Chapter 1: Introduction.....	8
Chapter 2: PowerEdge R7725 system configurations and features.....	9
System configurations - front view for PowerEdge R7725 system.....	10
System configurations - rear view for PowerEdge R7725 system.....	22
System configurations - inside view for PowerEdge R7725 system.....	24
Locating the Express Service Code and Service Tag.....	29
System information label.....	30
Rail sizing and rack compatibility matrix.....	33
Chapter 3: Technical specifications.....	34
Chassis dimensions	35
System weight.....	35
Processor specifications.....	36
PSU specifications.....	36
Cooling fan specifications.....	38
Supported operating systems.....	40
System battery specifications.....	40
Expansion card riser specifications.....	40
Memory specifications.....	40
Storage controller specifications.....	41
Drives.....	41
GPU Specifications.....	42
DPU Specifications.....	42
Ports and connectors specifications.....	42
NIC port specifications.....	42
USB ports specifications.....	43
VGA ports specifications.....	43
Video specifications.....	43
Environmental specifications.....	43
Particulate and gaseous contamination specifications.....	45
Thermal restriction matrix.....	46
Thermal air restrictions.....	53
Chapter 4: Initial system setup and configuration.....	56
Setting up the system.....	56
iDRAC configuration.....	56
Set up iDRAC IP address.....	56
Log in to iDRAC.....	57
Install an operating system.....	57
Options to download drivers and firmware	57
Options to download and install OS drivers	57
Downloading drivers and firmware.....	58

Chapter 5: Pre-operating system management applications.....	59
System Setup.....	59
System BIOS.....	60
Dell Open Server Manager Settings.....	60
Device Settings.....	60
Boot Manager.....	60
PXE boot.....	60
 Chapter 6: Minimum to POST and system management configuration validation.....	 61
Minimum configuration to POST	61
 Chapter 7: Configuration validation.....	 62
 Chapter 8: Installing and removing system components	 63
Safety instructions.....	63
Before working inside your system.....	64
After working inside your system.....	64
Recommended tools.....	64
Optional front metal bezel.....	65
Removing the front bezel.....	65
Installing the front bezel.....	65
System cover.....	66
Removing the system cover.....	66
Installing the system cover.....	67
Air shroud.....	68
Removing the left and right air shrouds.....	68
Installing the left and right air shrouds.....	70
Removing the wing air shroud.....	71
Installing the wing air shroud.....	72
Cooling fans.....	73
Removing a cooling fan.....	73
Installing a cooling fan.....	74
Removing the cooling fan cage assembly	75
Installing the cooling fan cage assembly.....	76
Drive backplane cover.....	77
Removing the drive backplane cover.....	77
Installing the drive backplane cover.....	78
Drives.....	79
Removing a drive blank.....	79
Installing the drive blank.....	80
Removing the drive carrier.....	81
Installing a drive carrier.....	83
Removing the drive from the drive carrier.....	84
Installing the drive into the drive carrier.....	85
Drive backplane.....	86
Drive backplane.....	87
Removing the EDSFF E3.S backplane module.....	88
Installing the EDSFF E3.S backplane module.....	89

Removing the drive backplane	90
Installing the drive backplane.....	91
Side wall brackets.....	92
Removing the side wall bracket.....	92
Installing the side wall bracket.....	94
PERC module.....	96
Removing the front mounting front PERC module.....	96
Installing the front mounting front PERC module.....	97
Removing the PERC H975i module.....	98
Installing the PERC H975i module.....	99
Cable routings.....	102
System memory.....	113
System memory guidelines.....	113
General memory module installation guidelines.....	115
Removing a memory module.....	116
Installing a memory module.....	117
Direct Liquid Cooling (DLC) module mid bracket.....	118
Removing a Direct Liquid Cooling (DLC) mid bracket.....	118
Installing a Direct Liquid Cooling (DLC) mid bracket.....	120
Processor and heat sink.....	122
Removing the heat sink module.....	122
Removing the Direct Liquid Cooling (DLC) module.....	123
Removing the processor.....	124
Installing the processor.....	126
Installing the heat sink module.....	128
Installing the Direct Liquid Cooling (DLC) module.....	129
Expansion cards and expansion card risers.....	130
Expansion card installation guidelines	131
Removing the rear expansion card risers.....	141
Installing the rear expansion card risers.....	143
Removing the dual-width GPU.....	146
Installing the dual-width GPU.....	150
Removing an expansion card from the expansion card riser.....	153
Installing an expansion card into the expansion card riser.....	159
Removing the expansion card riser blanks.....	165
Installing the expansion card riser blanks.....	167
M.2 SSD module.....	169
Removing the M.2 NVMe SSD module.....	169
Installing the M.2 NVMe SSD module.....	171
Optional BOSS-N1 DC-MHS module.....	173
Removing the BOSS-N1 DC-MHS controller blank.....	173
Installing the BOSS-N1 DC-MHS controller blank.....	174
Removing the rear BOSS-N1 DC-MHS controller.....	174
Installing the rear BOSS-N1 DC-MHS controller.....	176
Optional OCP NIC card.....	177
Removing the OCP NIC card.....	177
Installing the OCP NIC card.....	179
Datacenter-Secure Control Module (DC-SCM).....	180
Removing the DC-SCM board.....	180
Installing the DC-SCM board.....	181

Attic board.....	182
Removing the Attic board.....	182
Installing the Attic board.....	183
Restoring the system using Easy Restore.....	184
Manually update the Service Tag.....	185
Optional internal USB port.....	185
Replacing the optional internal USB card.....	186
System battery.....	187
Replacing the system battery.....	187
Intrusion switch.....	189
Removing the intrusion switch module.....	189
Installing the intrusion switch module.....	190
Power supply unit.....	191
Hot spare feature.....	191
Removing a power supply unit blank.....	192
Installing a power supply unit blank.....	193
Removing a power supply unit.....	194
Installing a power supply unit.....	194
Removing a power supply unit filler.....	196
Installing a power supply unit filler.....	197
Removing the PSU bracket.....	198
Installing the PSU bracket.....	199
Trusted Platform Module.....	200
Initializing TPM 2.0 for users.....	200
TPM Support.....	200
HPM board.....	200
Removing the HPM board.....	200
Installing the HPM board.....	201
Control panel.....	203
Removing the Right control panel - primary.....	203
Installing the Right control panel - primary.....	204
Removing the Left control panel - secondarywith optional KVM.....	205
Installing the Left control panel - secondary.....	205
Chapter 9: Upgrade Kits.....	207
Processor upgrade kit components.....	207
BOSS-N1 DCMHS module kit.....	208
GPU kit.....	209
Perc module kit.....	209
DPU kit.....	211
Chapter 10: System diagnostics and indicator codes.....	212
Power button LED.....	212
System health and system ID indicator codes.....	213
iDRAC Direct LED indicator codes.....	213
NIC indicator codes.....	214
Power supply unit indicator codes.....	214
Drive indicator codes.....	215
EDSFF E3.S drive led codes.....	216

Using system diagnostics.....	217
Dell Embedded System Diagnostics.....	217
Chapter 11: HPM board connectors and DIP Switches.....	219
HPM board jumpers and connectors.....	219
DIP Switch settings.....	221
Disabling a forgotten password.....	221
Chapter 12: Getting Help.....	223
Recycling or End-of-Life service information.....	223
Contact Dell Technologies.....	223
Accessing system information by using MyDell.....	223
MyDell label for PowerEdge R7725 system resources.....	224
Receiving automated support with Secure Connect Gateway (SCG).....	224
Chapter 13: Documentation resources.....	225

Introduction

This document provides a system overview, information about installing and replacing components, diagnostic tools, and guidelines for installing certain components.

Recycling or End-of-Life service information

Take back and recycling services are offered for this product in certain countries. If you want to dispose of system components, go to [How to Recycle](#) and select the relevant country or region.

Automated support with secure connect gateway

Secure connect gateway is an optional Services offering that automates technical support for your server, storage, and networking devices. A secure connect gateway in your IT environment provides the following benefits:

- Automated issue detection: Monitors your devices and detects hardware issues.
- Automated case creation: Detects issues and opens a support case with Technical Support.
- Automated diagnostic collection: Collects system state information and uploads it securely to Dell Support. This information is used by Technical Support to troubleshoot the issue.
- Proactive contact: Technical Support agents contacts you about the support case.

The available benefits vary depending on the Service entitlement that is purchased for your device. For more information about secure connect gateway, go to [secureconnectgateway](#).

PowerEdge R7725 system configurations and features

The PowerEdge R7725 system is a 2U server that supports:

- Two 5th Generation AMD EPYC 9005 Series processors with up to 192 cores per processor.
- Optional Direct Liquid Cooling (DLC) for required CPU SKU and/or configurations
- 24 DIMM slots
- Two redundant AC or DC power supply units
- No backplane configuration
- Up to 8 x 2.5-inch Universal
- Up to 12 x 3.5-inch SAS/SATA
- Up to 16 x 2.5-inch SAS/SATA
- Up to 24 x 2.5-inch SAS/SATA
- Up to 16 x 2.5-inch SAS/SATA + 8 x U.2 or 2.5-inch NVMe RAID
- Up to 8 x EDSFF E3.S Gen5 NVMe
- Up to 16 x EDSFF E3.S Gen5 NVMe
- Up to 32 x EDSFF E3.S Gen5 NVMe
- Up to 40 x EDSFF E3.S Gen5 NVMe

i **NOTE:** For more information about how to hot swap NVMe PCIe SSD device, see the *Dell Express Flash NVMe PCIe SSD User's Guide* at [Dell Support](#) page > **Browse all products > Infrastructure > Data Center Infrastructure > Storage Adapters & Controllers > Dell PowerEdge Express Flash NVMe PCIe SSD > Select This Product > Documentation > Manuals and Documents.**

i **NOTE:** All instances of SAS, SATA drives are referred to as drives in this document, unless specified otherwise.

i **NOTE:** The system board is known as the Host Processor Module (HPM) board in this document.

△ CAUTION: Do not install GPUs, network cards, or other PCIe devices on your system that are not validated and tested by Dell. Damage caused by unauthorized and invalidated hardware installation will null and void the system warranty.

Topics:

- [System configurations - front view for PowerEdge R7725 system](#)
- [System configurations - rear view for PowerEdge R7725 system](#)
- [System configurations - inside view for PowerEdge R7725 system](#)
- [Locating the Express Service Code and Service Tag](#)
- [System information label](#)
- [Rail sizing and rack compatibility matrix](#)

System configurations - front view for PowerEdge R7725 system



Figure 1. Front view of no backplane configuration

Table 1. Features are available on the front of the system

Item	Ports, panels, and slots	Icon	Description
1	Left Control Panel (LCP) - Secondary	N/A	<p>Contains the USB 2.0 Type-A port (optional LCP - Secondary KVM) and the Mini DisplayPort (optional LCP - Secondary KVM).</p> <ul style="list-style-type: none"> • USB 2.0 Type-A port (optional LCP - Secondary KVM): This port is USB 2.0-compliant with optional LCP - Secondary KVM functions. • Mini DisplayPort: Enables you to connect a display device to the system. <p>NOTE: Use a certified Mini DisplayPort to DisplayPort cable complying with VESA DisplayPort standards for video output with a monitor.</p> <p>NOTE: Mini DisplayPort to VGA or Mini DisplayPort to HDMI adapters are not recommended.</p>
2	Blank panel	N/A	Blank panel to allow air flow for thermal efficiency.
3	Right Control Panel (RCP) - Primary	N/A	Contains the power button, USB 2.0 Type-C port (HOST/BMC Direct), and the system identification button.
4	Express service tag	N/A	The Express service tag is a slide-out label panel that contains system information

Table 1. Features are available on the front of the system (continued)

Item	Ports, panels, and slots	Icon	Description
			such as Service Tag, NIC, MAC address, and so on. If you have opted for the secure default access to iDRAC, the Express service tag also contains the iDRAC secure default password.

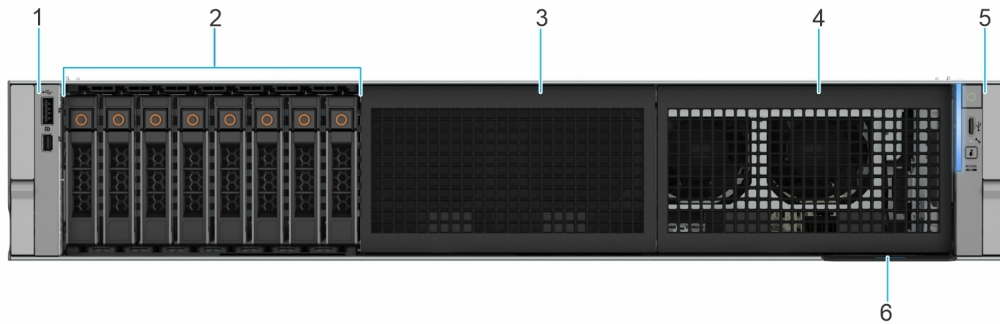

Figure 2. Front view of the 8 x 2.5-inch Universal

Table 2. Features are available on the front of the system

Item	Ports, panels, and slots	Icon	Description
1	Left Control Panel (LCP) - Secondary	N/A	<p>Contains the USB 2.0 Type-A port (optional LCP - Secondary KVM) and the Mini DisplayPort (optional LCP KVM).</p> <ul style="list-style-type: none"> • USB 2.0 Type-A port (optional LCP - Secondary KVM): This port is USB 2.0-compliant with optional LCP - Secondary KVM functions. • Mini DisplayPort: Enables you to connect a display device to the system. <p>i NOTE: Use a certified Mini DisplayPort to DisplayPort cable complying with VESA DisplayPort standards for video output with a monitor.</p> <p>i NOTE: Mini DisplayPort to VGA or Mini DisplayPort to HDMI adapters are not recommended.</p>
2	Drive	N/A	Enables you to install drives that are supported on your system.

Table 2. Features are available on the front of the system (continued)

Item	Ports, panels, and slots	Icon	Description
3	Blank panel	N/A	Blank panel to allow air flow for thermal efficiency.
4	Blank panel	N/A	Blank panel to allow air flow for thermal efficiency.
5	Right Control Panel (RCP) - Primary	N/A	Contains the power button, USB 2.0 Type-C port (HOST/BMC Direct), and the system identification button.
6	Express service tag	N/A	The Express service tag is a slide-out label panel that contains system information such as Service Tag, NIC, MAC address, and so on. If you have opted for the secure default access to iDRAC, the Express service tag also contains the iDRAC secure default password.



Figure 3. Front view of the 12 x 3.5-inch SATA/SAS

Table 3. Features are available on the front of the system

Item	Ports, panels, and slots	Icon	Description
1	Left Control Panel (LCP) - Secondary	N/A	<p>Contains the USB 2.0 Type-A port (optional LCP - Secondary KVM) and the Mini DisplayPort (optional LCP - Secondary KVM).</p> <ul style="list-style-type: none"> • USB 2.0 Type-A port (optional LCP - Secondary KVM): This port is USB 2.0-compliant with optional LCP - Secondary KVM functions. • Mini DisplayPort: Enables you to connect a display device to the system. <p>NOTE: Use a certified Mini DisplayPort to DisplayPort cable complying with VESA DisplayPort standards</p>

Table 3. Features are available on the front of the system (continued)

Item	Ports, panels, and slots	Icon	Description
			<p>for video output with a monitor.</p> <p>NOTE: Mini DisplayPort to VGA or Mini DisplayPort to HDMI adapters are not recommended.</p>
2	Drive	N/A	Enables you to install drives that are supported on your system.
3	Right Control Panel (RCP) - Primary	N/A	Contains the power button, USB 2.0 Type-C port (HOST/BMC Direct), and the system identification button.
4	Express service tag	N/A	The Express service tag is a slide-out label panel that contains system information such as Service Tag, NIC, MAC address, and so on. If you have opted for the secure default access to iDRAC, the Express service tag also contains the iDRAC secure default password.

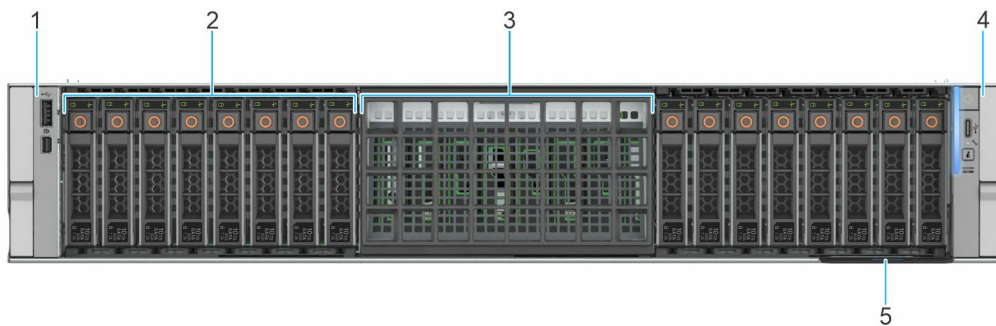

Figure 4. Front view of the 16 x 2.5-inch SAS/SATA

Table 4. Features are available on the front of the system

Item	Ports, panels, and slots	Icon	Description
1	Left Control Panel (LCP) - Secondary	N/A	<p>Contains the USB 2.0 Type-A port (optional LCP - Secondary KVM) and the Mini DisplayPort (optional LCP - Secondary KVM).</p> <ul style="list-style-type: none"> USB 2.0 Type-A port (optional LCP - Secondary KVM): This port is USB 2.0-compliant with optional LCP - Secondary KVM functions.

Table 4. Features are available on the front of the system (continued)

Item	Ports, panels, and slots	Icon	Description
			<ul style="list-style-type: none"> Mini DisplayPort: Enables you to connect a display device to the system. <p>NOTE: Use a certified Mini DisplayPort to DisplayPort cable complying with VESA DisplayPort standards for video output with a monitor.</p> <p>NOTE: Mini DisplayPort to VGA or Mini DisplayPort to HDMI adapters are not recommended.</p>
2	Drive	N/A	Enables you to install drives that are supported on your system.
3	Blank panel	N/A	Blank panel to allow air flow for thermal efficiency.
4	Right Control Panel (RCP) - Primary	N/A	Contains the power button, USB 2.0 Type-C port (HOST/BMC Direct), and the system identification button.
5	Express service tag	N/A	The Express service tag is a slide-out label panel that contains system information such as Service Tag, NIC, MAC address, and so on. If you have opted for the secure default access to iDRAC, the Express service tag also contains the iDRAC secure default password.

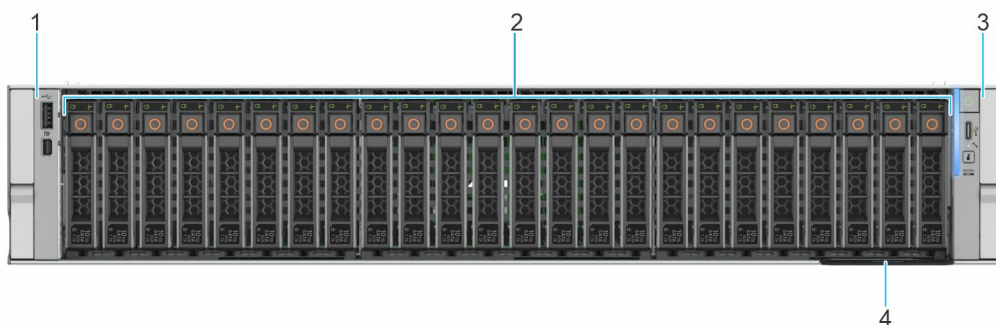

Figure 5. Front view of the 24 x 2.5-inch SAS/SATA

Table 5. Features are available on the front of the system

Item	Ports, panels, and slots	Icon	Description
1	Left Control Panel (LCP) - Secondary	N/A	<p>Contains the USB 2.0 Type-A port (optional LCP - Secondary KVM) and the Mini DisplayPort (optional LCP - Secondary KVM).</p> <ul style="list-style-type: none"> • USB 2.0 Type-A port (optional LCP - Secondary KVM): This port is USB 2.0-compliant with optional LCP - Secondary KVM functions. • Mini DisplayPort: Enables you to connect a display device to the system. <p>NOTE: Use a certified Mini DisplayPort to DisplayPort cable complying with VESA DisplayPort standards for video output with a monitor.</p> <p>NOTE: Mini DisplayPort to VGA or Mini DisplayPort to HDMI adapters are not recommended.</p>
2	Drive	N/A	Enables you to install drives that are supported on your system.
3	Right Control Panel (RCP) - Primary	N/A	Contains the power button, USB 2.0 Type-C port (HOST/BMC Direct), and the system identification button.
4	Express service tag	N/A	The Express service tag is a slide-out label panel that contains system information such as Service Tag, NIC, MAC address, and so on. If you have opted for the secure default access to iDRAC, the Express service tag also contains the iDRAC secure default password.

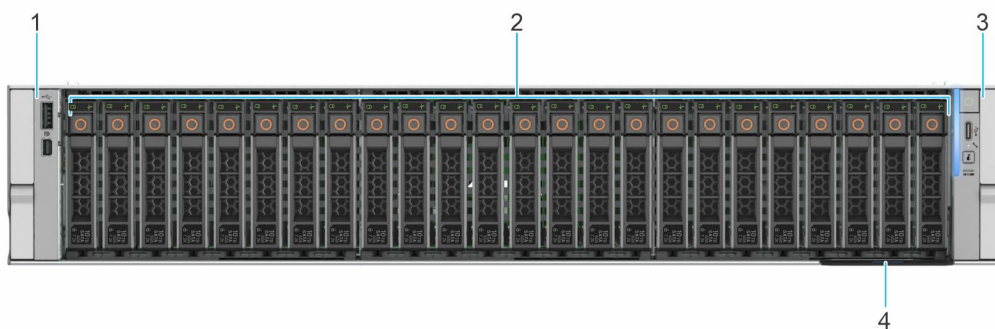

Figure 6. Front view of 16 x 2.5-inch drives + 8 x 2.5-inch U.2 NVMe drive system

Table 6. Features are available on the front of the system

Item	Ports, panels, and slots	Icon	Description
1	Left Control Panel (LCP) - Secondary	N/A	<p>Contains the USB 2.0 Type-A port (optional LCP - Secondary KVM) and the Mini DisplayPort (optional LCP - Secondary KVM).</p> <ul style="list-style-type: none"> • USB 2.0 Type-A port (optional LCP - Secondary KVM): This port is USB 2.0-compliant with optional LCP - Secondary KVM functions. • Mini DisplayPort: Enables you to connect a display device to the system. <p>NOTE: Use a certified Mini DisplayPort to DisplayPort cable complying with VESA DisplayPort standards for video output with a monitor.</p> <p>NOTE: Mini DisplayPort to VGA or Mini DisplayPort to HDMI adapters are not recommended.</p>
2	Drive	N/A	Enables you to install drives that are supported on your system.
3	Right Control Panel (RCP) - Primary	N/A	Contains the power button, USB 2.0 Type-C port (HOST/BMC Direct), and the system identification button.
4	Express service tag	N/A	The Express service tag is a slide-out label panel that contains system information such as Service Tag, NIC, MAC address, and so on. If you have opted for the secure default access to iDRAC,

Table 6. Features are available on the front of the system (continued)

Item	Ports, panels, and slots	Icon	Description
			the Express service tag also contains the iDRAC secure default password.

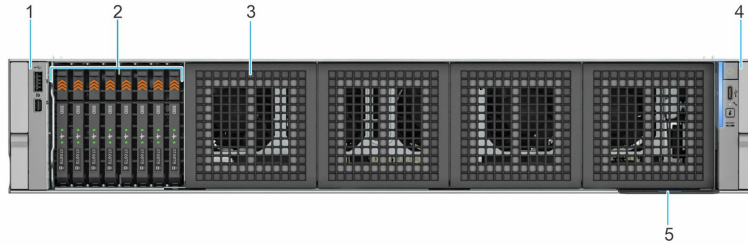

Figure 7. Front view of 8 x EDSFF E3.S NVMe system

Table 7. Features are available on the front of the system

Item	Ports, panels, and slots	Icon	Description
1	Left Control Panel (LCP) - Secondary	N/A	<p>Contains the USB 2.0 Type-A port (optional LCP - Secondary KVM) and the Mini DisplayPort (optional LCP - Secondary KVM).</p> <ul style="list-style-type: none"> • USB 2.0 Type-A port (optional LCP - Secondary KVM): This port is USB 2.0-compliant with optional LCP - Secondary KVM functions. • Mini DisplayPort: Enables you to connect a display device to the system. <p>NOTE: Use a certified Mini DisplayPort to DisplayPort cable complying with VESA DisplayPort standards for video output with a monitor.</p> <p>NOTE: Mini DisplayPort to VGA or Mini DisplayPort to HDMI adapters are not recommended.</p>
2	Drive	N/A	Enables you to install drives that are supported on your system.
3	Blank Panel	N/A	Enables you to install drives that are supported on your system.
4	Right Control Panel (RCP) - Primary	N/A	Contains the power button, USB 2.0 Type-C port

Table 7. Features are available on the front of the system (continued)

Item	Ports, panels, and slots	Icon	Description
			(HOST/BMC Direct), and the system identification button.
5	Express service tag	N/A	The Express service tag is a slide-out label panel that contains system information such as Service Tag, NIC, MAC address, and so on. If you have opted for the secure default access to iDRAC, the Express service tag also contains the iDRAC secure default password.

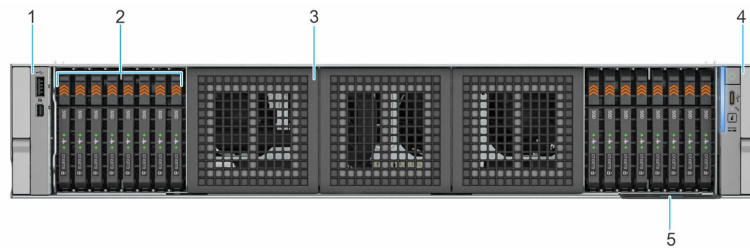

Figure 8. Front view of 16 x EDSFF E3.S NVMe system

Table 8. Features are available on the front of the system

Item	Ports, panels, and slots	Icon	Description
1	Left Control Panel (LCP) - Secondary	N/A	<p>Contains the USB 2.0 Type-A port (optional LCP - Secondary KVM) and the Mini DisplayPort (optional LCP - Secondary KVM).</p> <ul style="list-style-type: none"> • USB 2.0 Type-A port (optional LCP - Secondary KVM): This port is USB 2.0-compliant with optional LCP - Secondary KVM functions. • Mini DisplayPort: Enables you to connect a display device to the system. <p>NOTE: Use a certified Mini DisplayPort to DisplayPort cable complying with VESA DisplayPort standards for video output with a monitor.</p> <p>NOTE: Mini DisplayPort to VGA or Mini DisplayPort to HDMI adapters are not recommended.</p>

Table 8. Features are available on the front of the system (continued)

Item	Ports, panels, and slots	Icon	Description
2	Drive	N/A	Enables you to install drives that are supported on your system.
3	Blank Panel	N/A	Enables you to install drives that are supported on your system.
4	Right Control Panel (RCP) - Primary	N/A	Contains the power button, USB 2.0 Type-C port (HOST/BMC Direct), and the system identification button.
5	Express service tag	N/A	The Express service tag is a slide-out label panel that contains system information such as Service Tag, NIC, MAC address, and so on. If you have opted for the secure default access to iDRAC, the Express service tag also contains the iDRAC secure default password.

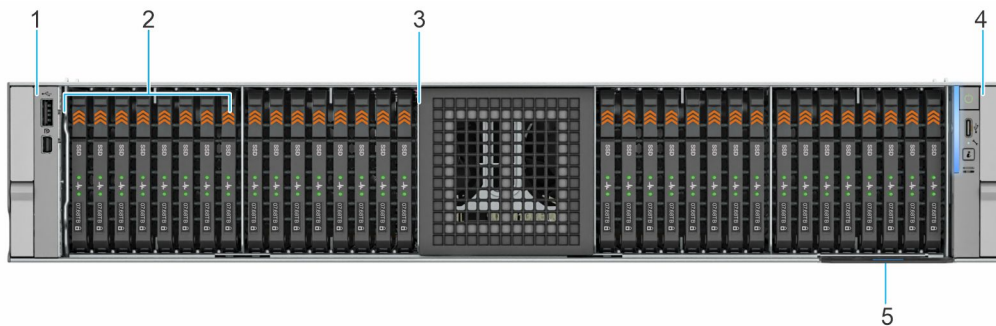

Figure 9. Front view of the 32 x EDSFF E3.S Gen5 NVMe

Table 9. Features are available on the front of the system

Item	Ports, panels, and slots	Icon	Description
1	Left Control Panel (LCP) - Secondary	N/A	<p>Contains the USB 2.0 Type-A port (optional LCP - Secondary KVM) and the Mini DisplayPort (optional LCP - Secondary KVM).</p> <ul style="list-style-type: none"> • USB 2.0 Type-A port (optional LCP - Secondary KVM): This port is USB 2.0-compliant with optional LCP - Secondary KVM functions. • Mini DisplayPort: Enables you to connect a display device to the system. <p>NOTE: Use a certified Mini DisplayPort to DisplayPort cable complying with VESA</p>

Table 9. Features are available on the front of the system (continued)

Item	Ports, panels, and slots	Icon	Description
			<p>DisplayPort standards for video output with a monitor.</p> <p>NOTE: Mini DisplayPort to VGA or Mini DisplayPort to HDMI adapters are not recommended.</p>
2	Drive	N/A	Enables you to install drives that are supported on your system.
3	Blank Panel	N/A	Enables you to install drives that are supported on your system.
4	Right Control Panel (RCP) - Primary	N/A	Contains the power button, USB 2.0 Type-C port (HOST/BMC Direct), and the system identification button.
5	Express service tag	N/A	The Express service tag is a slide-out label panel that contains system information such as Service Tag, NIC, MAC address, and so on. If you have opted for the secure default access to iDRAC, the Express service tag also contains the iDRAC secure default password.

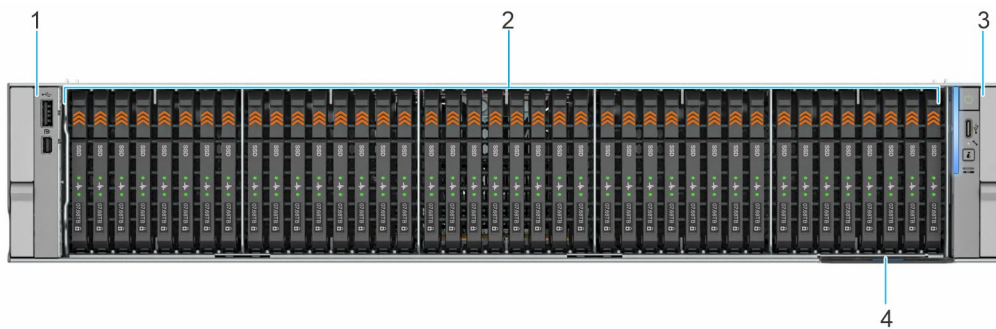

Figure 10. Front view of the 40 x EDSFF E3.S Gen5 NVMe

Table 10. Features are available on the front of the system

Item	Ports, panels, and slots	Icon	Description
1	Left Control Panel (LCP) - Secondary	N/A	<p>Contains the USB 2.0 Type-A port (optional LCP - Secondary KVM) and the Mini DisplayPort (optional LCP - Secondary KVM).</p> <ul style="list-style-type: none"> USB 2.0 Type-A port (optional LCP - Secondary KVM): This port is

Table 10. Features are available on the front of the system (continued)

Item	Ports, panels, and slots	Icon	Description
			<p>USB 2.0-compliant with optional LCP - Secondary KVM functions.</p> <ul style="list-style-type: none"> Mini DisplayPort: Enables you to connect a display device to the system. <p>i NOTE: Use a certified Mini DisplayPort to DisplayPort cable complying with VESA DisplayPort standards for video output with a monitor.</p> <p>i NOTE: Mini DisplayPort to VGA or Mini DisplayPort to HDMI adapters are not recommended.</p>
2	Drive	N/A	Enables you to install drives that are supported on your system.
3	Right Control Panel (RCP) - Primary	N/A	Contains the power button, USB 2.0 Type-C port (HOST/BMC Direct), and the system identification button.
4	Express service tag	N/A	The Express service tag is a slide-out label panel that contains system information such as Service Tag, NIC, MAC address, and so on. If you have opted for the secure default access to iDRAC, the Express service tag also contains the iDRAC secure default password.

i **NOTE:** For more information about the ports, see the **Technical Specifications section** in the *Installation and Service Manual* available on the [PowerEdge Manuals](#).

System configurations - rear view for PowerEdge R7725 system

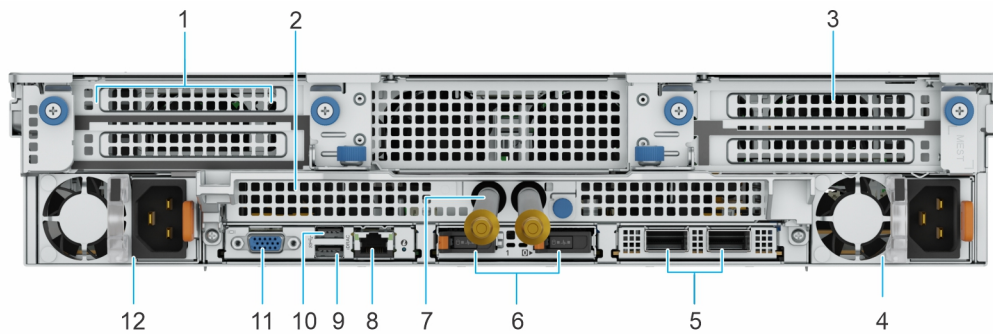







Figure 11. Rear view of the Direct Liquid Cooling (DLC) configuration

Table 11. Rear view of the system

Item	Ports, panels, or slots	Icon	Description
1	PCIe expansion card riser 2	N/A	Enables you to connect PCI Express expansion cards.
2	PCIe expansion card riser 1	N/A	Enables you to connect second OCP 3.0.
3	PCIe expansion card riser 5	N/A	Enables you to connect PCI Express expansion cards.
4	Power supply unit (PSU 2)		Indicates the PSU 2.
5	OCP NIC ports	N/A	This port supports OCP 3.0.
6	BOSS-N1 DC-MHS	N/A	Enables you to install the BOSS-N1 Datacenter Modular Hardware System (DC-MHS) module.
7	Liquid cooling module tubes	N/A	Cold coolant flows into the system from one tube and hot coolant leaves the system from another tube.
8	Dedicated BMC Ethernet port		Enables you to remotely access Open Server Manager.
9	USB 3.1 port		The USB port is 9-pin and 3.0-compliant. This port enables you to connect USB devices to the system.
10	USB 3.1 port		The USB port is 9-pin and 3.0-compliant. This port enables you to connect USB devices to the system.
11	VGA port		Enables you to connect a display device to the system.
12	Power supply unit (PSU 1)		Indicates the PSU 1.

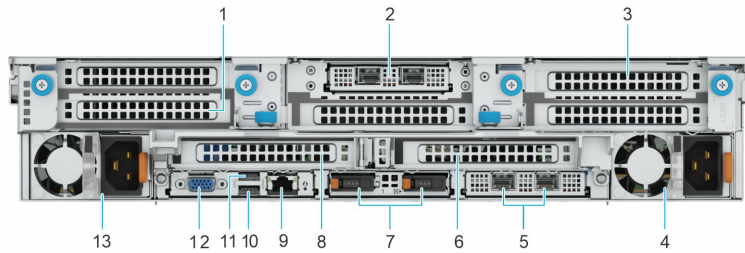







Figure 12. Rear view of the system

Table 12. Rear view of the system

Item	Ports, panels, or slots	Icon	Description
1	PCIe expansion card riser 1	N/A	Enables you to connect PCI Express expansion cards.
2	PCIe expansion card riser 3	N/A	Enables you to connect second OCP 3.0.
3	PCIe expansion card riser 5	N/A	Enables you to connect PCI Express expansion cards.
4	Power supply unit (PSU 2)		Indicates the PSU 2.
5	OCP NIC ports	N/A	This port supports OCP 3.0.
6	PCIe expansion card riser 4	N/A	Enables you to connect PCI Express expansion cards.
7	BOSS-N1 DC-MHS	N/A	Enables you to install the BOSS-N1 Datacenter Modular Hardware System (DC-MHS) module.
8	PCIe expansion card riser 2	N/A	Enables you to connect PCI Express expansion cards.
9	Dedicated BMC Ethernet port		Enables you to remotely access Open Server Manager.
10	USB 3.1 port		The USB port is 9-pin and 3.0-compliant. This port enables you to connect USB devices to the system.
11	USB 3.1 port		The USB port is 9-pin and 3.0-compliant. This port enables you to connect USB devices to the system.
12	VGA port		Enables you to connect a display device to the system.
13	Power supply unit (PSU 1)		Indicates the PSU 1.

System configurations - inside view for PowerEdge R7725 system

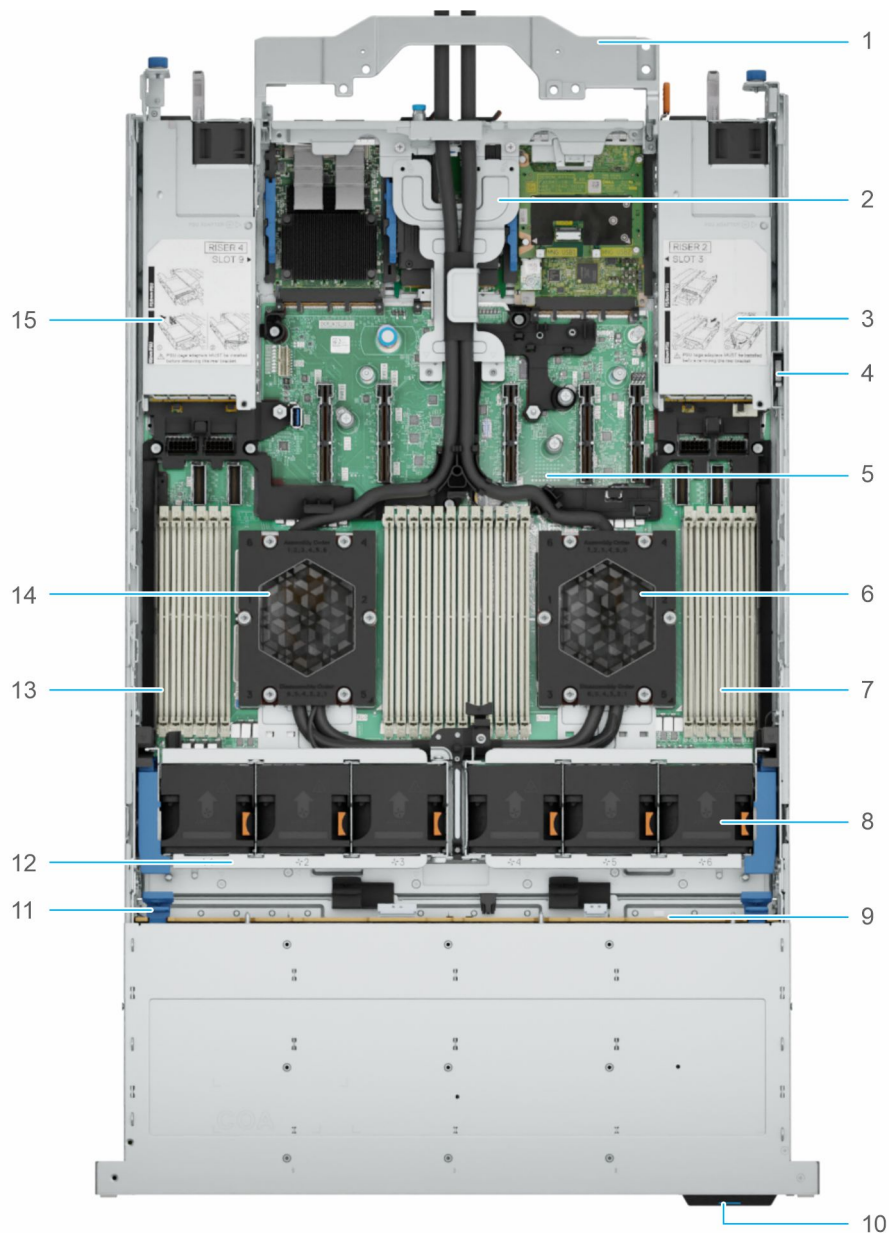

Figure 13. Inside the Direct Liquid Cooling (DLC) configuration system

1. Chassis handle
2. DLC module mid bracket
3. Riser 2
4. Intrusion Switch
5. Host Processor Module (HPM) board
6. DLC module for processor 0
7. Memory DIMM sockets for processor 0
8. Cooling fans
9. Backplane
10. Express service tag
11. Backplane release latch

- 12. Cooling fan cage
- 13. Memory DIMM sockets for processor 1
- 14. DLC module for processor 0
- 15. Riser 4

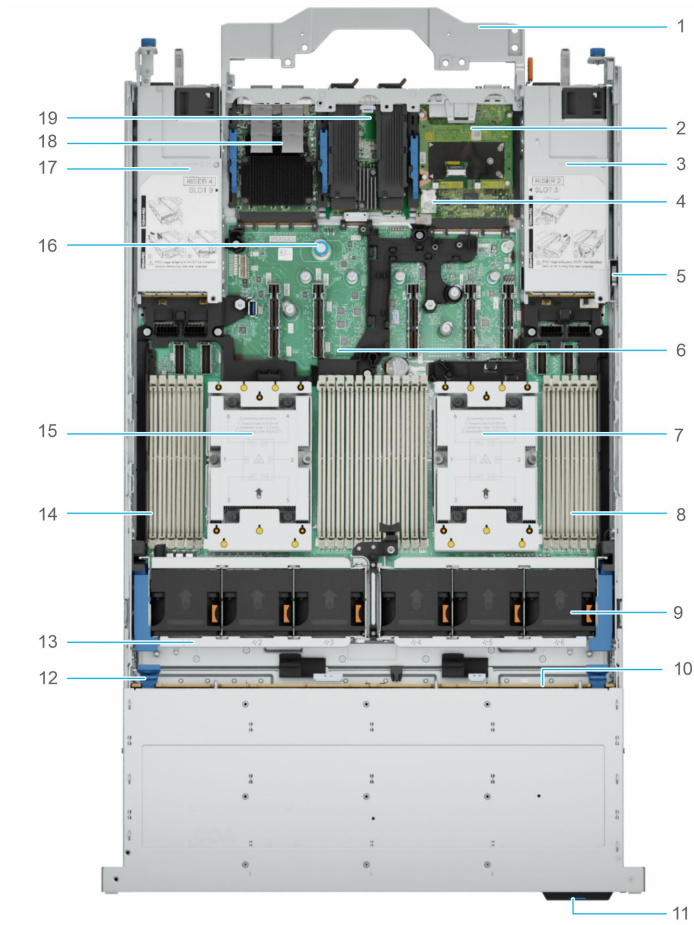

Figure 14. Inside the system

- 1. Chassis handle
- 2. Datacenter Secure Control Module (DC-SCM)
- 3. PSU 1
- 4. TPM
- 5. Intrusion Switch
- 6. Host Processor Module (HPM) board
- 7. Processor heat sink module for processor 0
- 8. Memory DIMM sockets for processor 0
- 9. Cooling fans
- 10. Backplane
- 11. Express service tag
- 12. Backplane release latch
- 13. Cooling fan cage
- 14. Memory DIMM sockets for processor 1
- 15. Processor heat sink module for processor 1
- 16. HPM handle
- 17. PSU 2
- 18. OCP 3.0 NIC card
- 19. BOSS-N1 DC-MHS module

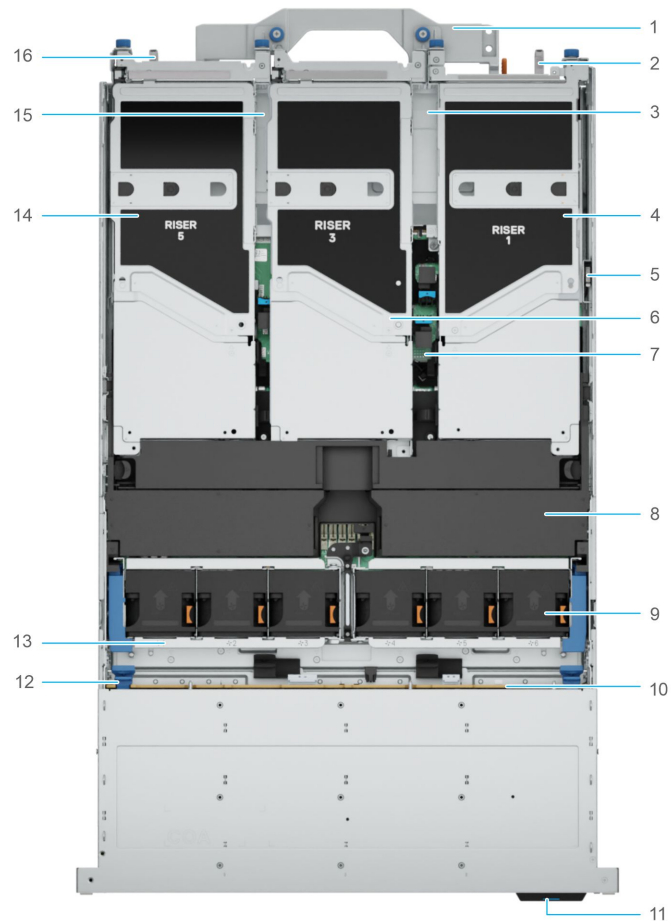

Figure 15. Inside the system with all the risers

1. Chassis handle
2. PSU 1
3. Riser 2
4. Riser 1
5. Intrusion Switch
6. Riser 3
7. Host Processor Module (HPM) board
8. Air shroud
9. Cooling fans
10. Backplane
11. Express service tag
12. Backplane release latch
13. Cooling fan cage
14. Riser 5
15. Riser 4
16. PSU 2

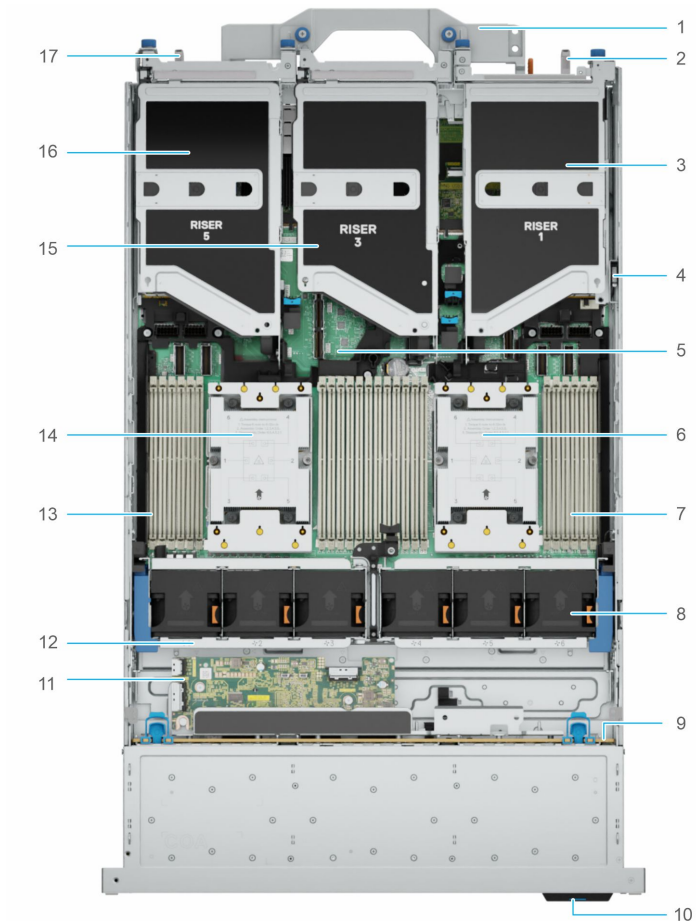

Figure 16. Inside the system with Riser 1, Riser 3 and Riser 5

1. Chassis handle
2. PSU 1
3. Riser 1
4. Intrusion Switch
5. Host Processor Module (HPM) board
6. Processor heat sink module for processor 0
7. Memory DIMM sockets for processor 0
8. Cooling fans
9. Backplane
10. Express service tag
11. Front PERC
12. Cooling fan cage
13. Memory DIMM sockets for processor 1
14. Processor heat sink module for processor 1
15. Riser 3
16. Riser 5
17. PSU 2

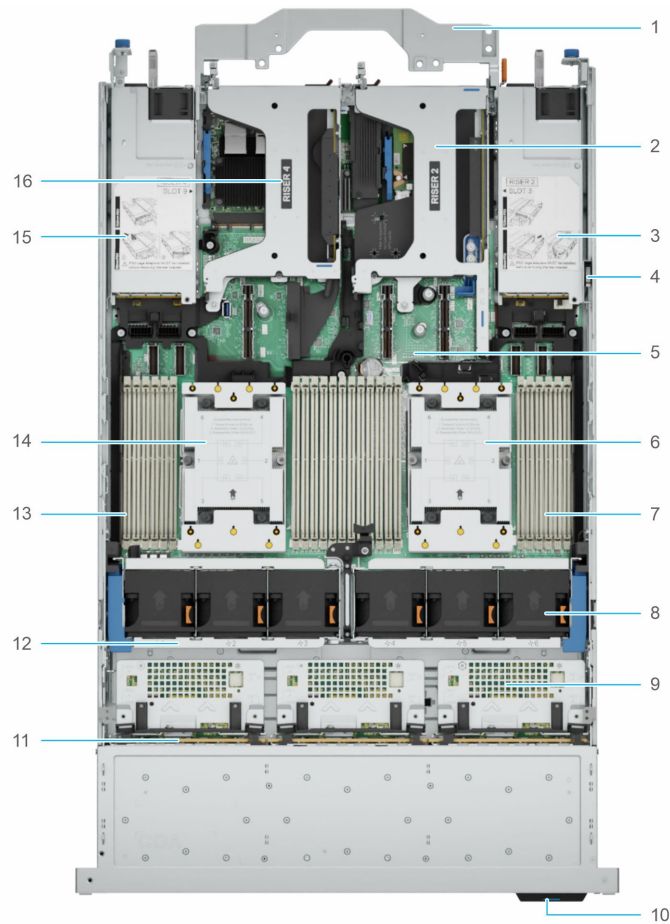

Figure 17. Inside the system with Riser 2 and Riser 4

1. Chassis handle
2. Riser 2
3. PSU 1
4. Intrusion Switch
5. Host Processor Module (HPM) board
6. Processor heat sink module for processor 0
7. Memory DIMM sockets for processor 0
8. Cooling fans
9. Front PERC
10. Express service tag
11. Backplane
12. Cooling fan cage
13. Memory DIMM sockets for processor 1
14. Processor heat sink module for processor 1
15. PSU 2
16. Riser 4

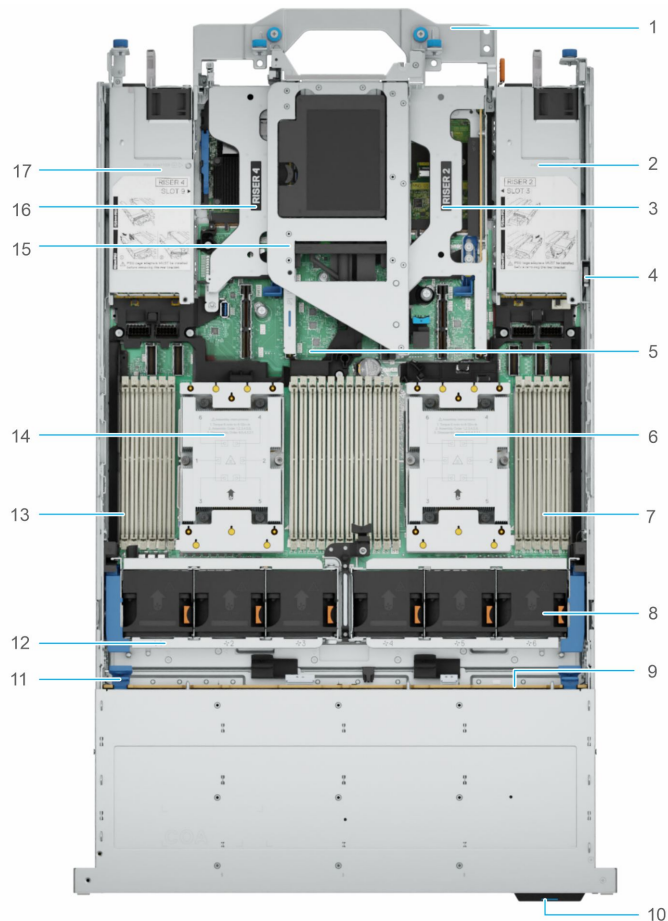

Figure 18. Inside view of the system with Riser 2, Riser 3 and Riser 4

1. Chassis handle
2. PSU 1
3. Riser 2
4. Intrusion Switch
5. Host Processor Module (HPM) board
6. Processor heat sink module for processor 0
7. Memory DIMM sockets for processor 0
8. Cooling fans
9. Backplane
10. Express service tag
11. Backplane release latch
12. Cooling fan cage
13. Memory DIMM sockets for processor 1
14. Processor heat sink module for processor 1
15. Riser 3
16. Riser 4
17. PSU 2

i **NOTE:** The system board is known as the Host Processor Module (HPM) board in this document.

Locating the Express Service Code and Service Tag

The unique Express Service Code and Service Tag are used to identify the system.

The express service tag is located on the front of the system that includes system information such as the Service Tag, Express Service Code, Manufacture date, NIC, MAC address, MyDell QR label, and so on.

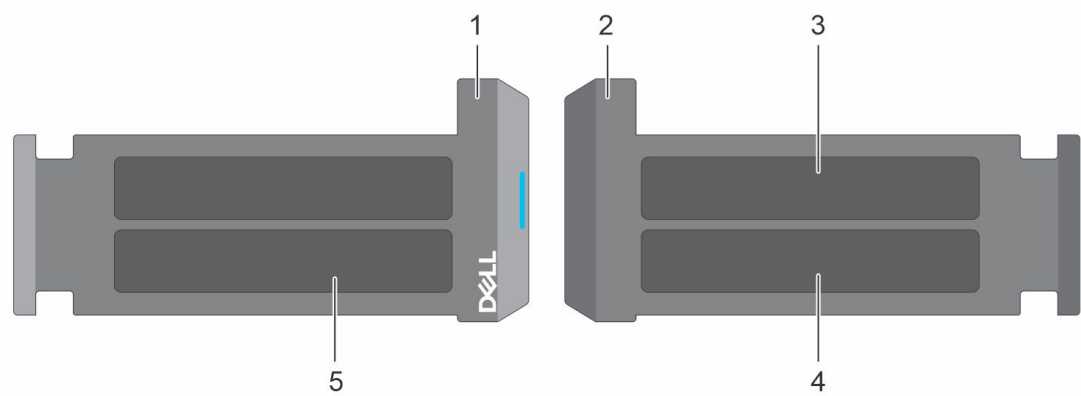

Figure 19. Locating the Express Service Code and Service tag

1. Express Service Tag (front view)
2. Express Service Tag (rear view)
3. OMM (not applicable)
4. Password and MAC address
5. Service Tag, Express Service Code, MyDell QR label

The Mini Enterprise Service Tag (MEST) label is located in the rear of the system that includes the Service Tag (ST), and Express Service Code (Exp Svc Code). The Exp Svc Code is used by Dell to route support calls to the appropriate personnel.

System information label

The system information label is on the back side of the system cover.

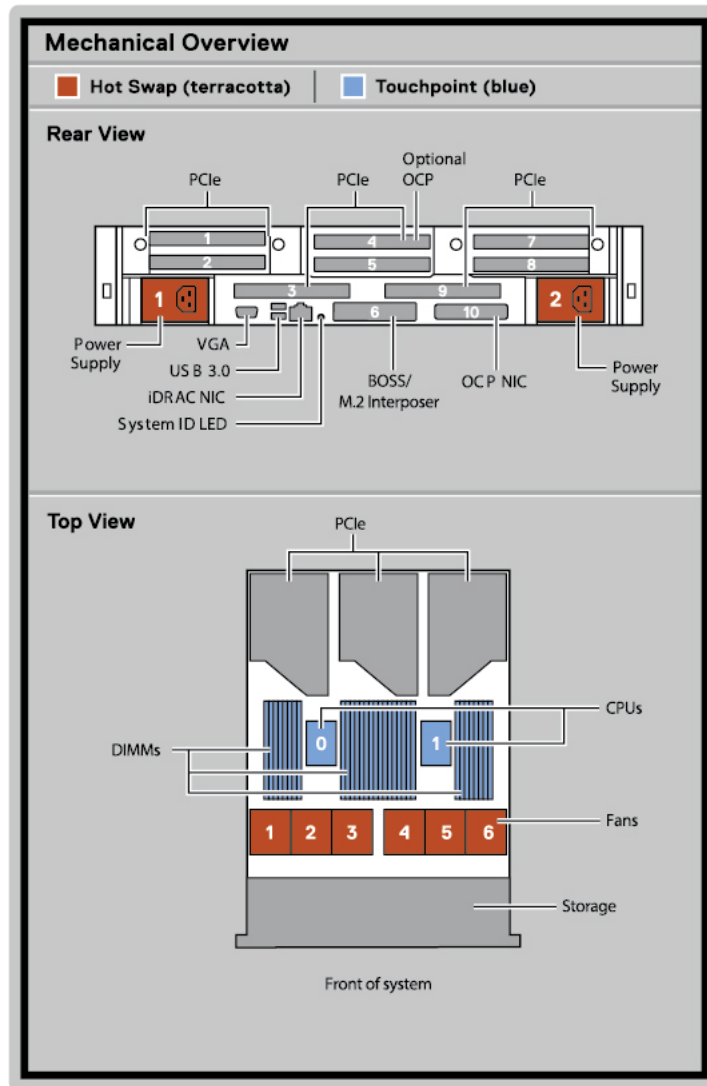

Figure 20. Mechanical overview

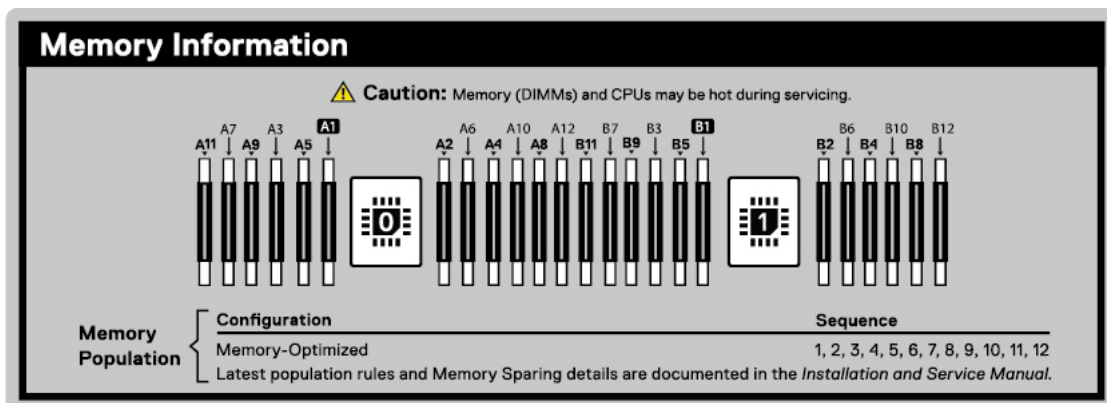

Figure 21. Memory information

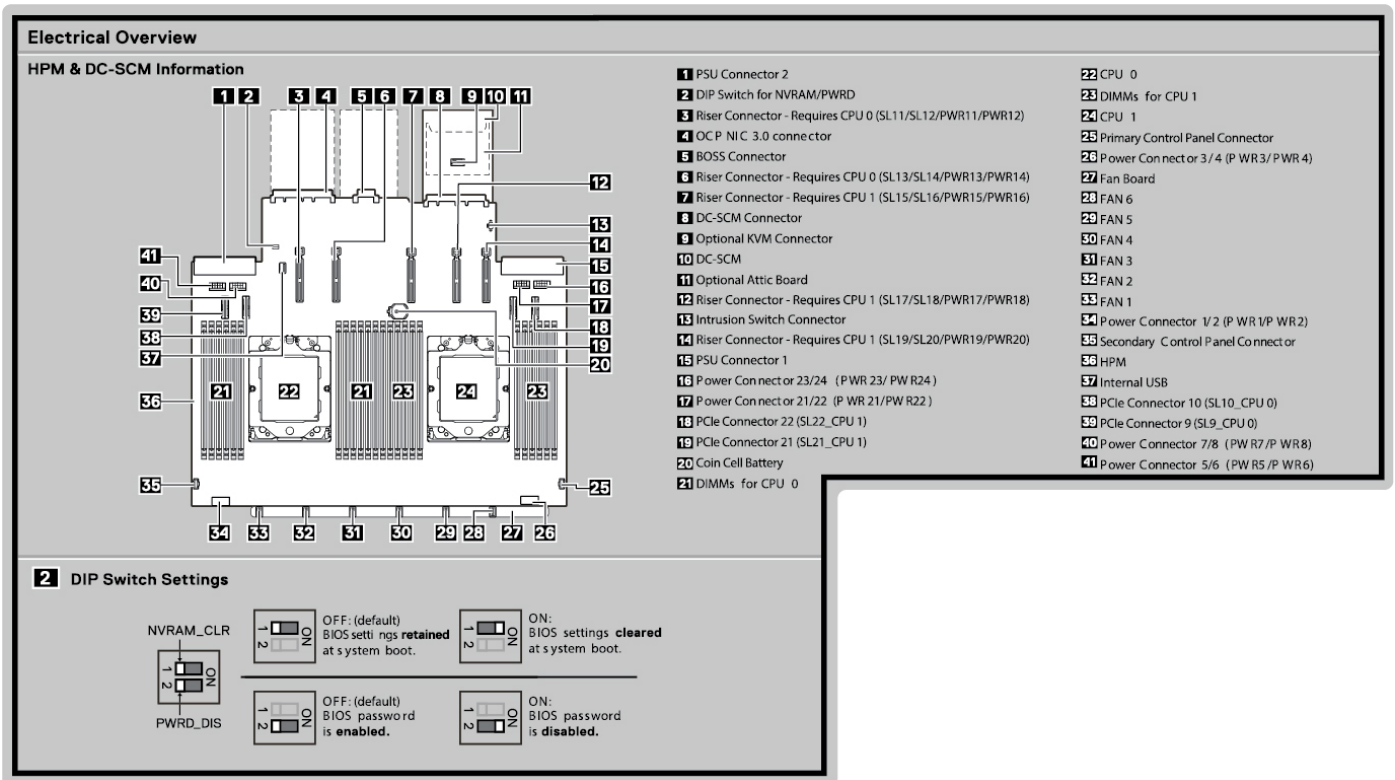

Figure 22. Electrical overview



Figure 23. Caution label

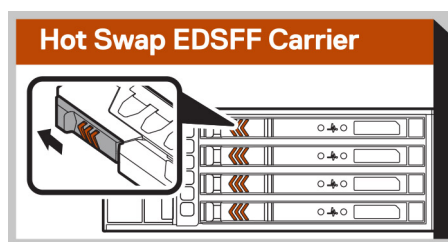

Figure 24. Hot Swap EDSFF carrier



Figure 25. Express Service Tag

Rail sizing and rack compatibility matrix

For specific information about the rail solutions compatible with your system, see the *Dell Enterprise Systems Rail Sizing and Rack Compatibility Matrix* available at [rail-rack-matrix](#).

The document provides the information that is listed below:

- Specific details about rail types and their functionalities.
- Rail adjustability range for various types of rack mounting flanges.
- Rail depth with and without cable management accessories.
- Types of racks that are supported for various types of rack mounting flanges.

Technical specifications

The technical and environmental specifications of your system are outlined in this chapter.

NOTE: This document provides a comprehensive list of product features. However, features marked with an asterisk (*) may not be available at launch but introduced in future updates. Please note that this document does not confirm the availability or release timeline of any feature. For the most accurate and up-to-date information on feature availability, please refer to the product configurator page on dell.com.

Topics:

- [Chassis dimensions](#)
- [System weight](#)
- [Processor specifications](#)
- [PSU specifications](#)
- [Cooling fan specifications](#)
- [Supported operating systems](#)
- [System battery specifications](#)
- [Expansion card riser specifications](#)
- [Memory specifications](#)
- [Storage controller specifications](#)
- [Drives](#)
- [GPU Specifications](#)
- [DPU Specifications](#)
- [Ports and connectors specifications](#)
- [Video specifications](#)
- [Environmental specifications](#)

Chassis dimensions

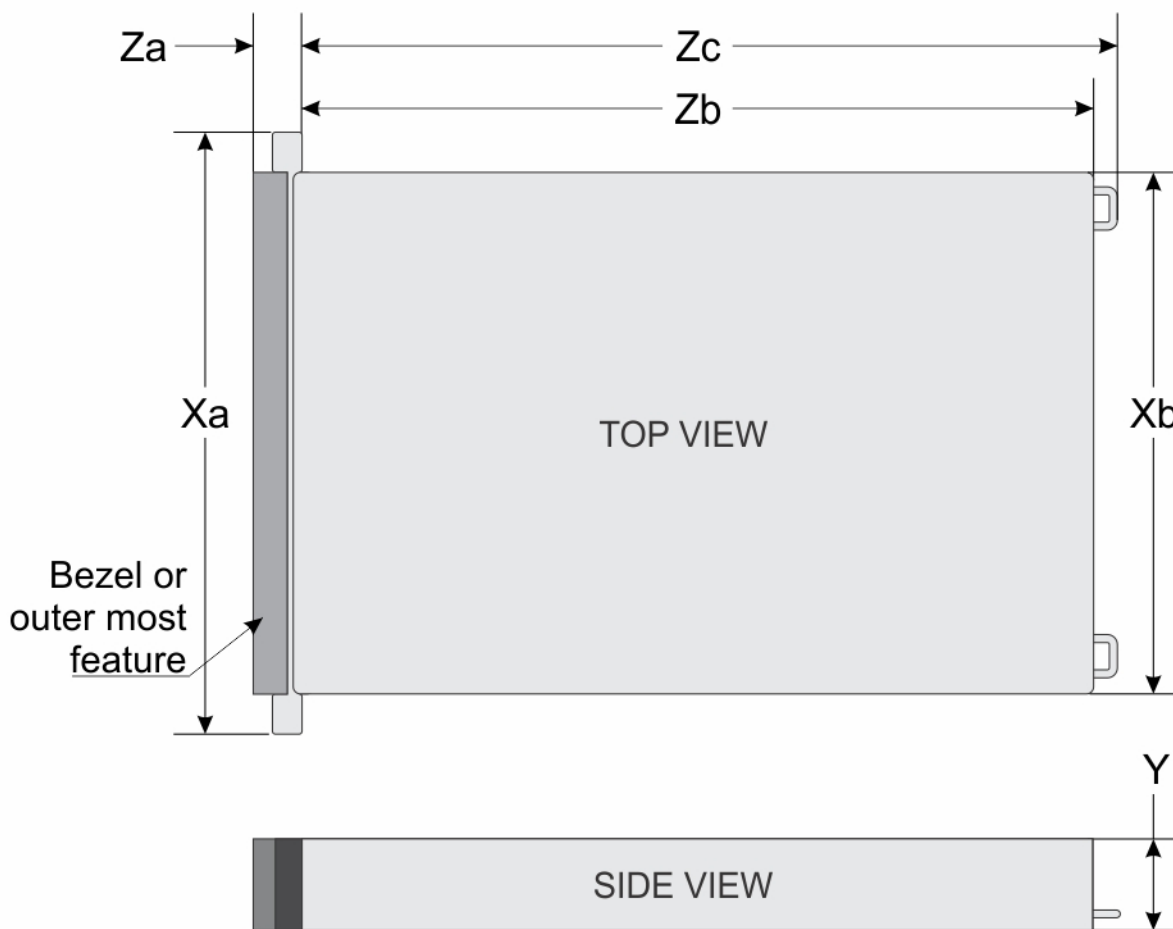

Figure 26. Chassis dimensions

Table 13. PowerEdge R7725 chassis dimensions

Drives	Xa	Xb	Y	Za	Zb	Zc
All configurations	482.0 mm (18.98 inches)	434.0 mm (17.09 inches)	86.8 mm (3.42 inches)	30.78 mm (1.21 inches) With bezel 29.89 mm (1.18 inches) Without bezel	700.7 mm (27.59 inches) Ear to rear wall	771.62 mm (30.38 inches) Ear to PSU handle

NOTE: Zb is the nominal rear wall external surface where the HPM board I/O connectors reside.

System weight

Table 14. PowerEdge R7725 system weight

System configuration	Maximum weight (with all drives/SSDs)
No backplane configuration	25.1 kg (55.34 pounds)
8 x 2.5-inch Universal	27.5 kg (60.63 pounds)

Table 14. PowerEdge R7725 system weight (continued)

System configuration	Maximum weight (with all drives/SSDs)
12 x 3.5-inch SAS/SATA	36.1 kg (69.67 pounds)
16 x 2.5-inch SAS/SATA	29.3 kg (64.59 pounds)
16 x 2.5-inch SAS/SATA + 8 x U.2 or 2.5-inch NVMe RAID	28.74 kg (63.36 pound)
24 x 2.5-inch SAS/SATA	31.8 kg (70.11 pounds)
16 x EDSFF E3.S Gen5 NVMe	25.47 kg (56.15 pound)
8 x EDSFF E3.S Gen5 NVMe	24.33 kg (53.64 pound)
32 x EDSFF E3.S Gen5 NVMe	31.14 kg (68.65 pounds)
40 x EDSFF E3.S Gen5 NVMe	29.92 kg (65.96 pounds)

Table 15. PowerEdge R7725 weight handling recommendations

Chassis weight	Description
40–70 pounds	Recommend two people to lift.
70–120 pounds	Recommend three people to lift.
≥ 121 pounds	Recommend to use a server-lift.

Processor specifications

Table 16. PowerEdge R7725 processor specifications

Supported processor	Number of processors supported
5 th Generation AMD EPYC 9005 Series processor	Two

PSU specifications

The PowerEdge R7725 system supports up to two AC or DC power supply units (PSUs).

Table 17. PSU specifications

PSU	Class	Heat dissipation (maximum) (BTU/hr)	Frequency (Hz)	Input voltage	Current (A)
3200 W AC	Titanium	12000	50/60	200-240 Vac	16
3200 W HVDC	N/A	12000	N/A	240 Vdc	14.5
3200 XLAC	Titanium	12000	50/60	277 Vac	12.9
3200 XHVDC	N/A	12000	N/A	336 Vdc	10.47
2400 W AC	Titanium	9000	50/60	100-240 Vac	16-13.2
2400 W HVDC	N/A	9000	N/A	240 Vdc	10.9
1800 W AC*	Titanium	6750	50/60	200-240 Vac	9.8-8.2
1800 W HVDC*	N/A	6750	N/A	240 Vdc	8.2
1500 W AC	Titanium	5625	50/60	100-240 Vac	12-8.2
1500 W HVDC	N/A	5625	N/A	240 Vdc	6.8
1500 W XLAC	Titanium	5625	50/60	277 Vac	6.1
1500 W XHVDC	N/A	5625	N/A	336 Vdc	4.91

Table 17. PSU specifications (continued)

PSU	Class	Heat dissipation (maximum) (BTU/hr)	Frequency (Hz)	Input voltage	Current (A)
1400 W -48V	N/A	5310	N/A	(-48)-(-60) Vdc	3.3
1100 W AC	Titanium	4100	50/60	100-240 Vac	12-6.1
1100 W HVDC	N/A	4100	N/A	240 Vdc	5.1
1100 W AC	Platinum	4100	50/60	100-240 Vac	12-6.1
1100 W HVDC	N/A	4100	N/A	240 Vdc	5.1
800 W AC	Titanium	3000	50/60	100-240 Vac	9.2-4.5
800 W HVDC	N/A	3000	N/A	240 Vdc	3.7
800 W AC	Platinum	3000	50/60	100-240 Vac	9.2-4.5
800 W HVDC	N/A	3000	N/A	240 Vdc	3.7

- NOTE:** Heat dissipation is calculated using the PSU wattage rating.
- NOTE:** When selecting or upgrading the system configuration, to ensure optimum power utilization, verify the system power consumption with the Enterprise Infrastructure Planning Tool available at [calc](#).
- NOTE:** If a system with AC 1500 W and 1100 W PSUs operates at low line 100-120 Vac, then the power rating per PSU is degraded to 1050 W.



C13

Figure 27. PSU power cords



C19

Figure 28. C19 PSU power cord



C16

Figure 29. C16 power cord

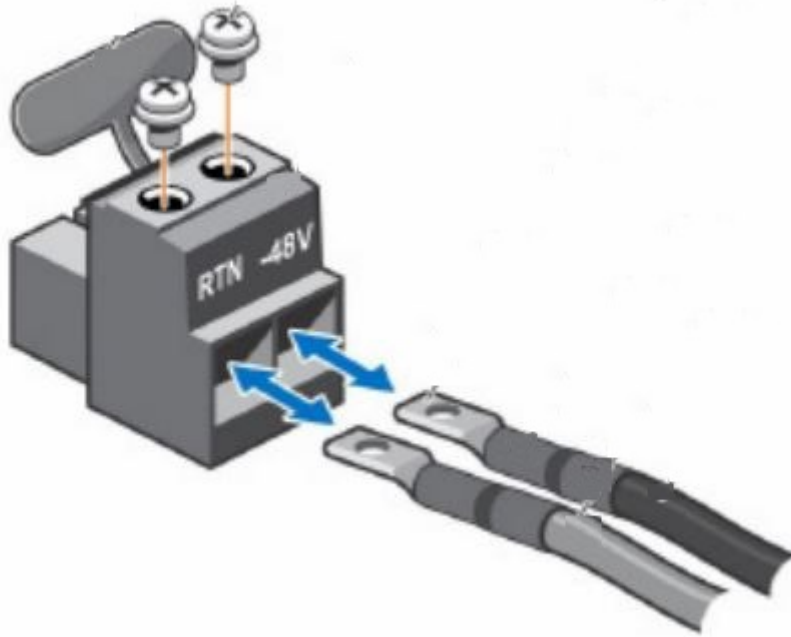

Figure 30. DC PSU power cord

Table 18. PSU power cables

Form factor	Output	Power cable
Redundant 73.5 mm	3200 W Titanium mixed mode	C19
Redundant 73.5 mm	3200 W 277 Vac and HVDC	APP/Saf-D-Grid
Redundant 60 mm	2400 W Titanium mixed mode	C19
Redundant 60 mm	1800 W Titanium mixed mode*	C16
Redundant 60 mm	1500 W Titanium mixed mode	C13
Redundant 60 mm	1500 W 277 Vac and HVDC	APP/Saf-D-Grid
Redundant 60 mm	1400 W -48 V	DC power cable
Redundant 60 mm	1100 W Titanium mixed mode	C13
Redundant 60 mm	1100 W Platinum mixed mode	C13
Redundant 60 mm	800 W Titanium mixed mode	C13
Redundant 60 mm	800 W Platinum mixed mode	C13

NOTE: This document provides a comprehensive list of product features. However, features marked with an asterisk (*) may not be available at launch but introduced in future updates. Please note that this document does not confirm the availability or release timeline of any feature. For the most accurate and up-to-date information on feature availability, please refer to the product configurator page on dell.com.

NOTE: * Feature not available at product launch in November,2025. Please refer to the product configurator page on Dell.com to confirm feature availability.

Cooling fan specifications

The PowerEdge R7725 system supports up to six cooling fans.

Table 19. Cooling fan specifications

Fan type	Abbreviation	Also known as	Label color	Label image
High Performance Silver (HPR Silver) fans	HPR SLVR	Silver	Silver	
High Performance Gold (HPR Gold) fans	HPR GOLD	Gold	Gold	
High Performance Platinum (HPR Pltm) fans	HPR PLTM	Platinum	Platinum	

NOTE: Cooling fans rotate at slower speed, even while the system is in standby mode, and the fan speed varies in response to changes in the ambient temperature.

Supported operating systems

The PowerEdge R7725 system supports the following operating systems:

- Microsoft Windows Server with Hyper-V
- Canonical Ubuntu Server LTS
- RedHat Enterprise Linux
- SUSE Linux Enterprise Server
- VMware ESXi

For specifications and interoperability details, see [OS support](#).

System battery specifications

The PowerEdge R7725 system uses one CR 2032 3.0-V lithium coin cell battery.

Expansion card riser specifications

The PowerEdge R7725 system supports up to four PCI express (PCIe) slots (Gen5 slots), dual OCP NIC, and BOSS on the HPM board.

Table 20. Expansion card slots supported on the HPM board

PCIe slot	Expansion card riser	Processor connection	Height	Length	Slot width
Slot 1	R1a	Processor 2	Full Height	Half Length	x8
Slot 2	R1a, R1b, R1b_DW	Processor 2	Full Height	Half Length	x8, x16
Slot 3	R2a, R2b	Processor 2	Full Height Low-Profile in liquid cooling configuration.	Half Length	x16
Slot 4	R2b, R3a, R3b, R3e (OCP)	Processor 2	Full Height	Half Length	x8, x16
Slot 5	R3a	Processor 2	Full Height	Half Length	x8
Slot 6	BOSS	Processor 1	N/A	N/A	x4
Slot 7	R5a, R5b, R5b_DW, R5e	Processor 1	Full Height	Half Length	x8, x16
Slot 8	R5a, R5e	Processor 1	Full Height	Half Length	x8, x16
Slot 9	R4a, R4b	Processor 1	Full Height Low-Profile in liquid cooling configuration.	Half Length	x16
Slot 10	OCP	Processor 1	N/A	N/A	x16

Memory specifications

The PowerEdge R7725 system supports the following memory specifications for optimized operation.

Table 21. Memory specifications

DIMM type	DIMM rank	DIMM capacity	Dual processor	
			Minimum system capacity	Maximum system capacity
RDIMM	Dual rank	16 GB	32 GB	384 GB
		32 GB	64 GB	768 GB
		64 GB	128 GB	1.5 TB
		96 GB	192 GB	2.3 TB
		128 GB	256 GB	3.0 TB
		256 GB	512 GB	6.14 TB

Table 22. Memory module sockets

Memory module sockets	Speed
24, 288-pin	6400 MT/s (1 DPC)

NOTE: Memory DIMM slots are not hot pluggable.

NOTE: The processor may reduce the performance of the rated DIMM speed.

Storage controller specifications

The PowerEdge R7725 system supports the following controller cards:

Table 23. Storage controller cards

Supported storage controller cards
Internal controllers <ul style="list-style-type: none"> PERC H975i PERC H965i PERC H365i H965e HBA465e
Internal Boot <ul style="list-style-type: none"> Boot Optimized Storage Subsystem (BOSS-N1 DC-MHS)
Software RAID <ul style="list-style-type: none"> N/A

NOTE: For the ESXi operating system, H975i is supported on 9.0 or later versions.

Drives

The PowerEdge R7725 system supports:

- No backplane configuration
- Up to 8 x 2.5-inch SAS/SATA/NVMe
- Up to 12 x 3.5-inch SAS/SATA
- Up to 16 x 2.5-inch SAS/SATA
- Up to 24 x 2.5-inch SAS/SATA
- Up to 16 x 2.5-inch SAS/SATA + 8 x U.2 or 2.5-inch NVMe
- Up to 8 x EDSFF E3.S Gen5 NVMe

- Up to 16 x EDSFF E3.S Gen5 NVMe
- Up to 32 x EDSFF E3.S Gen5 NVMe
- Up to 40 x EDSFF E3.S Gen5 NVMe

NOTE: For more information about how to hot swap NVMe PCIe SSD device, see the *Dell Express Flash NVMe PCIe SSD User's Guide* at [Dell Support](#) page > **Browse all products > Infrastructure > Data Center Infrastructure > Storage Adapters & Controllers > Dell PowerEdge Express Flash NVMe PCIe SSD > Select This Product > Documentation > Manuals and Documents.**

GPU Specifications

The PowerEdge R7725 system supports

- Up to two 450 W double-width GPUs
- Up to six single-width GPUs

DPU Specifications

The PowerEdge R7725 platform accommodates Data Processing Units (DPUs). These units are system-on-chip solutions that combine ARM cores, high-performance NICs, and programmable acceleration engines to offload and accelerate data center infrastructure services.

Table 24. Supported Data Processing Units(DPU) Cards

Feature	NVIDIA BlueField-3 2x200 GbE B3220	NVIDIA BlueField-3 1x400 GbE B3140H *
Type	Data Processing Units (DPU)	Data Processing Units (DPU)
Networking	2 x 200 GbE	1x400 GbE
Form Factor	FHHL	FHHL
Interface	PCIe Gen5 x16	PCIe Gen5 x16
Power Consumption	150 W	75 W
Compatible Risers	RC 2(Slots2,7), RC 3(Slots2,7), RC 4(Slots 2,7), RC 5(Slots2,7), RC 8(Slots2,7)	TBD

NOTE: This document provides a comprehensive list of product features. However, features marked with an asterisk (*) may not be available at launch but introduced in future updates. Please note that this document does not confirm the availability or release timeline of any feature. For the most accurate and up-to-date information on feature availability, please refer to the product configurator page on dell.com.

NOTE: * Feature not available at product launch in November,2025. Please refer to the product configurator page on Dell.com to confirm feature availability.

Ports and connectors specifications

NIC port specifications

The PowerEdge R7725 system supports one 10/100/1000 Mbps BMC Ethernet, up to eight PCIe Add-in cards, up to two fiber channel HBA cards, and two optional Open Compute Project (OCP) cards.

Table 25. NIC port specification for the system

Feature	Specifications
Datacenter-Secure Control Module (DC-SCM)	1 GbE x 2

Table 25. NIC port specification for the system (continued)

Feature	Specifications
OCP NIC 3.0 card	200 GbE x 2 (configurable as 400 GbE x 1), 100 GbE x 2, 25 GbE x 2, 25 GbE x 4, 10 GbE x 2, 1 GbE x 4, 10 GbE x 4
PCIe Add-in Card (AIC) NIC	200 GbE x 2 (configurable as 400 GbE x 1), 100 GbE x 2, 25 GbE x 2
Fiber channel HBA	FC64, FC32

USB ports specifications

Table 26. PowerEdge R7725 USB specifications

Front		Rear		Internal (Optional)	
USB port type	No. of ports	USB port type	No. of ports	USB port type	No. of ports
USB 2.0-compliant port (optional)	One	USB 3.1-compliant port	Two	Internal USB 3.1-compliant port	One
USB type C dual-mode host/BMC Direct port	One				

VGA ports specifications

The PowerEdge R7725 system supports DB-15 DB-15 port on the rear I/O board of the Datacenter Secure Control Module (DC-SCM).

Video specifications

Table 27. Supported video resolution options

Resolution	Refresh Rate	Color depth (bits)
1024 x 768	60	8, 16, 32
1280 x 800	60	8, 16, 32
1280 x 1024	60	8, 16, 32
1360 x 768	60	8, 16, 32
1440 x 900	60	8, 16, 32
1600 x 900	60	8, 16, 32
1600 x 1200	60	8, 16, 32
1680 x 1050	60	8, 16, 32
1920 x 1080	60	8, 16, 32
1920 x 1200	60	8, 16, 32

Environmental specifications

NOTE: For additional information about environmental certifications, refer to the Product Environmental Datasheet located with the **Manuals & Documents** on [Dell Support](#).

Table 28. Continuous Operation Specifications for ASHRAE A2

Parameters	Allowable continuous operations
Temperature range for altitudes <= 900 m (<= 2953 ft)	10–35°C (50–95°F) with no direct sunlight on the equipment
Humidity percent range (non-condensing at all times)	8% RH with -12°C minimum dew point to 80% RH with 21°C (69.8°F) maximum dew point
Operational altitude de-rating	Maximum temperature is reduced by 1°C/300 m (1.8°F/984 Ft) above 900 m (2953 Ft)

Table 29. Continuous Operation Specifications for ASHRAE A3

Parameters	Allowable continuous operations
Temperature range for altitudes <= 900 m (<= 2953 ft)	5–40°C (41–104°F) with no direct sunlight on the equipment
Humidity percent range (non-condensing at all times)	8% RH with -12°C minimum dew point to 85% RH with 24°C (75.2°F) maximum dew point
Operational altitude de-rating	Maximum temperature is reduced by 1°C/175 m (1.8°F/574 Ft) above 900 m (2953 Ft)

Table 30. Continuous Operation Specifications for ASHRAE A4

Parameters	Allowable continuous operations
Temperature range for altitudes <= 900 m (<= 2953 ft)	5–45°C (41–113°F) with no direct sunlight on the equipment
Humidity percent range (non-condensing at all times)	8% RH with -12°C minimum dew point to 90% RH with 24°C (75.2°F) maximum dew point
Operational altitude de-rating	Maximum temperature is reduced by 1°C/125 m (1.8°F/410 Ft) above 900 m (2953 Ft)

Table 31. Common Environmental Specifications for ASHRAE A2, A3, and A4

Parameters	Allowable continuous operations
Maximum temperature gradient (applies to both operation and non-operation)	20°C in an hour* (36°F in an hour) and 5°C in 15 minutes (9°F in 15 minutes), 5°C in an hour* (9°F in an hour) for tape <i>i</i> NOTE: * - Per ASHRAE thermal guidelines for tape hardware, these are not instantaneous rates of temperature change.
Non-operational temperature limits	<ul style="list-style-type: none"> -40°C to 65°C (-40°F to 149°F) applicable for air cooling configuration -40°C to -5°C (-40°F to 23°F**) applicable for DLC configuration <i>i</i> NOTE: ** Liquid filled components, or systems/solutions containing liquid filled components are limited to approximately 5°C above their freeze point. At this time the only authorized liquid coolant is Recochem PG25 with a freeze point between -9°C and -13°C, therefore the lower non-operational temperature limit is -5°C. Components and systems/solutions that can contain liquid but do not at the time of testing shall be tested to the -40°C lower non-operational temperature limit.
Non-operational humidity limits	5% to 95% RH with 27°C (80.6°F) maximum dew point
Maximum non-operational altitude	12,000 meters (39,370 ft)
Maximum operational altitude	3,048 meters (10,000 ft)

Table 32. Maximum vibration specifications

Maximum vibration	Specifications
Operating	0.21 G _{rms} at 5 Hz to 500 Hz for 10 min (all x, y, and z axes)

Table 32. Maximum vibration specifications (continued)

Maximum vibration	Specifications
Storage	1.38 G _{rms} at 7 Hz to 250 Hz for 15 minutes (all six sides tested)

Table 33. Maximum shock pulse specifications

Maximum shock pulse	Specifications
Operating	Six consecutively performed shock pulses in the positive and negative x, y, and z axis of 6 G for up to 11 ms.
Storage	Six consecutively performed shock pulses in the positive and negative x, y, and z axis (one pulse on each side of the system) of 71 G for up to 2 ms.

Particulate and gaseous contamination specifications

The following table defines the limitations that help avoid any equipment damage or failure from particulates and gaseous contamination. If the levels of particulates or gaseous pollution exceed the specified limitations and result in equipment damage or failure, you must rectify the environmental conditions. Remediation of environmental conditions is the responsibility of the customer.

Table 34. Particulate contamination specifications

Particulate contamination	Specifications
Air filtration: Conventional Data Center only	<p>Data center air filtration as defined by ISO Class 8 per ISO 14644-1 with a 95% upper confidence limit</p> <p>i NOTE: Filtering room air with a MERV8 filter, as specified in ANSI/ASHRAE Standard 127, is a recommended method for achieving the necessary environmental conditions.</p> <p>i NOTE: Air entering the data center must have MERV11 or MERV13 filtration.</p> <p>i NOTE: This condition applies to data center environments only. Air filtration requirements do not apply to IT equipment designed to be used outside a data center, in environments such as an office or factory floor.</p>
Walk-Up Edge Data Center or Cabinet (sealed, closed loop environment)	<p>Filtration is not required for cabinets that are anticipated to be opened six times or less per year. Class 8 per ISO 1466-1 filtration as defined above is required otherwise.</p> <p>i NOTE: In environments commonly above ISA-71 Class G1 or that may have known challenges, special filters may be required.</p>
Conductive dust: data center and non-data center environments	<p>Air must be free of conductive dust, zinc whiskers, or other conductive particles.</p> <p>i NOTE: Conductive dust, which can interfere with equipment operation, can originate from various sources, including manufacturing processes and zinc whiskers that may develop on the plating of raised floor tiles.</p> <p>i NOTE: This condition applies to data center and non-data center environments.</p>
Corrosive dust: data center and non-data center environments	<ul style="list-style-type: none"> • Air must be free of corrosive dust. • Residual dust present in the air must have a deliquescent point less than 60% relative humidity. <p>i NOTE: This condition applies to data center and non-data center environments.</p>

Table 35. Gaseous contamination specifications

Gaseous contamination	Specifications	Notes
Copper coupon corrosion rate	ISA-71 Class G1: <300 Å/month	Per ANSI/ISA71.04
Silver coupon corrosion rate	ISA-71 Class G1: <200 Å/month	Per ANSI/ISA71.04

Thermal restriction matrix

Table 36. Label reference

Label	Description
STD	Standard
HPR (Silver)	High performance Silver (HPR SLVR) fan
HPR (Gold)	High performance Gold (HPR GOLD) fan
HSK	Heat sink
LP	Low profile
FH	Full height
DLC	Direct Liquid Cooling

Table 37. Processor and heat sink matrix

Heat sink	Processor TDP
STD HSK	< 180 W
2U HPR HSK	>= 180 W
T-wing HSK	Supports all TDP (system should be installed with GPU/FGPA/long PCIe cards)

NOTE: The configuration's ambient temperature is dictated by its critical component. For example, if the processor's ambient temperature is 35°C, the DIMM is 35°C, and the GPU is 30°C, the configuration's ambient temperature can only be 30°C.

Table 38. CPU thermal restriction matrix for air cooling configuration

Configuration						16x2.5"SAS +8xNVMe	16xE 3.S	8xE3.S	32xE 3.S	16x2.5"SAS	8x2. 5" Univ ersal	No BP				
Shroud						CPU ≤400 W regul ar shrou d, CPU 500 W T- wing shrou d	DW GPU shrou d	CPU ≤400 W regul ar shrou d, CPU 500 W T- wing shrou d	CPU ≤400 W regul ar shrou d, CPU 500 W T- wing shrou d	CPU ≤400 W regul ar shrou d, CPU 500 W T- wing shrou d	DW GPU shrou d	CPU ≤400 W regul ar shrou d, CPU 500 W T- wing shrou d	CPU ≤400 W regul ar shrou d, CPU 500 W T- wing shrou d	DW GPU shrou d		
DW GPU (riser config RC4)						No	Yes	No	No	Yes	No	No	Yes	No	No	Yes
PPCM config						C05- 01, 02, 03	C05- 02, 03	C07- 01	C06-01	C08- 01	C02-01, 02	C04- 02	C0			
GPU grou p	TDP (W)	cTDP (W)	Mod el	Core coun t	Produ ctio n OPN											
C	125	120-1 55	9015	8	100-0 0000 1553	Stand ard HSK HPR Slvr Fan	1U T- type HSK HPR Pltm Fan	Stand ard HSK HPR Gold Fan	Stand ard HSK HPR Gold Fan	1U T- type HSK HPR Pltm Fan	Stand ard HSK HPR Gold Fan	Stand ard HSK HPR Slvr Fan	1U T- type HSK HPR Pltm Fan	Stand ard HSK HPR Slvr Fan	Stand ard HSK HPR Slvr Fan	1U T- type HSK HPR Pltm Fan
	125	120-1 55	9115	16	100-0 0000 1552	Stand ard HSK HPR Slvr Fan	1U T- type HSK HPR Pltm Fan	Stand ard HSK HPR Gold Fan	Stand ard HSK HPR Gold Fan	1U T- type HSK HPR Pltm Fan	Stand ard HSK HPR Gold Fan	Stand ard HSK HPR Slvr Fan	1U T- type HSK HPR Pltm Fan	Stand ard HSK HPR Slvr Fan	Stand ard HSK HPR Slvr Fan	1U T- type HSK HPR Pltm Fan
B	210	200- 240	9335	32	100-0 0000 1149	Stand ard HSK HPR Slvr Fan	1U T- type HSK HPR Pltm Fan	Stand ard HSK HPR Gold Fan	Stand ard HSK HPR Gold Fan	1U T- type HSK HPR Pltm Fan	Stand ard HSK HPR Gold Fan	Stand ard HSK HPR Slvr Fan	1U T- type HSK HPR Pltm Fan	Stand ard HSK HPR Slvr Fan	Stand ard HSK HPR Slvr Fan	1U T- type HSK HPR Pltm Fan
	200	200- 240	9255	24	100-0 0000 0694	Stand ard HSK HPR Slvr Fan	1U T- type HSK HPR Pltm Fan	Stand ard HSK HPR Gold Fan	Stand ard HSK HPR Gold Fan	1U T- type HSK HPR Pltm Fan	Stand ard HSK HPR Gold Fan	Stand ard HSK HPR Slvr Fan	1U T- type HSK HPR Pltm Fan	Stand ard HSK HPR Slvr Fan	Stand ard HSK HPR Slvr Fan	1U T- type HSK HPR Pltm Fan
	200	200- 240	9135	16	100-0 0000 1150	Stand ard HSK HPR Slvr Fan	1U T- type HSK HPR Pltm Fan	Stand ard HSK HPR Gold Fan	Stand ard HSK HPR Gold Fan	1U T- type HSK HPR Pltm Fan	Stand ard HSK HPR Gold Fan	Stand ard HSK HPR Slvr Fan	1U T- type HSK HPR Pltm Fan	Stand ard HSK HPR Slvr Fan	Stand ard HSK HPR Slvr Fan	1U T- type HSK HPR Pltm Fan

Table 38. CPU thermal restriction matrix for air cooling configuration (continued)

Configuration						16x2.5"SAS +8xNVMe	16xE 3.S	8xE3.S	32xE 3.S	16x2.5"SAS	8x2.5" Universal	No BP				
Shroud						CPU ≤400 W regular shroud, CPU 500 W T-wing shroud	DW GPU shroud	CPU ≤400 W regular shroud, CPU 500 W T-wing shroud	CPU ≤400 W regular shroud, CPU 500 W T-wing shroud	DW GPU shroud	CPU ≤400 W regular shroud, CPU 500 W T-wing shroud	CPU ≤400 W regular shroud, CPU 500 W T-wing shroud	CPU ≤400 W regular shroud, CPU 500 W T-wing shroud	DW GPU shroud		
DW GPU (riser config RC4)						No	Yes	No	No	Yes	No	No	Yes	No	No	Yes
PPCM config						C05-01, 02, 03	C05-02, 03	C07-01	C06-01	C08-01	C02-01, 02	C04-02	C0			
GPU group	TDP (W)	cTDP (W)	Model	Core count	Production OPN											
A	280	240-300	9355	32	100-00001148	Standard HSK HPR Slvr Fan	1U T-type HSK HPR Pltm Fan	Standard HSK HPR Gold Fan	Standard HSK HPR Gold Fan	1U T-type HSK HPR Pltm Fan	Standard HSK HPR Slvr Fan	Standard HSK HPR Pltm Fan	Standard HSK HPR Slvr Fan	Standard HSK HPR Slvr Fan	1U T-type HSK HPR Pltm Fan	
E	320	320-400	9175 F	16	100-00001145	Standard HSK HPR Gold Fan	**1U T-type HSK HPR Pltm Fan	Standard HSK HPR Gold Fan	Standard HSK HPR Gold Fan	1U T-type HSK HPR Pltm Fan	Standard HSK HPR Slvr Fan	Standard HSK HPR Pltm Fan	Standard HSK HPR Slvr Fan	Standard HSK HPR Slvr Fan	1U T-type HSK HPR Pltm Fan	
	320	320-400	9275 F	24	100-00001144	Standard HSK HPR Gold Fan	DLC only	Standard HSK HPR Gold Fan	Standard HSK HPR Gold Fan	**1U T-type HSK HPR Pltm Fan	Standard HSK HPR Slvr Fan	Standard HSK HPR Slvr Fan	Standard HSK HPR Slvr Fan	Standard HSK HPR Slvr Fan	**1U T-type HSK HPR Pltm Fan	
	320	320-400	9375 F	32	100-00001197	Standard HSK HPR Gold Fan	**1U T-type HSK HPR Pltm Fan	Standard HSK HPR Gold Fan	Standard HSK HPR Gold Fan	1U T-type HSK HPR Pltm Fan	Standard HSK HPR Slvr Fan	Standard HSK HPR Pltm Fan	Standard HSK HPR Slvr Fan	Standard HSK HPR Slvr Fan	1U T-type HSK HPR Pltm Fan	
	360	320-400	9475 F	48	100-00001143	Standard HSK	**1U T-type HSK	Standard HSK	Standard HSK	1U T-type HSK	Standard HSK	Standard HSK	**1U T-type HSK	Standard HSK	Standard HSK	1U T-type HSK

Table 38. CPU thermal restriction matrix for air cooling configuration (continued)

Configuration						16x2.5"SAS +8xNVMe	16xE 3.S	8xE3.S	32xE 3.S	16x2.5"SAS	8x2. 5" Univ ersal	No BP				
Shroud						CPU ≤400 W regul ar shrou d, CPU 500 W T- wing shrou d	DW GPU shrou d	CPU ≤400 W regul ar shrou d, CPU 500 W T- wing shrou d	CPU ≤400 W regul ar shrou d, CPU 500 W T- wing shrou d	DW GPU shrou d	CPU ≤400 W regul ar shrou d, CPU 500 W T- wing shrou d	CPU ≤400 W regul ar shrou d, CPU 500 W T- wing shrou d	CPU ≤400 W regul ar shrou d, CPU 500 W T- wing shrou d	DW GPU shrou d		
DW GPU (riser config RC4)						No	Yes	No	No	Yes	No	No	Yes	No	No	Yes
PPCM config						C05- 01, 02, 03	C05- 02, 03	C07- 01	C06-01	C08- 01	C02-01, 02	C04- 02	C0			
GPU grou p	TDP (W)	cTDP (W)	Mod el	Core coun t	Prod uctio n OPN											
						HPR Gold Fan	HPR Pltm Fan	HPR Gold Fan	HPR Gold Fan	HPR Pltm Fan	HPR Gold Fan	HPR Slvr Fan	HPR Pltm Fan	HPR Slvr Fan	HPR Slvr Fan	HPR Pltm Fan
	360	320- 400	9555	64	100-0 0000 1142	Stand ard HSK HPR Gold Fan	**1U T- type HSK HPR Pltm Fan	Stand ard HSK HPR Gold Fan	Stand ard HSK HPR Gold Fan	1U T- type HSK HPR Pltm Fan	Stand ard HSK HPR Gold Fan	Stand ard HSK HPR Slvr Fan	**1U T- type HSK HPR Pltm Fan	Stand ard HSK HPR Slvr Fan	Stand ard HSK HPR Slvr Fan	1U T- type HSK HPR Pltm Fan
	320	320- 400	9575 F	64	100-0 0000 1554	Stand ard HSK HPR Gold Fan	**1U T- type HSK HPR Pltm Fan	Stand ard HSK HPR Gold Fan	Stand ard HSK HPR Gold Fan	1U T- type HSK HPR Pltm Fan	Stand ard HSK HPR Gold Fan	Stand ard HSK HPR Slvr Fan	**1U T- type HSK HPR Pltm Fan	Stand ard HSK HPR Slvr Fan	Stand ard HSK HPR Slvr Fan	1U T- type HSK HPR Pltm Fan
	400	320- 400	9655	96	100-0 0000 0674	Stand ard HSK HPR Gold Fan	**1U T- type HSK HPR Pltm Fan	Stand ard HSK HPR Gold Fan	Stand ard HSK HPR Gold Fan	1U T- type HSK HPR Pltm Fan	Stand ard HSK HPR Gold Fan	Stand ard HSK HPR Slvr Fan	**1U T- type HSK HPR Pltm Fan	Stand ard HSK HPR Slvr Fan	Stand ard HSK HPR Slvr Fan	1U T- type HSK HPR Pltm Fan
	400	320- 400	9745	128	100-0 0000 1460	Stand ard HSK HPR Gold Fan	**1U T- type HSK HPR Pltm Fan	Stand ard HSK HPR Gold Fan	Stand ard HSK HPR Gold Fan	1U T- type HSK HPR Pltm Fan	Stand ard HSK HPR Gold Fan	Stand ard HSK HPR Slvr Fan	**1U T- type HSK HPR Pltm Fan	Stand ard HSK HPR Slvr Fan	Stand ard HSK HPR Slvr Fan	1U T- type HSK HPR Pltm Fan

Table 38. CPU thermal restriction matrix for air cooling configuration (continued)

Configuration						16x2.5"SAS+8xNVMe	16xE3.S	8xE3.S	32xE3.S	16x2.5"SAS	8x2.5" Universal	No BP				
Shroud						CPU ≤400 W regular shroud, CPU 500 W T-wing shroud	DW GPU shroud	CPU ≤400 W regular shroud, CPU 500 W T-wing shroud	CPU ≤400 W regular shroud, CPU 500 W T-wing shroud	DW GPU shroud	CPU ≤400 W regular shroud, CPU 500 W T-wing shroud	CPU ≤400 W regular shroud, CPU 500 W T-wing shroud	CPU ≤400 W regular shroud, CPU 500 W T-wing shroud	CPU ≤400 W regular shroud, CPU 500 W T-wing shroud	DW GPU shroud	
DW GPU (riser config RC4)						No	Yes	No	No	Yes	No	No	Yes	No	No	Yes
PPCM config						C05-01, 02, 03	C05-02, 03	C07-01	C06-01	C08-01	C02-01, 02	C04-02	C0			
GPU group	TDP (W)	cTDP (W)	Model	Core count	Production OPN											
	390	320-400	9825	144	100-00000837	Standard HSK HPR Gold Fan	**1U T-type HSK HPR Pltm Fan	Standard HSK HPR Gold Fan	Standard HSK HPR Gold Fan	1U T-type HSK HPR Pltm Fan	Standard HSK HPR Gold Fan	Standard HSK HPR Slvr Fan	**1U T-type HSK HPR Pltm Fan	Standard HSK HPR Slvr Fan	Standard HSK HPR Slvr Fan	1U T-type HSK HPR Pltm Fan
	390	320-400	9845	160	100-00001458	Standard HSK HPR Gold Fan	**1U T-type HSK HPR Pltm Fan	Standard HSK HPR Gold Fan	Standard HSK HPR Gold Fan	1U T-type HSK HPR Pltm Fan	Standard HSK HPR Gold Fan	Standard HSK HPR Slvr Fan	**1U T-type HSK HPR Pltm Fan	Standard HSK HPR Slvr Fan	Standard HSK HPR Slvr Fan	1U T-type HSK HPR Pltm Fan
G	500	450-500	9965	192	100-00000976	1U T-type HSK HPR Pltm Fan	DLC only	1U T-type HSK HPR Pltm Fan	1U T-type HSK HPR Pltm Fan	DLC only	1U T-type HSK HPR Pltm Fan	1U T-type HSK HPR Pltm Fan	DLC only	1U T-type HSK HPR Pltm Fan	1U T-type HSK HPR Pltm Fan	DLC only
	500	450-500	9755	128	100-00001443	1U T-type HSK HPR Pltm Fan	DLC only	1U T-type HSK HPR Pltm Fan	1U T-type HSK HPR Pltm Fan	DLC only	1U T-type HSK HPR Pltm Fan	1U T-type HSK HPR Pltm Fan	DLC only	1U T-type HSK HPR Pltm Fan	1U T-type HSK HPR Pltm Fan	DLC only

Table 39. Memory thermal restriction matrix for air cooling configuration

Configuration	16x2.5"SAS+8xNVMe	16xE3.S	8xE3.S	32xE3.S	16x2.5"SAS	8x2.5" Universal	No BP
16 GB RDIMM	Supported at 35°C						

Table 39. Memory thermal restriction matrix for air cooling configuration (continued)

Configuration	16x2.5"SAS+8xNVMe	16xE3.S	8xE3.S	32xE3.S	16x2.5"SAS	8x2.5"Universal	No BP		
32 GB RDIMM	Supported at 35°C								
64 GB RDIMM	Supported at 35°C								
96 GB RDIMM	Supported at 35°C								
128 GB RDIMM	HPR Gold Fan	Supported at 35°C			HPR Gold Fan	Supported at 35°C	HPR Gold Fan	HPR Gold Fan	Supported at 35°C
256 GB RDIMM	7F0CF (HPR Gold Fan)	7F0CF (HPR Gold Fan)	Supported at 35°C		7F0CF (HPR Gold Fan)	7F0CF (HPR Gold Fan)	HPR Gold Fan	HPR Gold Fan	Supported at 35°C

Table 40. GPU thermal restriction matrix for air cooling configuration

GPU	TDP (W)	16x2.5"SAS+8xNVMe	16xE3.S	8xE3.S	32xE3.S	16x2.5"SAS	8x2.5"Universal	No BP				
L4 24 GB	72	**HPR Gold fan	Supported at 35°C		HPR Gold fan	Supported at 35°C		HPR Gold fan	HPR Gold fan	Supported at 35°C		
H100 NVL 94 GB	400	TBD	Supported at 35°C	TBD	TBD	Supported at 35°C	TBD	TBD	TBD	TBD	Supported at 35°C	
NVIDIA RTX Pro 6000 BSE	450	N/A	N/A	N/A	N/A	N/A	N/A	N/A	N/A	N/A	N/A	
L40s 48 GB	350	TBD	Supported at 35°C	TBD	TBD	Supported at 35°C	TBD	TBD	Supported at 35°C	TBD	TBD	Supported at 35°C
A16 64 GB	250	TBD	Supported at 35°C	TBD	TBD	Supported at 35°C	TBD	TBD	Supported at 35°C	TBD	TBD	Supported at 35°C

NOTE: ** Components that support max 30°C.

NOTE: Components without ** support max 35°C.

NOTE: RTX Pro 6000 and H200 NVL will operate with a power cap of 450W, not 600W.

NOTE: A puck cable is required to ensure compatibility of the RTX Pro 6000 GPU with the R7725 system.

NOTE: Three fan modules are required for a single processor, and six fan modules are required for a dual processor system.

Table 41. CPU thermal restriction matrix for Direct Liquid Cooling (DLC) configuration

Configuration						16x2.5"SAS+8xNVMe	16xE3.S	8xE3.S	32xE3.S	16x2.5"SAS	8x2.5" Universal	No BP	
Shroud						CPU ≤400 W regular shroud, CPU 500 W T-wing shroud	DW GPU shroud	CPU ≤400 W regular shroud, CPU 500 W T-wing shroud	CPU ≤400 W regular shroud, CPU 500 W T-wing shroud	CPU ≤400 W regular shroud, CPU 500 W T-wing shroud	CPU ≤400 W regular shroud, CPU 500 W T-wing shroud	CPU ≤400 W regular shroud, CPU 500 W T-wing shroud	CPU ≤400 W regular shroud, CPU 500 W T-wing shroud
DW GPU (riser config RC4)						No	Yes	No	No	Yes	No	No	Yes
PPCM config						C05-01, 02, 03	C05-02, 03	C07-01	C06-01	C08-01	C02-01, 02	C04-02	C0
GPU group	TDP (W)	cTDP (W)	Model	Core count	Production OPN								
All CPU SKUs						Standard HSK HPR Slvr Fan	1U T-type HSK HPR Pltm Fan	Standard HSK HPR Gold Fan	Standard HSK HPR Gold Fan	1U T-type HSK HPR Pltm Fan	Standard HSK HPR Slvr Fan	Standard HSK HPR Slvr Fan	1U T-type HSK HPR Pltm Fan

Table 42. Memory thermal restriction matrix for Direct Liquid Cooling (DLC) configuration

Configuration	16x2.5"SAS+8xNVMe	16xE3.S	8xE3.S	32xE3.S	16x2.5"SAS	8x2.5" Universal	No BP		
16 GB RDIMM	Supported at 35°C								
32 GB RDIMM	Supported at 35°C								
64 GB RDIMM	Supported at 35°C								
96 GB RDIMM	Supported at 35°C								
128 GB RDIMM	HPR Gold Fan	Supported at 35°C			HPR Gold Fan	Supported at 35°C	HPR Gold Fan	HPR Gold Fan	Supported at 35°C
256 GB RDIMM	7FOCF (HPR Gold Fan)	7FOCF (HPR Gold Fan)	Supported at 35°C		7FOCF (HPR Gold Fan)	7FOCF (HPR Gold Fan)	HPR Gold Fan	HPR Gold Fan	Supported at 35°C

Table 43. GPU thermal restriction matrix for Direct Liquid Cooling (DLC) configuration

GPU	TDP (W)	16x2.5"SAS+8x NVMe		16xE3.S	8xE3.S		32xE3.S	16x2.5"SAS		8x2.5" Universal	No BP		
		**HPR Gold fan	Supported at 35°C		Supported at 35°C	Supported at 35°C		Supported at 35°C	**HPR Gold fan		**HPR Gold fan	Supported at 35°C	Supported at 35°C
L4 24 GB	75	**HPR Gold fan	Supported at 35°C	Supported at 35°C	Supported at 35°C	Supported at 35°C	Supported at 35°C	Supported at 35°C	Supported at 35°C	**HPR Gold fan	**HPR Gold fan	Supported at 35°C	Supported at 35°C
H100 NVL 94 GB	400	N/A	Supported at 35°C	N/A	N/A	Supported at 35°C	N/A	N/A	Supported at 35°C	N/A	N/A	N/A	Supported at 35°C
NVIDIA RTX Pro 6000 BSE	450	N/A	N/A	N/A	N/A	N/A	N/A	N/A	N/A	N/A	N/A	N/A	N/A
L40S 48 GB	350	N/A	Supported at 35°C	N/A	N/A	Supported at 35°C	N/A	N/A	Supported at 35°C	N/A	N/A	N/A	Supported at 35°C
A16 64 GB	250	N/A	Supported at 35°C	N/A	N/A	Supported at 35°C	N/A	N/A	Supported at 35°C	N/A	N/A	N/A	Supported at 35°C

NOTE: ** Components that support max 30°C.

NOTE: RTX Pro 6000 and H200 NVL will operate with a power cap of 450W, not 600W.

NOTE: A puck cable is required to ensure compatibility of the RTX Pro 6000 GPU with the R7725 system.

NOTE: Low Profile and Full Height T4 cards are installed in order to support maximum 6 pcs T4 in x 16 slots.

NOTE: All GPU/FGPA cards require 1U L-type HSK and GPU shroud.

Thermal air restrictions

Fresh air environment

- Two PSUs are required in redundant mode, however a single PSU failure is not supported.
- PCIe SSD is not supported.
- GPU and FPGA are not supported.
- CPU TDP equal or greater than 180 W are not supported.
- Rear drives are not supported.
- Non-Dell qualified peripheral cards and/or peripheral cards greater than 25 W are not supported.

Table 44. Air cooling configuration thermal restriction for AHRAE A2, A3, and A4 - No backplane configuration

ASHRAE	A2	A3/40°C (104 °F)	A4/45°C (113 °F)
CPU	T-wing HSK and HPR platinum fan are required for CPU >401 W.	CPU's > 240 W are not supported.	CPU's > 195 W are not supported.
PSU	N/A	Two PSUs are required in redundant mode. If there is a PSU failure, system performance may be reduced.	

Table 44. Air cooling configuration thermal restriction for AHSRAE A2, A3, and A4 - No backplane configuration (continued)

ASHRAE	A2	A3/40°C (104 °F)	A4/45°C (113 °F)
PCIe card	N/A	Non-Dell qualified peripheral cards and peripheral cards greater than 25 W are not supported.	
GPU/FPGA	N/A	Not supported	
DIMM	N/A	DIMMs ≥ 64 GB are not supported.	
OCP	N/A	Supported with 85 °C (185 °F) active optic cable.	OCP NICs are not supported. 85°C active optics or DAC cable is required.
BOSS	N/A	N/A	BOS-N1 is not supported.

Table 45. Air cooling configuration thermal restriction for AHSRAE A2, A3, and A4 - 8 x 2.5-inch Universal drive configuration

ASHRAE	A2	A3/40 °C (104 °F)	A4/45 °C (113 °F)
CPU	T-wing HSK and HPR platinum fan are required for CPU >401 W.	CPU > 240 W are not supported.	CPU > 195 W are not supported.
PSU	N/A	Two PSUs are required in redundant mode. If there is a PSU failure, system performance may be reduced.	
PCIe card	N/A	Non-Dell qualified peripheral cards and peripheral cards greater than 25 W are not supported.	
NVMe	N/A	Not supported	
GPU/FPGA	N/A	Not supported	
DIMM	N/A	DIMMs ≥ 64 GB are not supported.	
OCP	N/A	Supported with 85 °C (185 °F) active optic cable.	OCP NICs are not supported. 85 °C active optics or DAC cable is required.
BOSS	N/A	N/A	BOS-N1 is not supported.

Table 46. Air cooling configuration thermal restriction for AHSRAE A2, A3, and A4 - 16 x 2.5-inch Universal drive configuration

ASHRAE	A2	A3/40 °C (104 °F)	A4/45 °C (113 °F)
CPU	T-wing HSK and HPR platinum fan are required for CPU >401 W.	CPU > 240 W are not supported.	CPU > 195 W are not supported.
PSU	N/A	Two PSUs are required in redundant mode. If there is a PSU failure, system performance may be reduced.	
PCIe card	N/A	Non-Dell qualified peripheral cards and peripheral cards greater than 25 W are not supported.	
GPU/FPGA	N/A	Not supported	
DIMM	N/A	DIMMs ≥ 64 GB are not supported.	
OCP	N/A	Supported with 85 °C (185 °F) active optic cable.	OCP NICs are not supported. 85 °C active optics or DAC cable is required.
BOSS	N/A	N/A	BOS-N1 is not supported.

Table 47. Air cooling configuration thermal restriction for AHSRAE A2, A3, and A4 - 32 x EDSFF E3.S Gen5 NVMe drive configuration

ASHRAE	A2	A3/40°C (104 °F)	A4/45°C (113 °F)
CPU	T-wing HSK and HPR platinum fan are required for CPU >401 W.	Not supported	Not supported
DIMM	DIMM ≥ 96G are not supported.	Not supported	

Table 48. Liquid cooling configuration thermal restriction for AHSRAE A2, A3, and A4 - All storage configuration

ASHRAE	A2	A3/40 °C (104 °F)	A4/45 °C (113 °F)
CPU	T-wing HSK and HPR platinum fan are required for CPU >401 W.	N/A	N/A
PSU	N/A	Two PSUs are required in redundant mode. If there is a PSU failure, system performance may be reduced.	
PCIe card	N/A	Non-Dell qualified peripheral cards and peripheral cards greater than 25 W are not supported.	
GPU/FPGA	N/A	Not supported	
DIMM	N/A	DIMMs ≥ 64 GB are not supported.	
Drives	N/A	E3.S drives are not supported.	NVMe and E3.S drives are not supported.
OCP	N/A	Supported with 85 °C (185 °F) active optic cable.	OCP NICs are not supported. 85 °C active optics or DAC cable is required.
BOSS	N/A	N/A	BOS-N1 is not supported.

Other thermal restrictions

- 25 Gb and above 25 Gb PCIe/OCP cards require DAC or 85 °C active optics, M14MK (SFP28) or 4WGYD(QSFP+).
- L4 GPU: NG3PY(FH) / V9XT2(LP) slot restriction.
- C05 with RC3: Slot 3 , 9 only.

Initial system setup and configuration

This section describes the tasks for initial setup and configuration of the Dell system. The section also provides general steps to set up the system and the reference guides for detailed information.

Topics:

- [Setting up the system](#)
- [iDRAC configuration](#)
- [Install an operating system](#)

Setting up the system

Perform the following steps to set up the system:

Steps

1. Unpack the system.
2. Install the system into the rack. For more information, see the rail installation and cable management accessory guides relevant to your rail and cable management solution at [PowerEdge manuals](#).
3. Connect the peripherals to the system and the system to the electrical outlet.
4. Power on the system.

For more information about setting up the system, see the *Getting Started Guide* that is shipped with your system.

iDRAC configuration

The iDRAC is designed to make you more productive as a system administrator and improve the overall availability of servers. iDRAC alerts you to system issues, helps you to perform remote management, and reduces the need for physical access to the system.

Set up iDRAC IP address

To communicate with iDRAC, configure the network settings based on your network infrastructure. The network settings option is set to **DHCP**, by default.

For static IP configuration, request for the settings at the time of purchase.

For information about setting up an iDRAC IP address, see the links provided in the table:

Table 49. Interfaces to set up iDRAC IP address

Interface	Documentation links
iDRAC Direct	See the Integrated Dell Remote Access Controller User's Guide or for system-specific iDRAC guide, go to PowerEdge Manuals > Product Support page of your system > Documentation . To determine the most recent iDRAC release for your platform and for the latest documentation version, see KB 305325 .
OpenManage Deployment Toolkit	Dell OpenManage Deployment Toolkit User's Guide > Open Manage Deployment Toolkit.

To access iDRAC, ensure that you connect the Ethernet cable to the iDRAC dedicated network port or use the BMC Direct port by using the USB (type A) cable.

Log in to iDRAC

To log in to iDRAC, open a browser, enter the IP address and log in as an:

- iDRAC user
- Microsoft AD user
- LDAP user

For secure default access to iDRAC, the default username is `root`. Enter the iDRAC secure default password on the back of the Service Tag. For a legacy password, use `root/calvin`, the iDRAC default password is blank on the express service tag. Create a password before proceeding. You can also log in using VMware SSO or Smart Card.

Do not change the default username and password after setting up the iDRAC IP address.

For more information about logging in to the iDRAC and iDRAC licenses, see [Integrated Dell Remote Access Controller User's Guide](#).

See [KB78115](#) to determine the most recent iDRAC release for your platform and the latest documentation version.

You can also access iDRAC using RACADM. For more information, see the [Integrated Dell Remote Access Controller RACADM CLI Guide](#).

You can also access iDRAC using automation tool - Redfish API. For more information, see the [Integrated Dell Remote Access Controller User's Guide Redfish API Guide](#).

Install an operating system

You can install an operating system on a system shipped without one using the information provided.

If the system is shipped without an operating system, you can install a supported operating system by using one of the resources that are provided in the table below. For information about how to install the operating system, see the documentation links provided in the table below.

Table 50. Resources to install the operating system

Interface	Documentation links
iDRAC	See the Integrated Dell Remote Access Controller User's Guide or for system-specific iDRAC guide, go to PowerEdge Manuals > Product Support page of your system > Documentation . To determine the most recent iDRAC release for your platform and for the latest documentation version, see KB 305325 .
OpenManage Deployment Toolkit	Dell OpenManage Deployment Toolkit User's Guide > Open Manage Deployment Toolkit.
Dell certified VMware ESXi	Virtualization solutions Virtualization solutions

For more information about installation and how-to videos for operating systems that are supported on PowerEdge systems, see [Supported Operating Systems for Dell PowerEdge systems](#).

Options to download drivers and firmware

You can download drivers and firmware from the [FTP site](#). For more information about username and password, contact your TAM (Tech Account Manager).

Options to download and install OS drivers

You can choose any one of the following options to download and install OS drivers. For information about how to download or install OS drivers, see the documentation links provided in the table below.

Table 51. Options to download and install OS drivers

Option	Documentation
Dell support site	Downloading drivers and firmware section.

Table 51. Options to download and install OS drivers (continued)

Option	Documentation
iDRAC virtual media	<p data-bbox="804 271 1436 383">Integrated Dell Remote Access Controller User's Guide or for system specific, go to Integrated Dell Remote Access Controller User's Guide > Product Support page of your system > Documentation .</p> <p data-bbox="804 383 1460 481">i NOTE: To determine the most recent iDRAC release for your platform and for the latest documentation version, see TBD.</p>

Downloading drivers and firmware

It is recommended that you download and install the latest BIOS, drivers, and systems management firmware on the system.

Prerequisites

Ensure that you clear the web browser cache before downloading the drivers and firmware.

Steps

1. Go to [Drivers](#).
2. Enter the Service Tag of the system in the **Enter a Dell Service Tag, Dell Product ID or Model** field, and then press Enter.

i **NOTE:** If you do not have the Service Tag, click **Browse all products**, and navigate to your product.
3. On the displayed product page, click **Drivers & Downloads**.
On the **Drivers & Downloads** page, all drivers that are applicable to the system are displayed.
4. Download the drivers to a USB drive, CD, or DVD.

Pre-operating system management applications

You can manage basic settings and features of a system without booting to the operating system by using the system firmware.

Options to manage the pre-operating system applications

You can use any one of the following options to manage the pre-operating system applications:

- System Setup
- Boot Manager
- Preboot Execution Environment (PXE)

Topics:

- [System Setup](#)
- [Boot Manager](#)
- [PXE boot](#)

System Setup

Using the **System Setup** option, you can configure the BIOS settings, iDRAC settings, and device settings of the system.

You can access system setup by using any one of the following interfaces:

- Graphical User interface — To access go to iDRAC Dashboard, click **Configurations > BIOS Settings**.
- Text browser — To enable the text browser, use the Console Redirection.

To view

System Setup, power on the system, press F2, and click **System Setup Main Menu**.

NOTE: If the operating system begins to load before you press F2, wait for the system to finish booting, and then restart the system and try again.

The options on the

System Setup Main Menu screen are described in the following table:

Table 52. System Setup Main Menu

Option	Description
System BIOS	Enables you to configure the BIOS settings.
iDRAC Settings	Enables you to configure the iDRAC settings. The iDRAC utility is an interface to set up and configure the iDRAC parameters . You can enable or disable various iDRAC parameters by using the iDRAC utility. For more information about this utility, <i>Integrated Dell Remote Access Controller User's Guide</i> at PowerEdge Manuals .
Device Settings	Enables you to configure device settings for devices such as storage controllers or network cards.
Service Tag Settings	Enables you to configure the System Service Tag.

System BIOS

See the common options of the System BIOS here: [Support for General Solution Resources | Documentation | Dell US > Manuals and Documents > Set up BIOS on 17th Generation Dell PowerEdge Servers.](#)

Dell Open Server Manager Settings

The OSM settings is an interface to set up and configure the OSM parameters by using UEFI. You can enable or disable various OSM parameters by using the OSM settings. For more information about using OSM, see the latest Dell Open Server Manager built on OpenBMC™ User's Guide [Support for Open Server Manager | Documentation | Dell India.](#)

Device Settings

Device Settings enables you to configure device parameters such as storage controllers or network cards.

Boot Manager

The **Boot Manager** option enables you to select boot options and diagnostic utilities.

To enter **Boot Manager**, power on the system and press F11.

Table 53. Boot Manager details

Option	Description
Continue Normal Boot	The system attempts to boot to devices starting with the first item in the boot order. If the boot attempt fails, the system continues with the next item in the boot order until the boot is successful or no more boot options are found.
One-shot UEFI Boot Menu	Enables you to access the boot menu, where you can select a one-time boot device to boot from.
Launch System Setup	Enables you to access System Setup.
System Utilities	Enables you to launch the System Utilities menu such as Launch Diagnostics, BIOS update File Explorer, Reboot System.

PXE boot

You can use the Preboot Execution Environment (PXE) option to boot and configure the networked systems remotely.

To access the **PXE boot** option, boot the system and then press F12 during POST instead of using standard Boot Sequence from BIOS Setup. It does not pull any menu or allows managing of network devices.

Minimum to POST and system management configuration validation

This section describes the minimum to POST system requirement and system management configuration validation of the Dell system.

Topics:

- [Minimum configuration to POST](#)

Minimum configuration to POST

The components that are listed below are the minimum configuration to POST:

- One CPU on CPU0
- One memory module (DIMM) in slot A1
- One power supply unit
- Host Processor Module (HPM)* + Data Center Secured Control Module (DC-SCM)

 **NOTE:** HPM is also known as System Board.

Configuration validation

The new generation of Dell systems have added interconnect flexibility and iDRAC management features to collect precise system configuration information and report configuration errors.

When the system is powered on, information about installed cables, risers, backplanes, power supplies, floating card (fPERC, adapter PERC, BOSS), and processor is obtained from the CPLD and backplane memory maps are analyzed. This information forms a unique configuration, which is compared with one of the qualified configurations that are stored in a table that is maintained by iDRAC.

One or more sensors are assigned to each of the configuration elements. During POST, any configuration validation error is logged in the System event log (SEL) log. The reported events are categorized in the configuration validation error table.

Table 54. Configuration validation error

Error	Description	Possible cause and recommendations	Example
Config Error	A configuration element within the closest match contains something that is unexpected and does not match any Dell qualified configuration.	Wrong configuration	Config Error: Backplane Cable PLANAR_SL1 and BP_DST_SA1
		The element reported in HWC8010 errors are assembled incorrectly. Verify element (cable, riser, and so on) placement in the system.	Config Error : Backplane Cable PLANAR_SL3 and BP_DST_PA1
Config Missing	iDRAC found a configuration element missing within the closest match detected.	A missing element or cable is reported in HWC8010 error logs. Install the missing element (cable, riser, and so on).	Config Missing : Backplane Cable PLANAR_SL3 and BP_DST_SA1
Comm Error	A configuration element is not responding to iDRAC using the management interface while running an inventory check.	System management sideband communication	Comm Error: Backplane 0
		Unplug AC Power, reseal the element and replace the element if the problem persists.	

Installing and removing system components

Topics:

- Safety instructions
- Before working inside your system
- After working inside your system
- Recommended tools
- Optional front metal bezel
- System cover
- Air shroud
- Cooling fans
- Drive backplane cover
- Drives
- Drive backplane
- Side wall brackets
- PERC module
- Cable routings
- System memory
- Direct Liquid Cooling (DLC) module mid bracket
- Processor and heat sink
- Expansion cards and expansion card risers
- M.2 SSD module
- Optional BOSS-N1 DC-MHS module
- Optional OCP NIC card
- Datacenter-Secure Control Module (DC-SCM)
- Attic board
- Optional internal USB port
- System battery
- Intrusion switch
- Power supply unit
- Trusted Platform Module
- HPM board
- Control panel

Safety instructions

 **CAUTION:** Whenever you need to lift the system, get others to assist you. To avoid injury, do not attempt to lift the system by yourself.

 **CAUTION:** Ensure that two or more people lift the system horizontally from the box and place it on a flat surface, rack lift, or into the rails.

 **WARNING:** Opening or removing the system cover while the system is powered on may expose you to a risk of electric shock.

 **WARNING:** Do not operate the system without the cover for a duration exceeding five minutes. Operating the system without the system cover can result in component damage.

 **CAUTION:** Many repairs may only be done by a certified service technician. You should only perform troubleshooting and simple repairs as authorized in your product documentation, or as directed by the online or

telephone service and support team. Damage due to servicing that is not authorized by Dell is not covered by your warranty. Read and follow the safety instructions that are shipped with your product.

NOTE: It is recommended that you always use an antistatic mat and antistatic strap while working on components inside the system.

CAUTION: To ensure proper operation and cooling, all system bays and fans must always be populated with a component or a blank.

NOTE: Only use certified Optical Fiber Transceiver Class 1 Laser Products.

CAUTION: Do not install GPUs, network cards, or other PCIe devices on your system that are not validated and tested by Dell. Damage caused by unauthorized and invalidated hardware installation will null and void the system warranty.

NOTE: Maximum operation pressure specified by the manufacturer is 43 PSI.

Before working inside your system

Prerequisites

Follow the safety guidelines listed in [Safety instructions](#).

Steps

1. Power off the system and all attached peripherals.
2. Disconnect the system from the electrical outlet, and disconnect the peripherals.
3. If applicable, remove the system from the rack.

For more information, see the *Rail Installation Guide* relevant to your rail solutions at [PowerEdge Manuals](#).

4. Remove the system cover.

After working inside your system

Prerequisites

Follow the safety guidelines listed in [Safety instructions](#).

Steps

1. Replace the system cover.
2. If applicable, install the system into the rack.
For more information, see the *Rail Installation Guide* relevant to your rail solutions at [PowerEdge manuals](#).
3. Reconnect the peripherals and connect the system to the electrical outlet, and then power on the system.

Recommended tools

You may need some or all the following tools to perform the removal and installation procedures:

- Phillips 1 screwdriver
- Phillips 2 screwdriver
- Torx T20 screwdriver
- 5 mm hex nut screwdriver
- Plastic scribe
- 1/4-inch flat blade screwdriver
- Wrist grounding strap that is connected to the ground
- ESD mat

- Needle-nose pliers

Optional front metal bezel

Removing the front bezel

The procedure to remove the front bezel.

Prerequisites

1. Follow the safety guidelines listed in the [Safety instructions](#).
2. Keep the bezel key handy.

Steps

1. Unlock the bezel.
2. Press the release button, and disengage the left end of the bezel.
3. Unhook the right end, and remove the bezel.

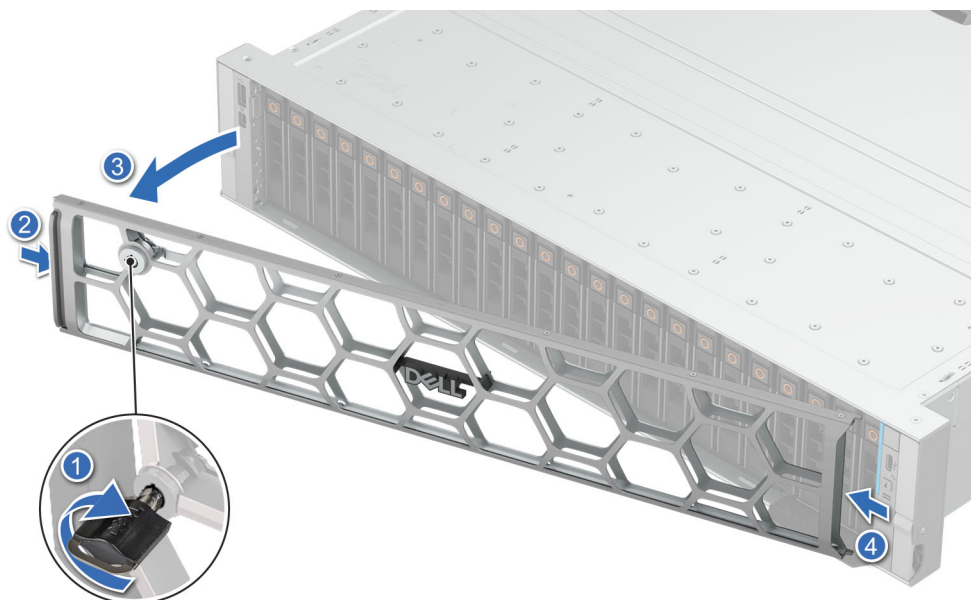

Figure 31. Removing the front bezel

Next steps

Replace front bezel.

Installing the front bezel

The procedure to install the front bezel.

Prerequisites

1. Follow the safety guidelines listed in the [Safety instructions](#).
2. Locate and remove the bezel key.

Steps

1. Align and insert the tabs on the bezel into the slots on the system.
2. Press the bezel until the release button clicks in place.
3. Lock the bezel.

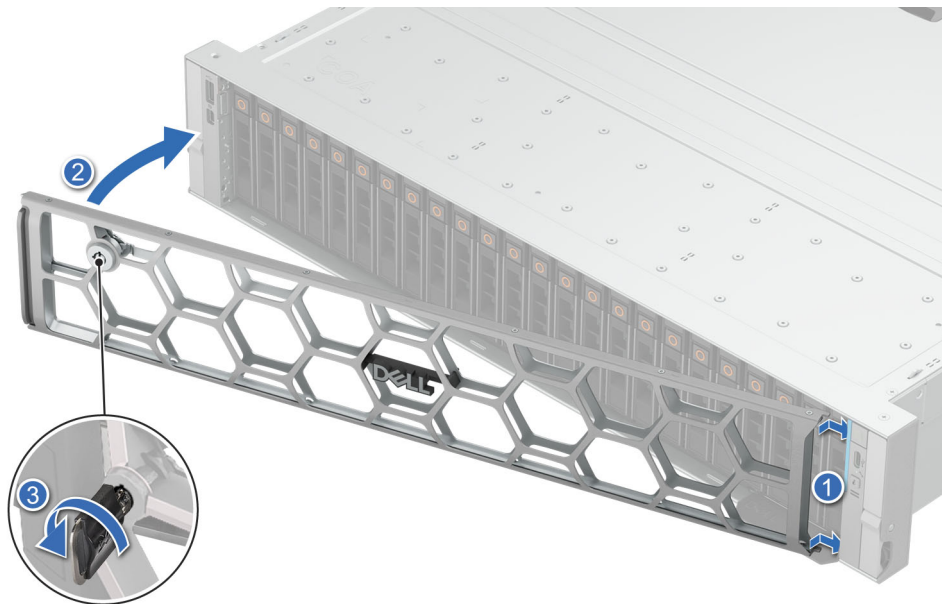

Figure 32. Installing the front bezel

System cover

Removing the system cover

Prerequisites

1. Follow the safety guidelines listed in the [Safety instructions](#).
2. Power off the system, and any attached peripherals.
3. Disconnect the system from the electrical outlet and peripherals.

Steps

1. Using a 1/4-inch flat head or a Phillips 2 screwdriver, rotate the lock counterclockwise to the unlocked position.
2. Lift the release latch until the system cover slides back.
3. Lift the cover from the system.



Figure 33. Removing the system cover

Next steps

1. [Replace the system cover.](#)

Installing the system cover

Prerequisites

1. Follow the safety guidelines listed in the [Safety instructions](#).
2. Follow the procedure listed in [Before working inside your system](#).
3. Ensure that all internal cables are connected and routed properly, and no tools or extra parts are left inside the system.

Steps

1. Align the tabs on the system cover with the guide slots on the system and slide the system cover.
2. Close the system cover release latch.
3. Using a 1/4-inch flat head or Phillips 2 screwdriver, rotate the lock clockwise to the locked position.



Figure 34. Installing the system cover

Next steps

1. Follow the procedure listed in [After working inside your system](#).

Air shroud

Removing the left and right air shrouds

Prerequisites

CAUTION: Never operate your system with the air shroud removed. The system may get overheated quickly, resulting in shutdown of the system and loss of data.

1. Follow the safety guidelines listed in the [Safety instructions](#).
2. Follow the procedure listed in [Before working inside your system](#).
3. Remove the cables from the air shroud notch.

Steps

1. Press the latch on the air shroud.

NOTE: To remove the left air shroud, press the latch on the right air shroud in the opposite direction.

2. Hold the edges of the air shroud, lift the air shroud out of the system.

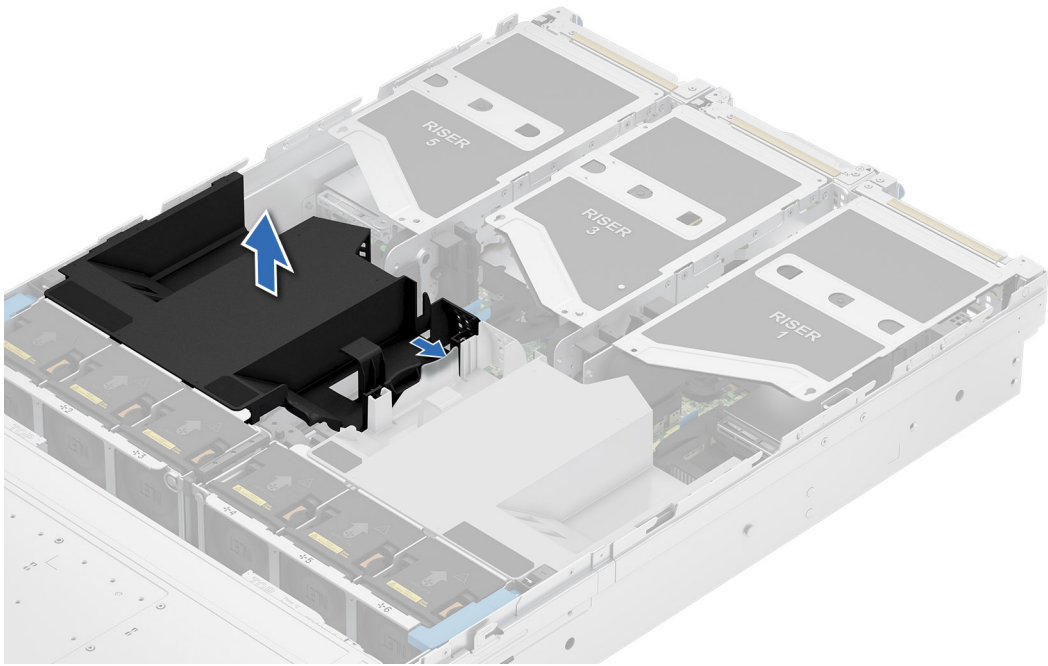

Figure 35. Removing the left air shroud

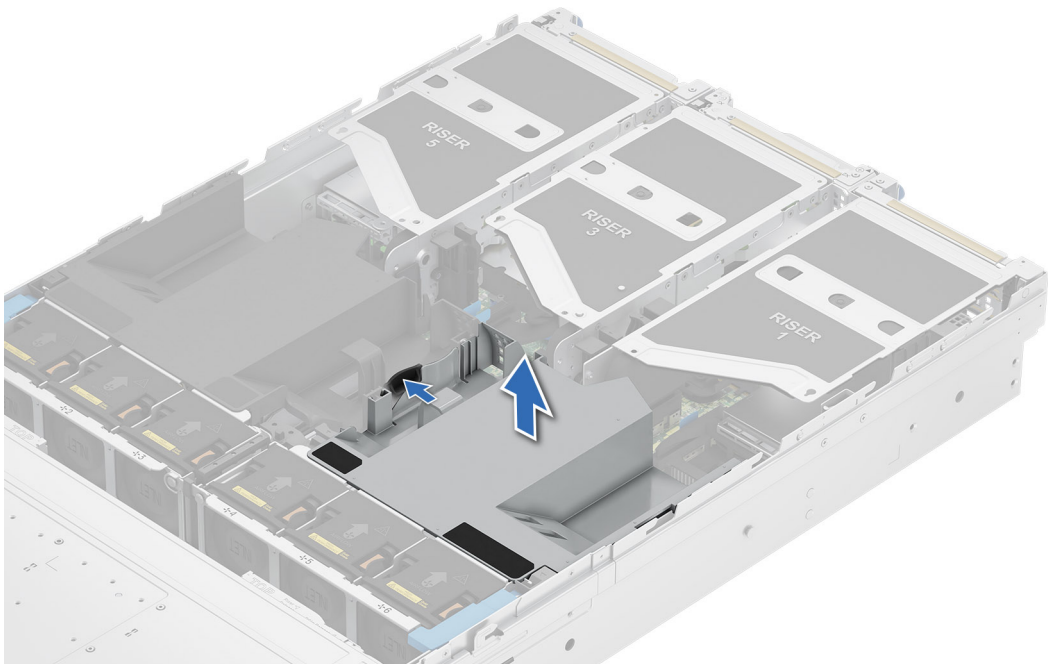

Figure 36. Removing the right air shroud

NOTE: The left and right air shrouds can also be removed together.

Next steps

1. Replace the left and right air shrouds.

Installing the left and right air shrouds

Prerequisites

1. Follow the safety guidelines listed in the [Safety instructions](#).
2. Follow the procedure listed in [Before working inside your system](#).
3. Remove the cables from the air shroud notch.

Steps

1. Align the slot on the air shroud with the tab on the left or right air shroud.
2. Lower the air shroud into the system until it is firmly seated.

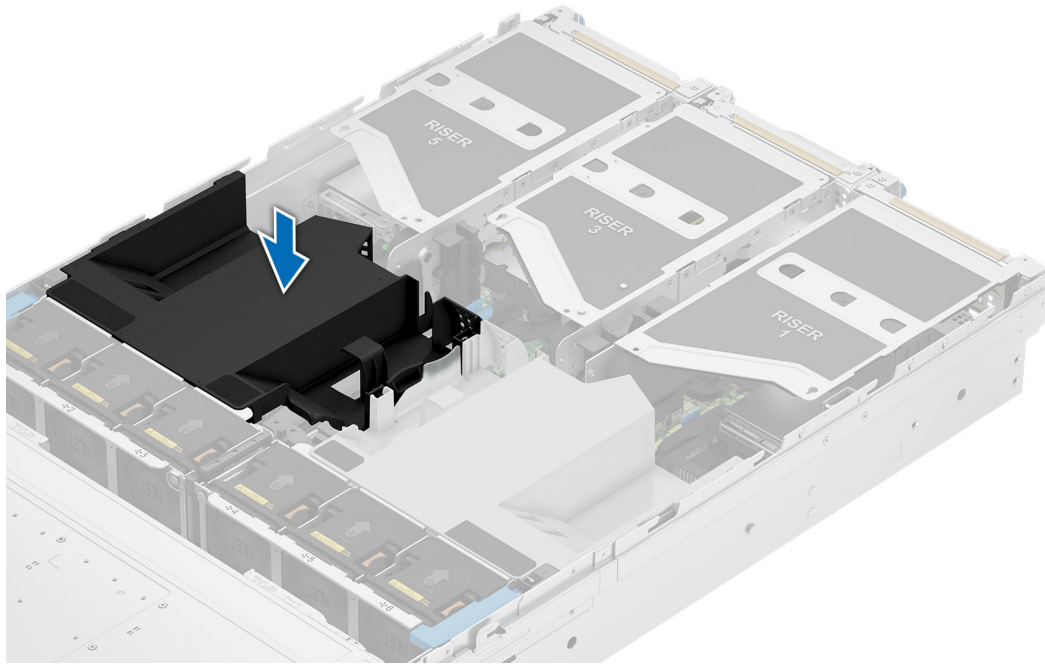

Figure 37. Installing the left air shroud

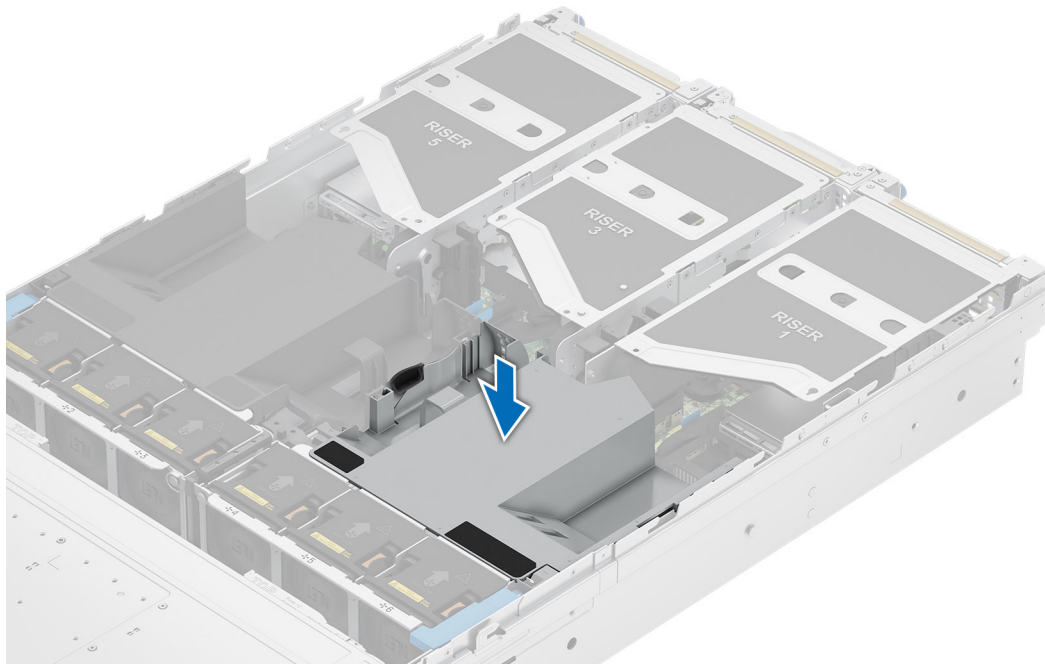

Figure 38. Installing the right air shroud

NOTE: The left and right air shrouds can also be installed together.

Next steps

1. Route the cables along the air shroud notch.
2. Follow the procedure listed in [After working inside your system](#).

Removing the wing air shroud

Prerequisites

CAUTION: Never operate your system with the air shroud removed. The system may get overheated quickly, resulting in shutdown of the system and loss of data.

1. Follow the safety guidelines listed in the [Safety instructions](#).
2. Follow the procedure listed in [Before working inside your system](#).
3. Remove the cables from the air shroud notch.

Steps

Hold the edges of the air shroud, lift the air shroud out of the system.

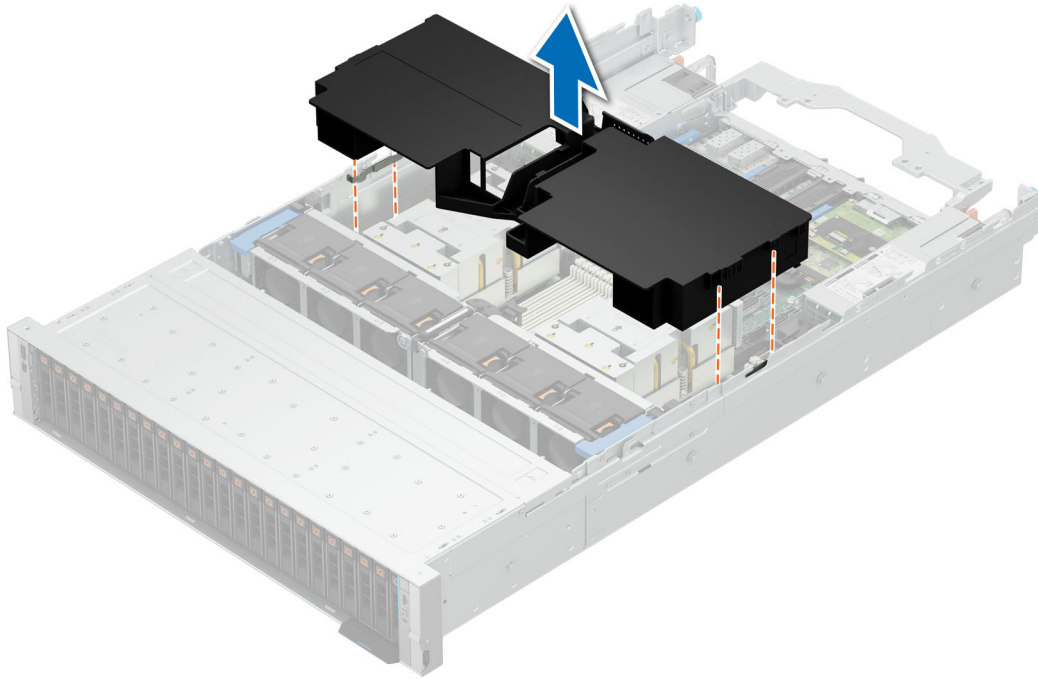

Figure 39. Removing the left air shroud

Next steps

1. [Replace the wing air shroud.](#)

Installing the wing air shroud

Prerequisites

1. Follow the safety guidelines listed in the [Safety instructions](#).
2. Follow the procedure listed in [Before working inside your system](#).
3. Remove the cables from the air shroud notch.

Steps

1. Align the slot on the air shroud with the standoff on the system.
2. Lower the air shroud into the system until it is firmly seated.

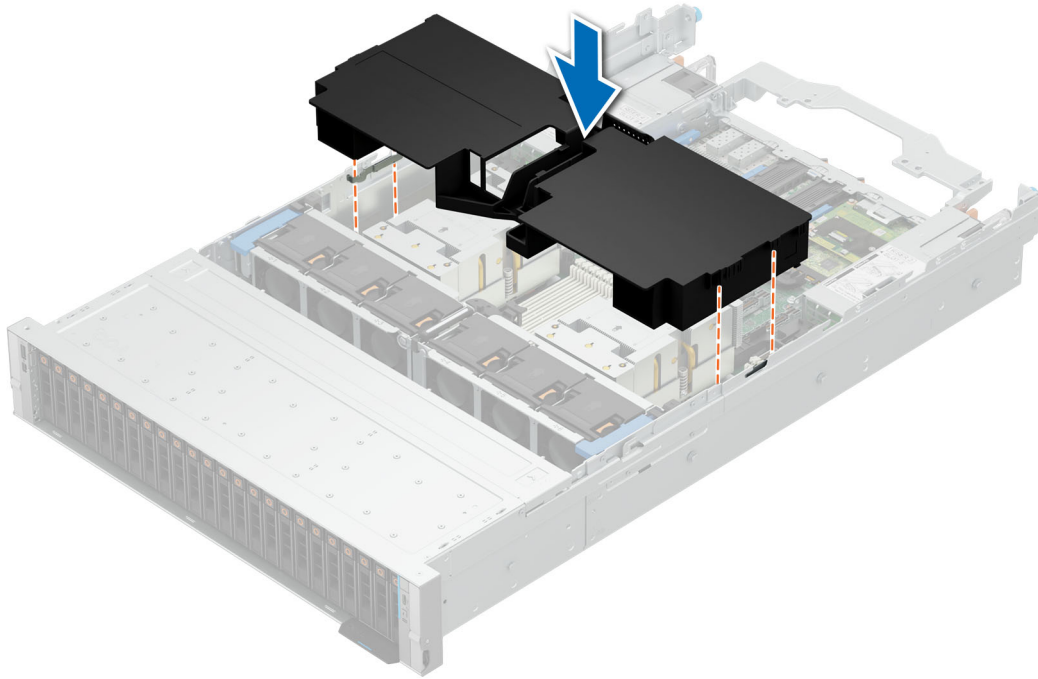

Figure 40. Installing the wing air shroud

Next steps

1. Route the cables along the air shroud notch.
2. Follow the procedure listed in [After working inside your system](#).

Cooling fans

Removing a cooling fan

Prerequisites

1. Follow the safety guidelines listed in the [Safety instructions](#).
2. Follow the procedure listed in [Before working inside your system](#).

NOTE: The procedure for removing a high-performance silver grade (HPR SLVR), high-performance gold (HPR Gold), or high-performance platinum (HPR PLTM) fan is identical.

Steps

Press the orange release tab and lift the cooling fan to disconnect the fan from the connector on the fan board.

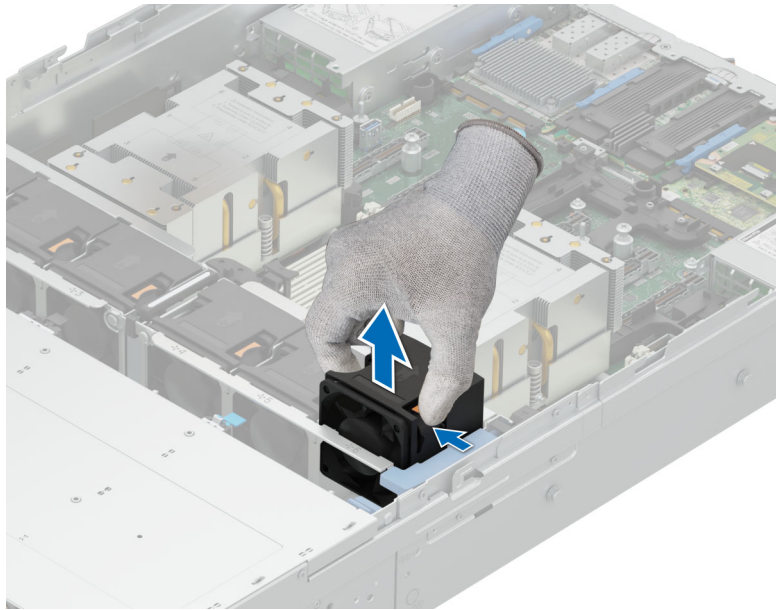

Figure 41. Removing a cooling fan

Next steps

1. [Replace a cooling fan.](#)

Installing a cooling fan

Prerequisites

1. Follow the safety guidelines listed in the [Safety instructions](#).
2. Follow the procedure listed in [Before working inside your system](#).

NOTE: The procedure for removing a high-performance silver grade (HPR SLVR), high-performance gold (HPR Gold), or high-performance platinum (HPR PLTM) fan is identical.

Steps

Align and lower the cooling fan into the cooling fan assembly until the fan clicks into place.

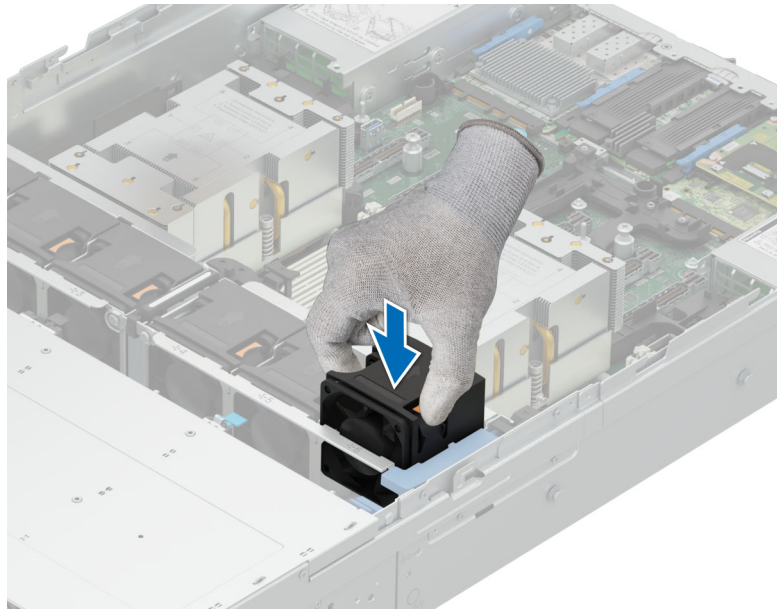

Figure 42. Installing a cooling fan

Next steps

1. Follow the procedure listed in [After working inside your system](#).

Removing the cooling fan cage assembly

Prerequisites

1. Follow the safety guidelines listed in the [Safety instructions](#).
2. Follow the procedure listed in the [Before working inside your system](#).
3. If required, remove the cables that pass through the cooling fan cage assembly.
4. If required, [remove the air shroud](#).

Steps

1. Lift the blue release levers to unlock the cooling fan cage assembly from the system.
2. Hold the release levers, and lift the cooling fan cage assembly away from the system.

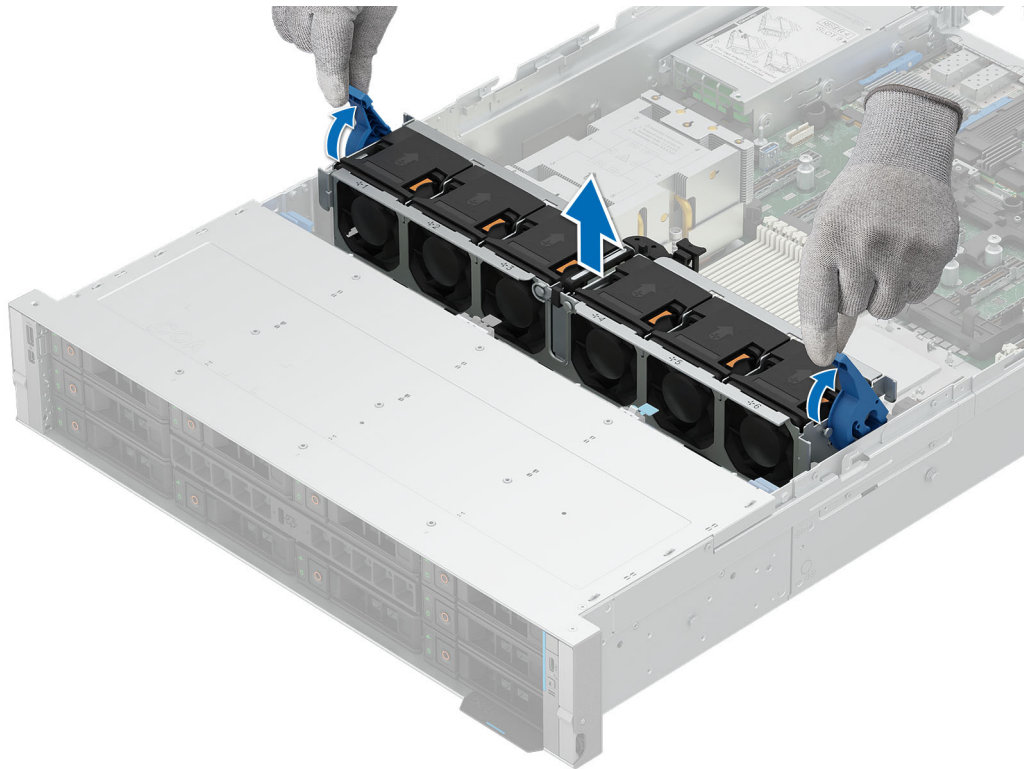

Figure 43. Removing the cooling fan cage assembly

Next steps

1. [Replace the cooling fan cage assembly.](#)

Installing the cooling fan cage assembly

Prerequisites

1. Follow the safety guidelines listed in the [Safety instructions](#).

CAUTION: Before installing the cooling fan cage assembly, ensure that the cables inside the system are properly installed and retained by the cable retention brackets. Cables that are not properly installed may be damaged.

2. Follow the procedure listed in [Before working inside your system](#).
3. If required, remove the cables that pass through the cooling fan cage assembly.
4. If installed, [remove the air shroud](#).

Steps

1. Holding the blue release lever of the cooling fan cage, align the guide rails with the guides on the system.
2. Lower the cooling fan cage assembly into the system until seated firmly.
3. Lower the blue release lever and press to lock the cooling fan cage assembly into the system.

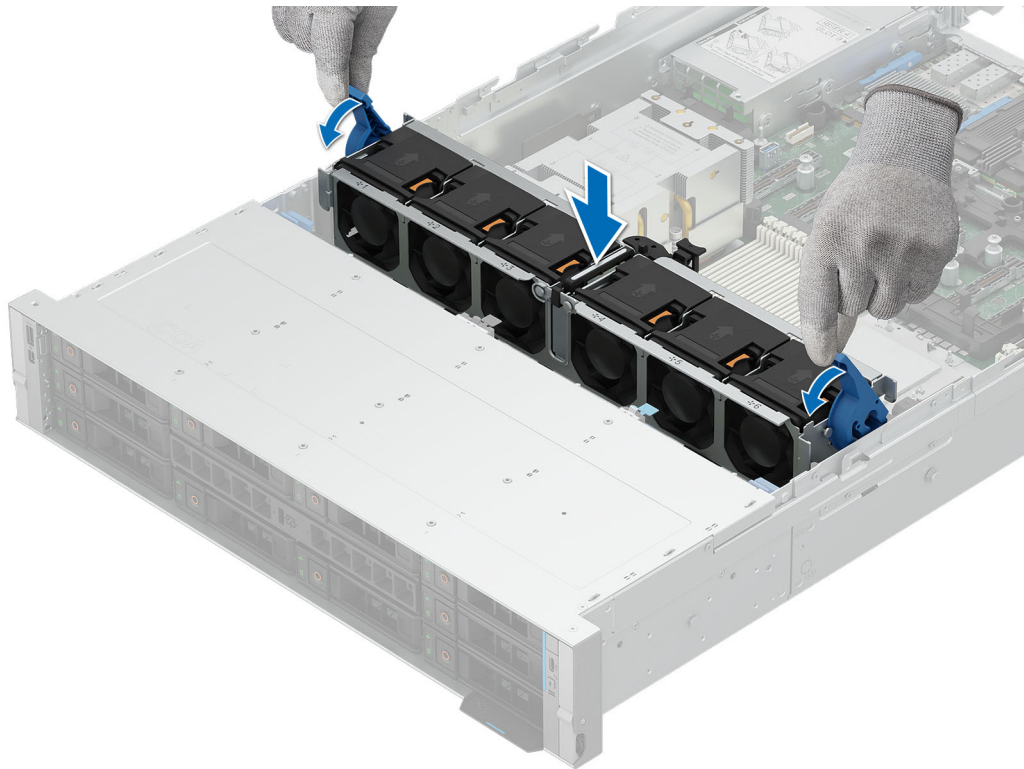

Figure 44. Installing the cooling fan cage assembly

Next steps

1. If removed, [install the air shroud](#) .
2. Follow the procedure listed in [After working inside your system](#).

Drive backplane cover

Removing the drive backplane cover

Prerequisites

1. Follow the safety guidelines listed in the [Safety instructions](#).
2. Follow the procedure listed in [Before working inside your system](#).

Steps

1. Slide the drive backplane cover in the direction of the arrows marked on the drive backplane cover.
2. Lift the drive backplane cover from the system.

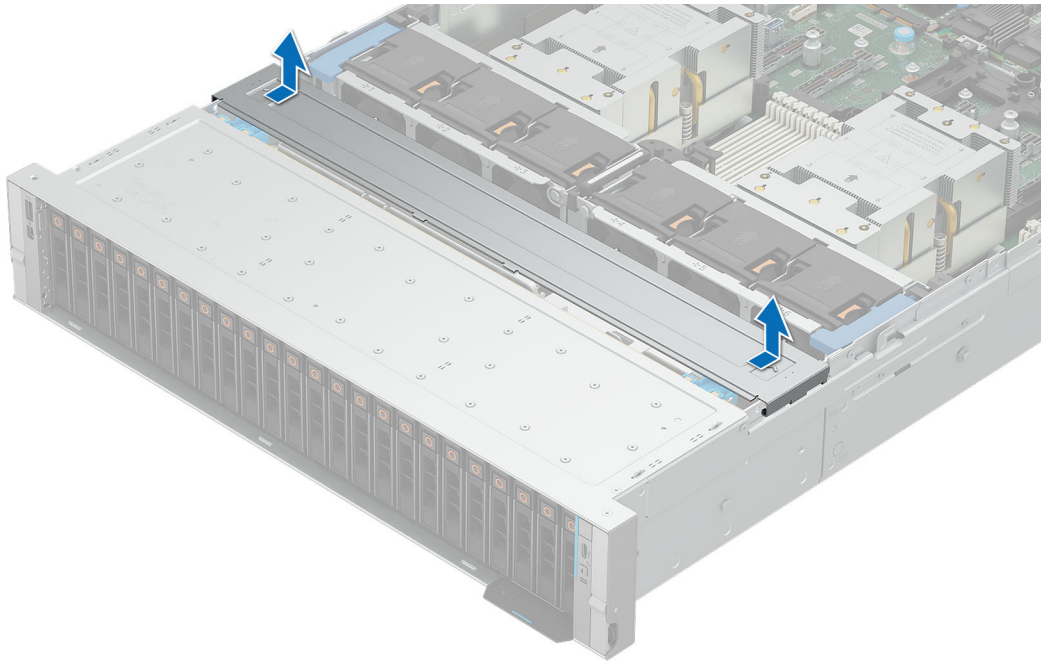

Figure 45. Removing the drive backplane cover

Next steps

1. [Replace the drive backplane cover.](#)

Installing the drive backplane cover

Prerequisites

1. Follow the safety guidelines listed in the [Safety instructions](#).
2. Follow the procedure listed in [Before working inside your system](#).

Steps

1. Align the drive backplane cover with the guide slots on the system.
2. Slide the drive backplane cover to the front of the system until the drive backplane cover fits into place.

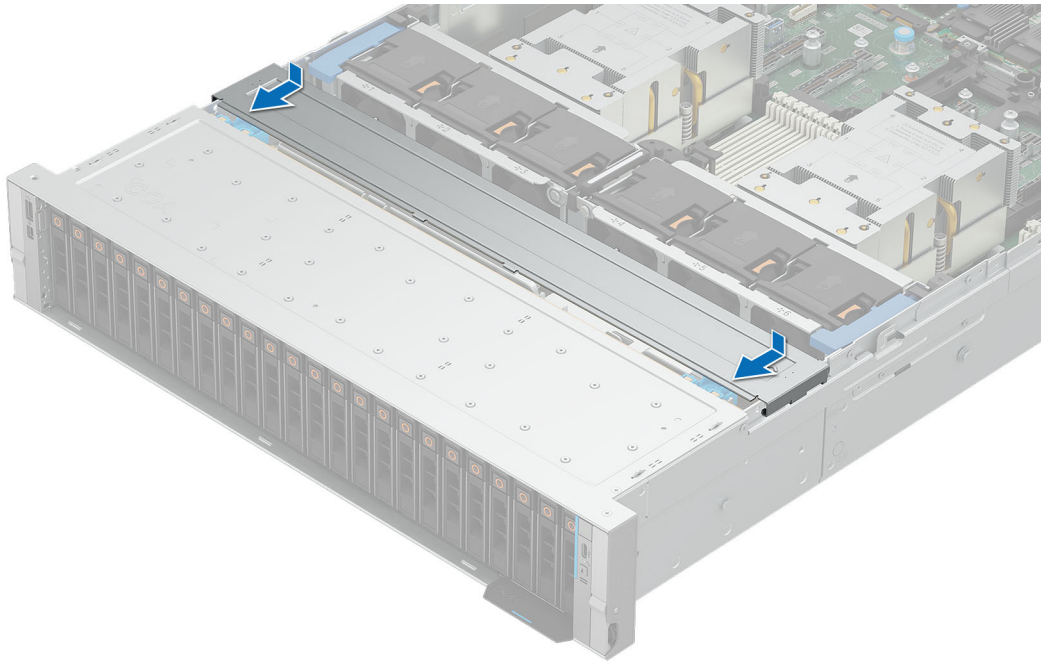

Figure 46. Installing the drive backplane cover

Next steps

1. Follow the procedure listed in [After working inside your system](#).

Drives

Removing a drive blank

Prerequisites

1. Follow the safety guidelines listed in the [Safety instructions](#).
2. If installed, [remove the front bezel](#).

CAUTION: To maintain proper system cooling, drive blanks must be installed in all empty drive slots.

Steps

1. Press the release button, and slide the drive blank out of the drive slot.

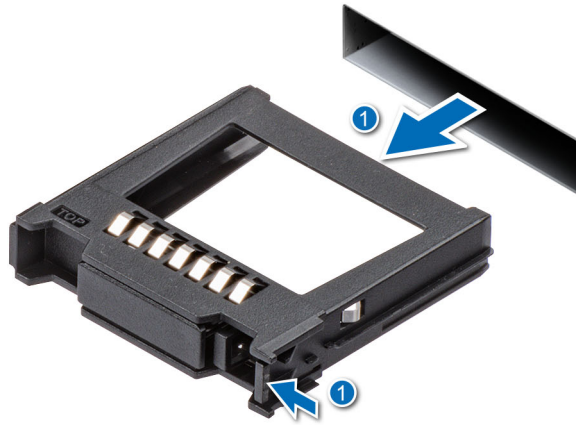

Figure 47. Removing a drive blank

2. For EDSFF E3.S drive blank, Lift the release button, and slide the drive blank out of the drive slot.

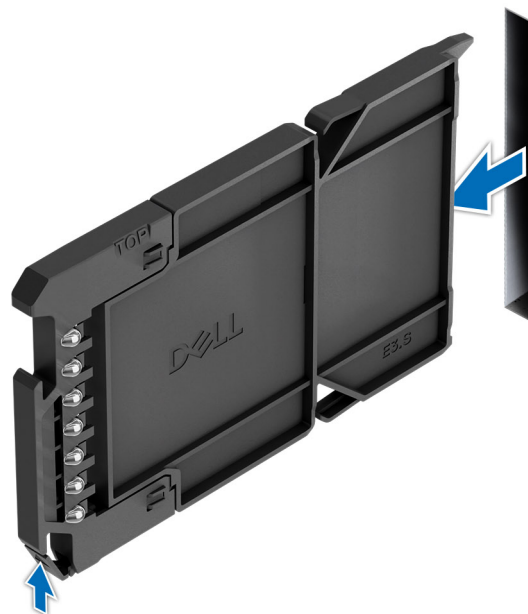

Figure 48. Removing an EDSFF E3.S drive blank

Next steps

1. [Replace the drive blank.](#)

Installing the drive blank

Prerequisites

1. Follow the safety guidelines listed in the [Safety instructions](#).
2. If installed, [remove the front bezel](#).

Steps

1. Insert the drive blank into the drive slot until the release button clicks into place.

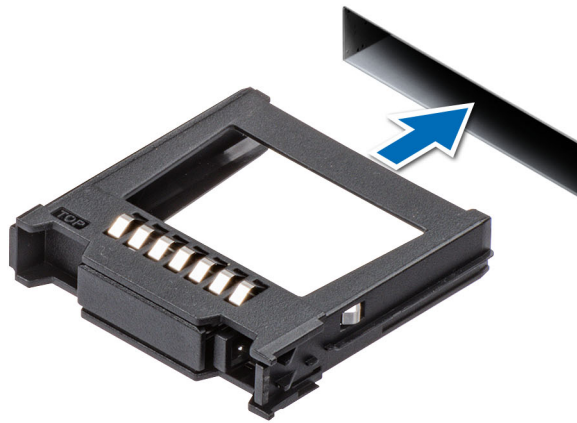

Figure 49. Installing a drive blank

2. For EDSFF E3.S drive blank, slide the drive blank into the drive slot until the release button clicks into place.



Figure 50. Installing an EDSFF E3.S drive blank

Next steps

1. If removed, [install the front bezel](#).

Removing the drive carrier

Prerequisites

1. Follow the safety guidelines listed in [Safety instructions](#).
2. [Remove the front bezel](#).
3. Using the management software, prepare the drive for removal. If the drive is online, the green activity or fault indicator flashes while the drive is turning off. When the drive indicators are off, the drive is ready for removal. For more information, see the storage controller documentation.

CAUTION: Before attempting to remove or install a drive while the system is running, see the documentation for the storage controller card to ensure that the host adapter is configured correctly to support drive removal and insertion.

CAUTION: To prevent data loss, ensure that your operating system supports drive installation. See the documentation supplied with your operating system.

Steps

1. Press the release button to open the drive carrier release handle.
2. Holding the drive carrier release handle, slide the drive carrier out of the drive slot.

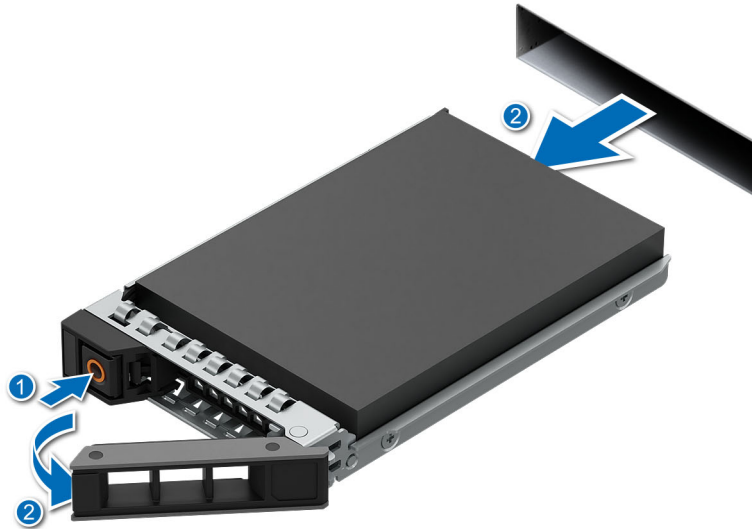

Figure 51. Removing a drive carrier

3. For EDSFF E3.S drive carrier, Lift the release button to open the drive carrier release handle.
4. Holding the drive carrier release handle, slide the drive carrier out of the drive slot.

NOTE: If you are not replacing the drive immediately, install an EDSFF E3.S drive blank in the empty drive slot to maintain proper system cooling.

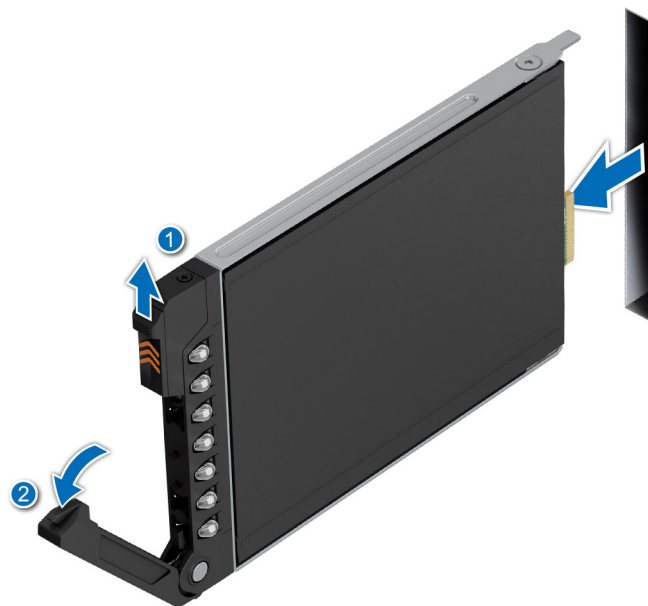

Figure 52. Removing an EDSFF E3.S drive carrier

Next steps

Replace the EDSFF E3.S drive or an EDSFF E3.S drive blank.

Installing a drive carrier

Prerequisites

- CAUTION:** Before removing or installing a drive while the system is running, see the [Storage Controller Manuals](#) documentation for the storage controller card to ensure that the host adapter is configured correctly to support drive removal and insertion.
- CAUTION:** Combining SAS and SATA drives in the same RAID volume is not supported.
- CAUTION:** When installing a drive, ensure that the adjacent drives are fully installed. Inserting a drive carrier and attempting to lock its handle next to a partially installed carrier can damage the partially installed carrier's shield spring and make it unusable.
- NOTE:** Ensure that the drive carrier's release handle is in the open position before inserting the carrier into the slot.
- CAUTION:** To prevent data loss, ensure that your operating system supports hot-swap drive installation. See the documentation supplied with your operating system.
- CAUTION:** When a replacement hot swappable drive is installed and the system is powered on, the drive automatically begins to rebuild. Ensure that the replacement drive is blank or contains data that you wish to overwrite. Any data on the replacement drive is immediately lost after the drive is installed.

1. Follow the safety guidelines listed in [Safety instructions](#).
2. Remove the drive carrier or remove the drive blank when you want to assemble the drive into the system.

Steps

1. Slide the drive carrier into the drive slot.
2. Close the drive carrier release handle to lock the drive in place.

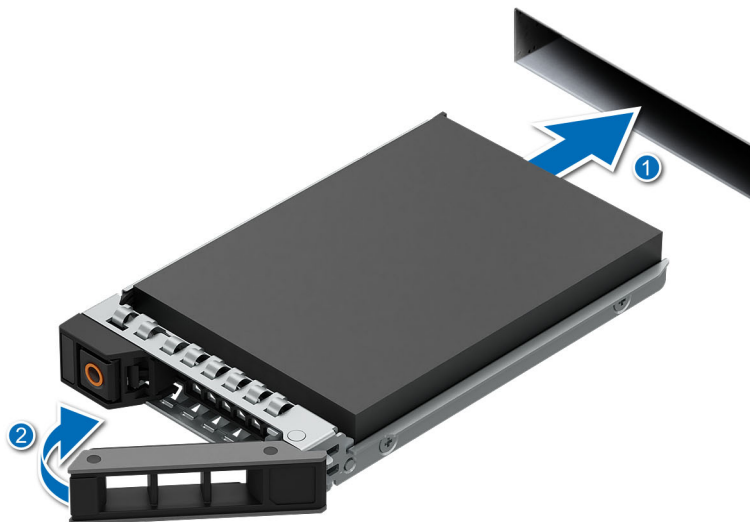

Figure 53. Installing a drive carrier

3. For EDSFF E3.S drive carrier, slide the drive carrier into the drive slot and push until the drive connects with the backplane.
4. Close the drive carrier release handle to lock the drive in place.

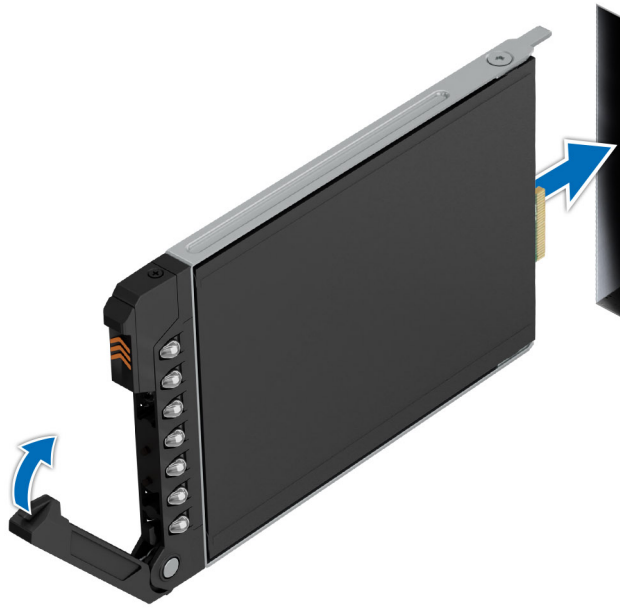

Figure 54. Installing an EDSFF E3.S drive carrier

Next steps

Install the front bezel.

Removing the drive from the drive carrier

Prerequisites

1. Follow the safety guidelines listed in the [Safety instructions](#).
2. If installed, [remove the front bezel](#).

Steps

1. Using a Phillips #1 screwdriver, remove the screws from the slide rails on the drive carrier.

 **NOTE:** If the SSD carrier has a Torx screw, use Torx 6 (for 2.5-inch drive) screwdriver to remove the drive.



2. Lift the drive out of the drive carrier.

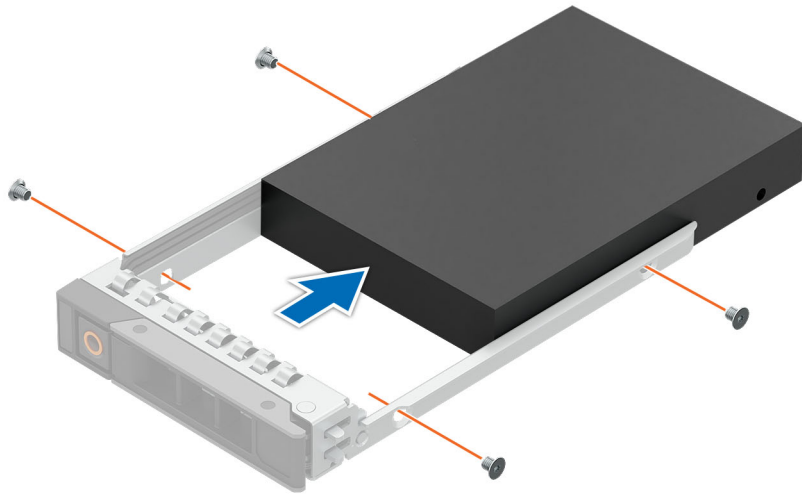

Figure 55. Removing the drive from the drive carrier

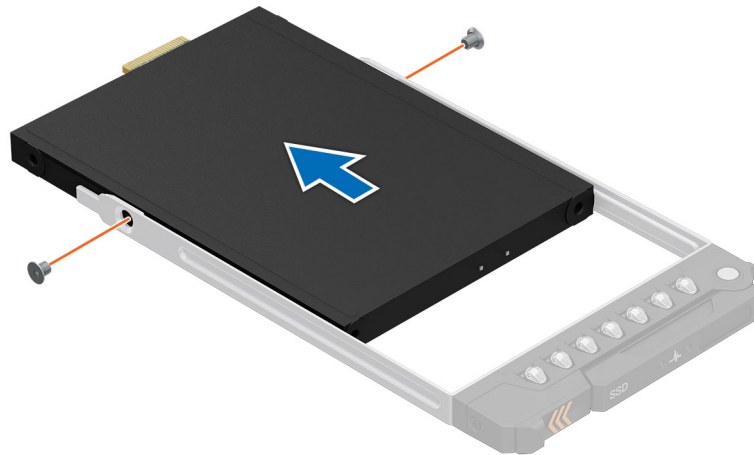

Figure 56. Removing an EDSFF E3.S drive from the drive carrier

Next steps

Install the drive into the drive carrier.

Installing the drive into the drive carrier

Prerequisites

1. Follow the safety guidelines listed in the [Safety instructions](#).
2. If installed, [remove the front bezel](#).
3. [Remove the drive blank](#).

Steps

1. Insert the drive into the drive carrier with the drive connector facing towards the rear of the carrier.
2. Align the screw holes on the drive with the screws holes on the drive carrier.
3. Using a Phillips #1 screwdriver, secure the drive to the drive carrier with the screws.

NOTE: When installing a drive into the drive carrier, ensure that the screws are torqued to 4 lbf-in.

NOTE: If the SSD carrier has a Torx screw, use Torx 6 (for 2.5-inch drive) screwdriver to install the drive.

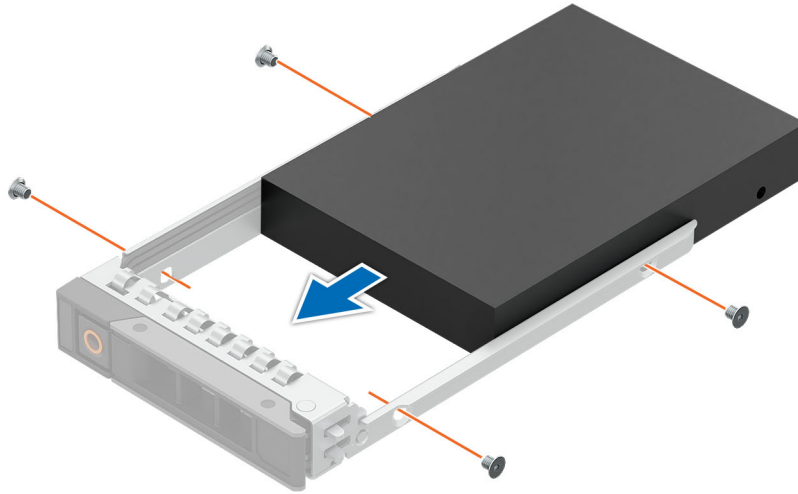

Figure 57. Installing a drive into the drive carrier

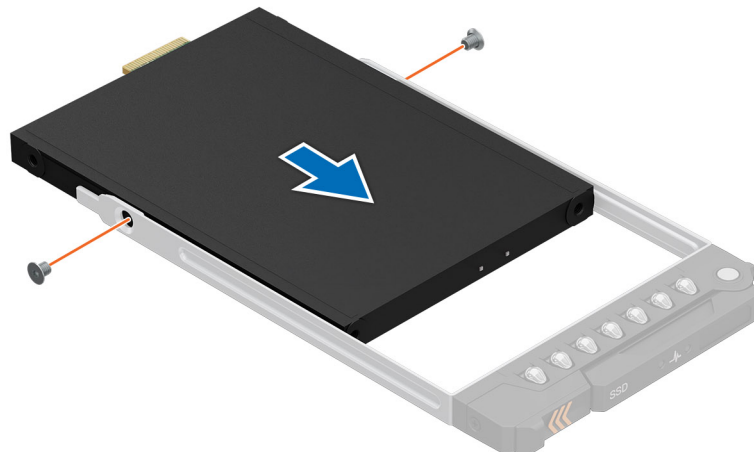

Figure 58. Installing an EDSFF E3.S drive into the drive carrier

Next steps

1. [Install the drive carrier.](#)
2. If removed, [install the front bezel.](#)

Drive backplane

This is a service technician replaceable part only.

Drive backplane

Depending on your system configuration, the drive backplanes that are supported are listed here:

Table 55. Supported backplane options

System	Supported drives options
PowerEdge R7725	<ul style="list-style-type: none"> • 3.5-inch SAS/SATA backplane • 2.5-inch (x8) Universal backplane • EDSFF E3.S (x8) NVMe backplane

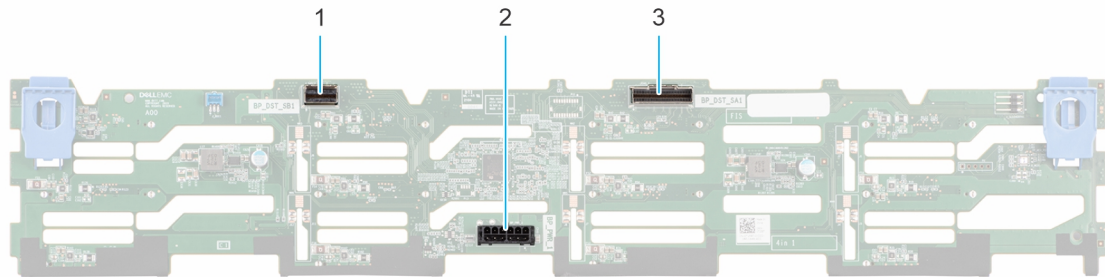

Figure 59. 12 x 3.5-inch SAS/SATA backplane

1. BP_DST_SB1 (PERC to backplane)
2. BP_PWR_1 (backplane power cable to HPM board)
3. BP_DST_SA1 (PERC to backplane)

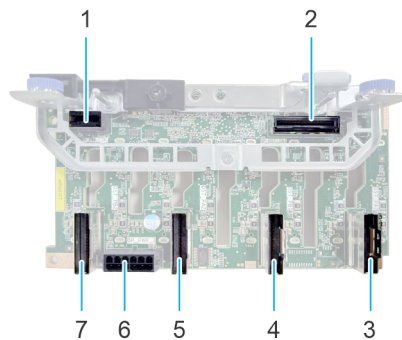

Figure 60. 8 x 2.5-inch Universal drive backplane

- | | |
|-------------------------------------|--|
| 1. BP_PWR_CTRL | 2. BP_DST_SA1 (PERC to backplane) |
| 3. BP_DST_PA1 (PCIe/NVMe connector) | 4. BP_DST_PB1 (PCIe/NVMe connector) |
| 5. BP_DST_PA2 (PCIe/NVMe connector) | 6. BP_PWR_1 (backplane power cable to HPM board) |
| 7. BP_DST_PB2 (PCIe/NVMe connector) | |

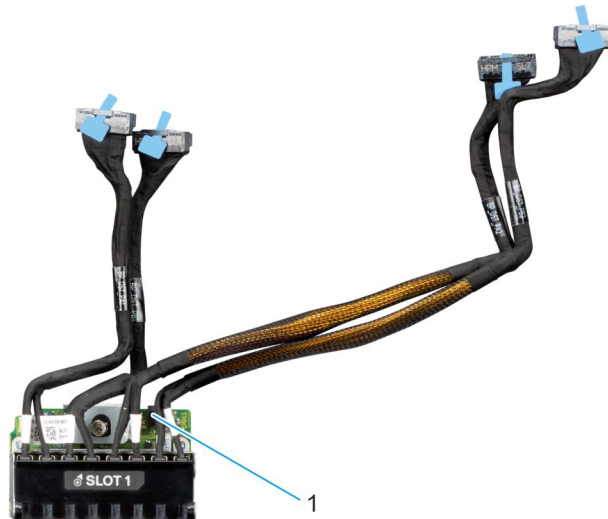

Figure 61. EDSFF E3.S NVMe drive backplane

1. BP_PWR_1 (backplane power cable to HPM board)

Removing the EDSFF E3.S backplane module

Prerequisites

1. Follow the safety guidelines listed in the [Safety instructions](#).
2. Follow the procedure listed in the [Before working inside your system](#).
3. If installed, [remove the front bezel](#).
4. [Remove the air shroud](#).
5. [Remove the drive backplane cover](#).
6. [Remove the cooling fan cage assembly](#).
7. [Remove the EDSFF E3.S drives](#).
8. Disconnect the power cable and other required cables, observe the cable routing.

NOTE: See [cable routing](#) section.

Steps

1. Using a Phillips 2 screwdriver, loosen the captive screws on the EDSFF E3.S backplane module.
2. Slide and remove the EDSFF E3.S backplane module from the system.

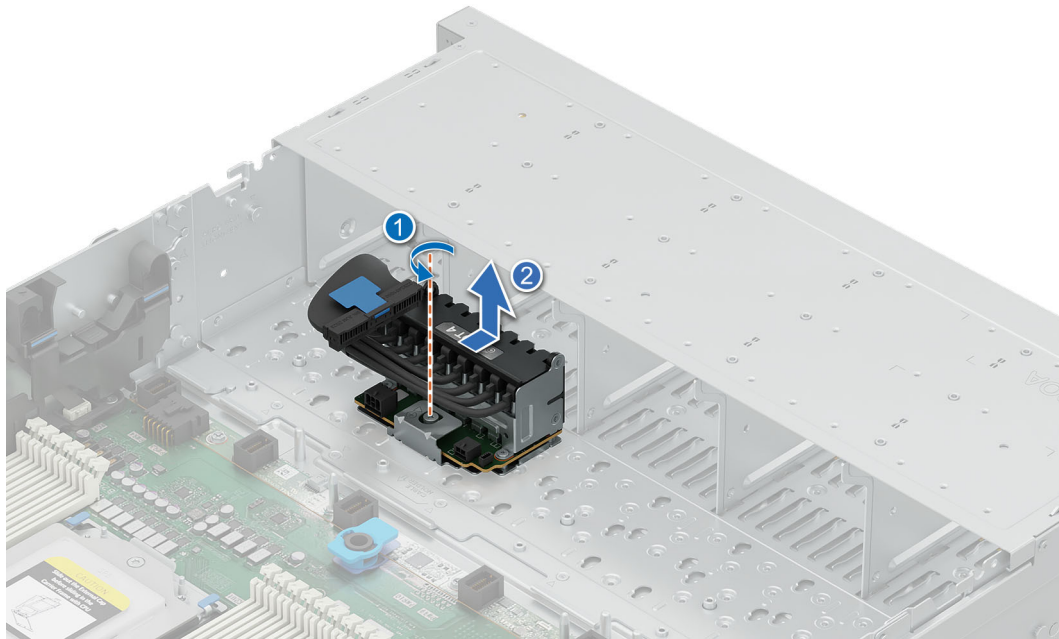

Figure 62. Removing the EDSFF E3.S backplane module

Next steps

1. Replace the EDSFF E3.S backplane module.

Installing the EDSFF E3.S backplane module

Prerequisites

1. Follow the safety guidelines listed in the [Safety instructions](#).
2. Follow the procedure listed in the [Before working inside your system](#).
3. If installed, [remove the front bezel](#).
4. [Remove the air shroud](#).
5. [Remove the drive backplane cover](#).
6. [Remove the cooling fan cage assembly](#).
7. [Remove the EDSFF E3.S drives](#).
8. Disconnect the power cable and other required cables, observe the cable routing.

NOTE: See [cable routing](#) section.

Steps

1. Align the guides on the EDSFF E3.S backplane module with the slots on the system.
NOTE: Locate and place the EDSFF E3.S backplane module on the unlocked position line.
2. Slide the EDSFF E3.S backplane module towards the front of the system, until it is firmly seated .
3. Using a Phillips 2 screwdriver, tighten the captive screws on the EDSFF E3.S backplane module.

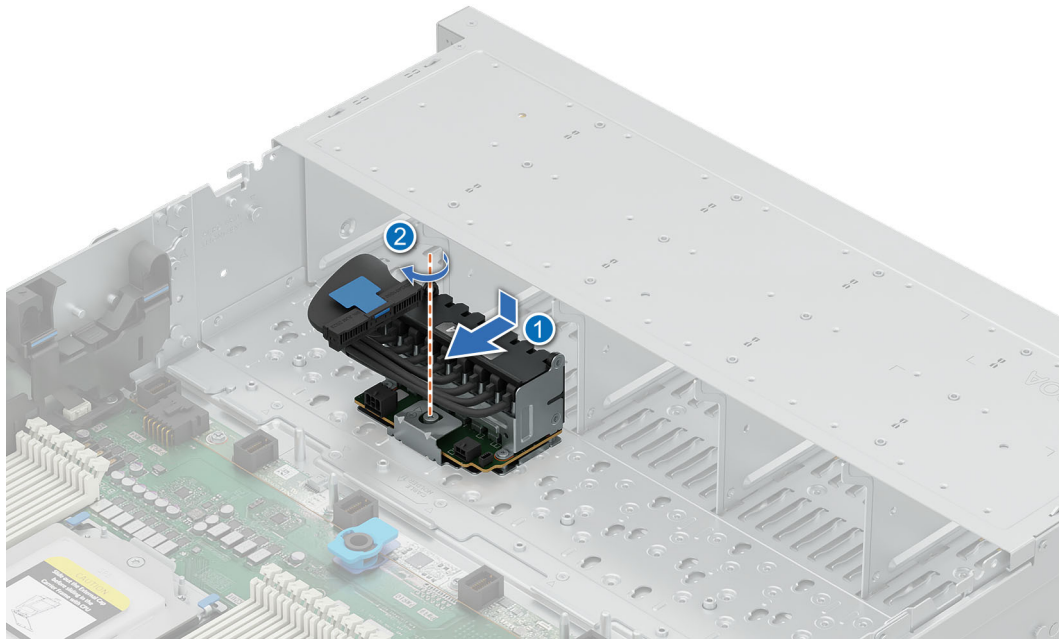

Figure 63. Installing the EDSFF E3.S backplane module

Next steps

1. Connect all the cables, and ensure that all the cables are routed through the respective cable clip.

NOTE: See [cable routing](#) section.

2. [Install the EDSFF E3.S drives](#) .
3. [Install the cooling fans cage assembly](#).
4. [Install the drive backplane cover](#).
5. [Install the air shroud](#).
6. If removed, [install the front bezel](#).
7. Follow the procedure listed in [After working inside your system](#).

Removing the drive backplane

Prerequisites

CAUTION: To prevent damage to the drives and backplane, remove the drives from the system before removing the backplane.

CAUTION: Note the number of each drive and temporarily label them before you remove the drive so that you can reinstall them in the same location.

NOTE: The procedure to remove the backplane is similar for all backplane configurations.

1. Follow the safety guidelines listed in the [Safety instructions](#).
2. Follow the procedure listed in the [Before working inside your system](#).
3. If installed, [remove the front bezel](#).
4. If installed, [remove the air shroud](#).
5. [Remove the drive backplane cover](#).
6. [Remove the cooling fan cage assembly](#).
7. [Remove the drives](#).
8. If required, [remove the front PERC module](#).
9. Observe and disconnect the drive backplane cables from the connector on the HPM board and backplane.

NOTE: See [cable routing](#) section for more information.

Steps

1. Press one or more release tabs to disengage the drive backplane from the hooks on the system.
2. Lift and pull the drive backplane out of the system.

NOTE: To avoid damaging the backplane, remove the disconnected backplane cables from the cable routing clips before removing the backplane.

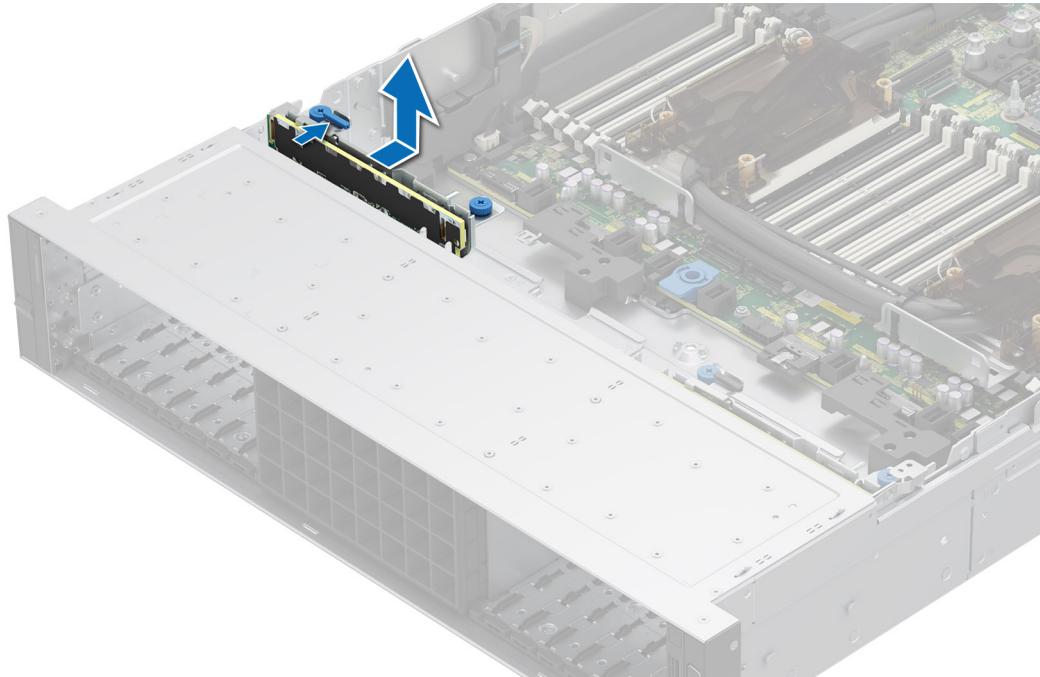

Figure 64. Removing the drive backplane

Next steps

1. [Replace the drive backplane.](#)

Installing the drive backplane

Prerequisites

1. Follow the safety guidelines listed in the [Safety instructions](#).
2. Follow the procedure listed in the [Before working inside your system](#).
3. If installed, [remove the front bezel](#).
4. If installed, [remove the air shroud](#).
5. [Remove the drive backplane cover](#).
6. [Remove the cooling fan cage assembly](#).
7. [Remove the drives](#).
8. If required, [remove the front PERC module](#).
9. Observe and disconnect the drive backplane cables from the connector on the HPM board and backplane.

NOTE: See [cable routing](#) section for more information.

NOTE: To avoid damaging the backplane, remove the disconnected backplane cables from the cable routing clips.

NOTE: Route the cable properly when you replace it to prevent the cable from being pinched or crimped.

Steps

1. Align the slots on the drive backplane with the guides on the system.
2. Slide the drive backplane into the guides on the system and lower the backplane until one or more blue release tabs clicks into place.

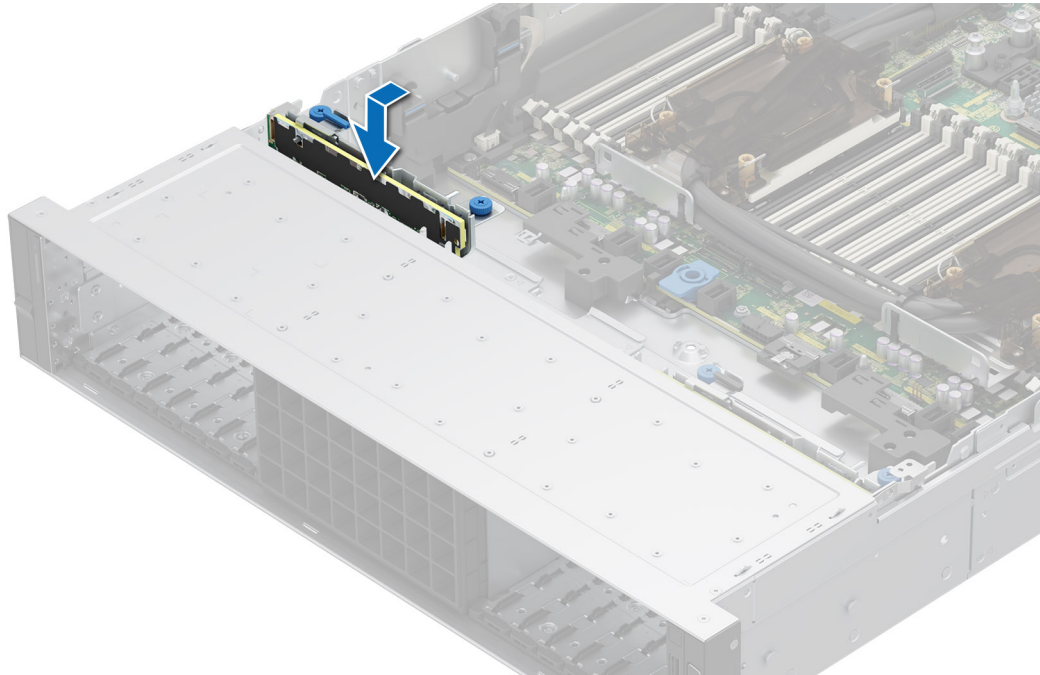

Figure 65. Installing the drive backplane

Next steps

1. Connect the drive backplane cables to the connectors on the HPM board and backplane.
2. [Install the drives.](#)
3. If required, [install the front PERC module.](#)
4. [Install the cooling fan cage assembly.](#)
5. [Install the drive backplane cover.](#)
6. [Install the air shroud.](#)
7. If removed, [install the front bezel.](#)
8. Follow the procedure listed in [After working inside your system.](#)

Side wall brackets

Removing the side wall bracket

There are two side wall brackets, one on either side of the system. The procedure to remove is similar.

Prerequisites

1. Follow the safety guidelines listed in the [Safety instructions.](#)
2. Follow the procedure listed in the [Before working inside your system.](#)
3. If required, [remove the drive backplane cover.](#)
4. If installed, [remove the air shroud.](#)
5. [Remove the cooling fan cage assembly.](#)

NOTE: Ensure that you note the routing of the cables as you remove them from the system board. Route the cables properly when you replace them to prevent the cables from being pinched or crimped.

Steps

1. Press the side tabs to release the side wall cable holder.

NOTE: Move the cables out of the side wall cable holder.

2. Press the center tab to release the bracket from the chassis, and lift it away from the system.

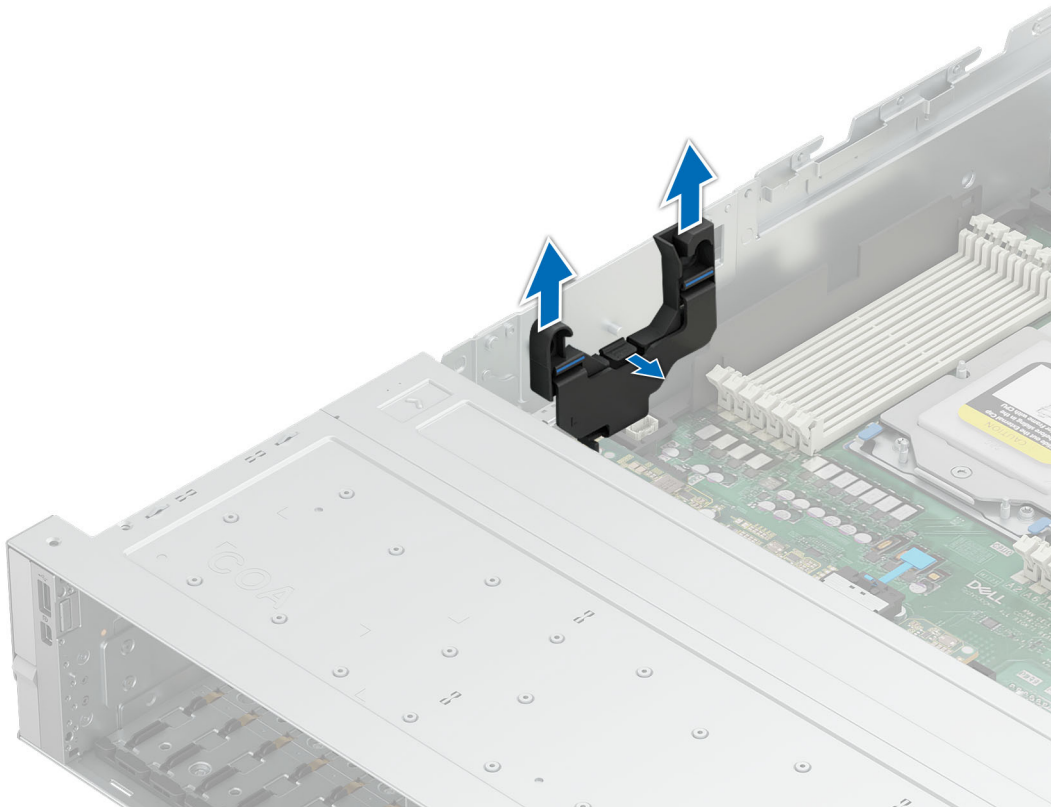

Figure 66. Removing the left side wall bracket

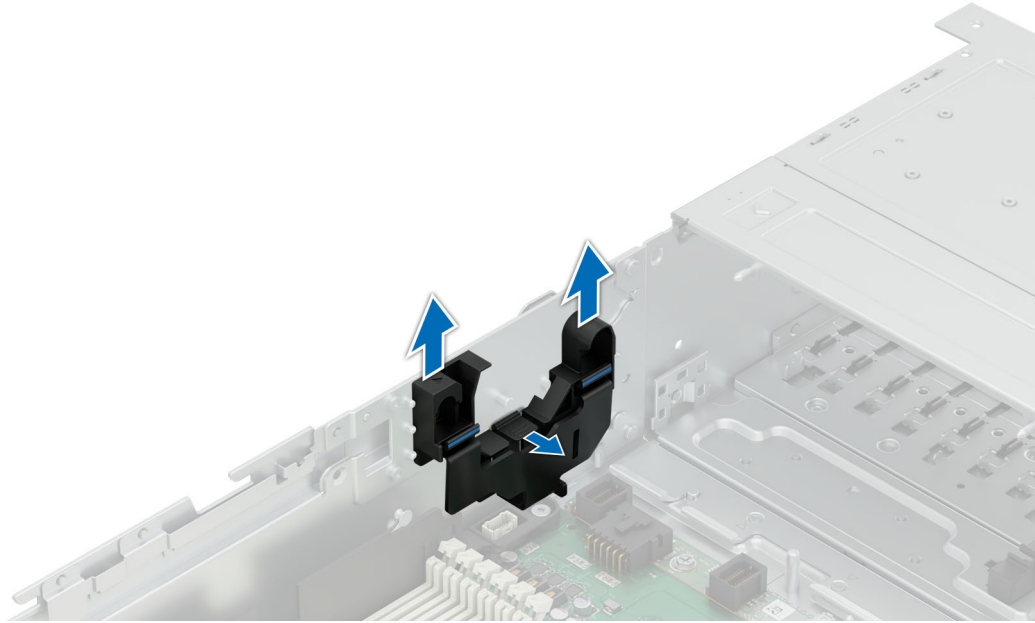

Figure 67. Removing the right side wall bracket

Next steps

1. [Replace the side wall bracket.](#)

Installing the side wall bracket

There are two side wall brackets on either side of the system. The procedure to install is similar.

Prerequisites

1. Follow the safety guidelines listed in the [Safety instructions](#).
2. Follow the procedure listed in the [Before working inside your system](#).
3. If required, [remove the drive backplane cover](#).
4. If installed, [remove the air shroud](#).
5. [Remove the cooling fan cage assembly](#).

i **NOTE:** Ensure that you note the routing of the cables as you remove them from the system board. Route the cables properly when you replace them to prevent the cables from being pinched or crimped.

Steps

1. Align the guide slots on the side wall bracket with the guides on the system and slide until the cover is seated firmly.

i **NOTE:** Route the cables through the side wall cable holder.

2. Close the side wall cable holder until the holder clicks into place.

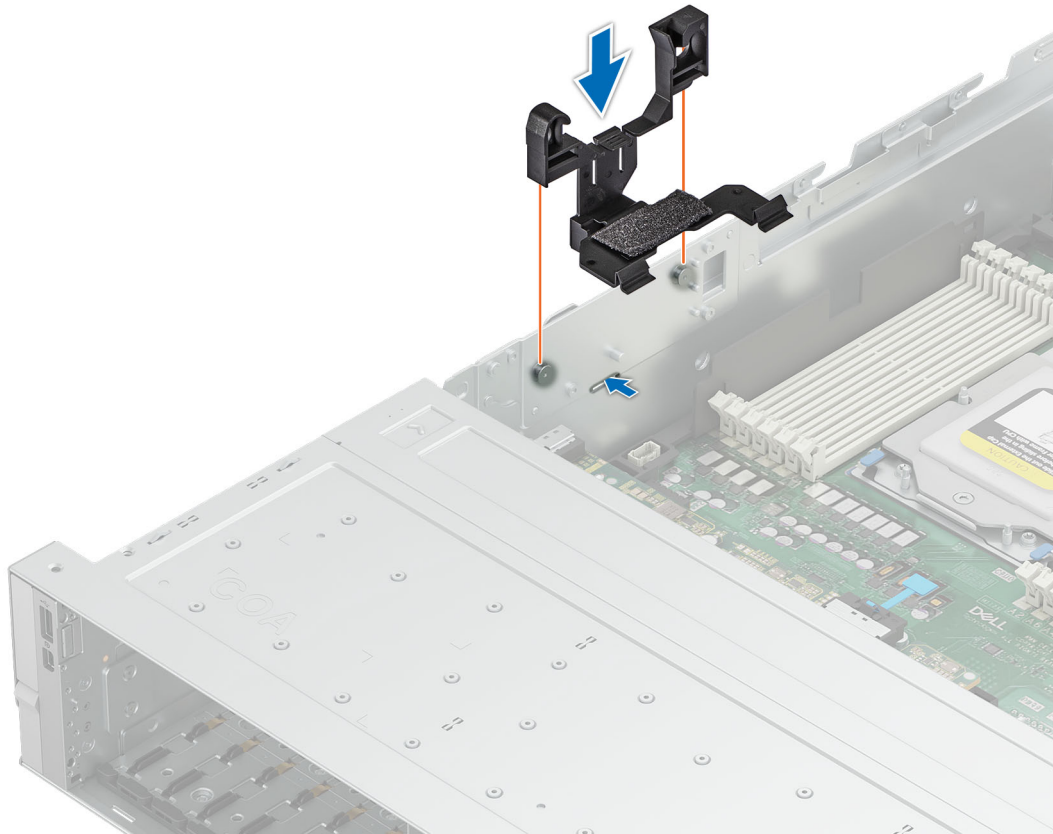

Figure 68. Installing the right side wall bracket

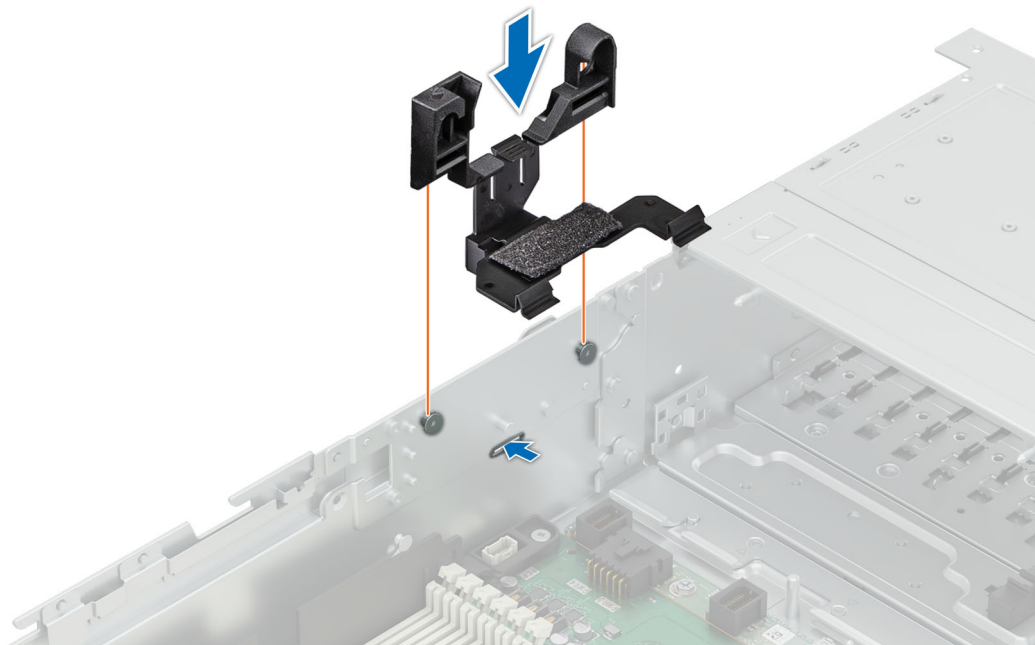

Figure 69. Installing the right side wall bracket

Next steps

1. Install the cooling fan cage assembly.
2. If removed, install the air shroud.

3. If removed, [install the drive backplane cover](#).
4. Follow the procedure listed in the [After working inside your system](#).

PERC module

Removing the front mounting front PERC module

Prerequisites

1. Follow the safety guidelines listed in the [Safety instructions](#).
2. Follow the procedure listed in the [Before working inside your system](#).
3. If installed, [remove the air shroud](#).
4. [Remove the drive backplane cover](#).
5. Observe and disconnect the drive backplane cables from the connector on the HPM board and backplane.

NOTE: See [cable routing](#) section for more information.

Steps

1. Using a Phillips #2 screwdriver, loosen the captive screws on the front PERC module.
2. Slide and pull the front PERC module to disengage from the connector on the drive backplane.

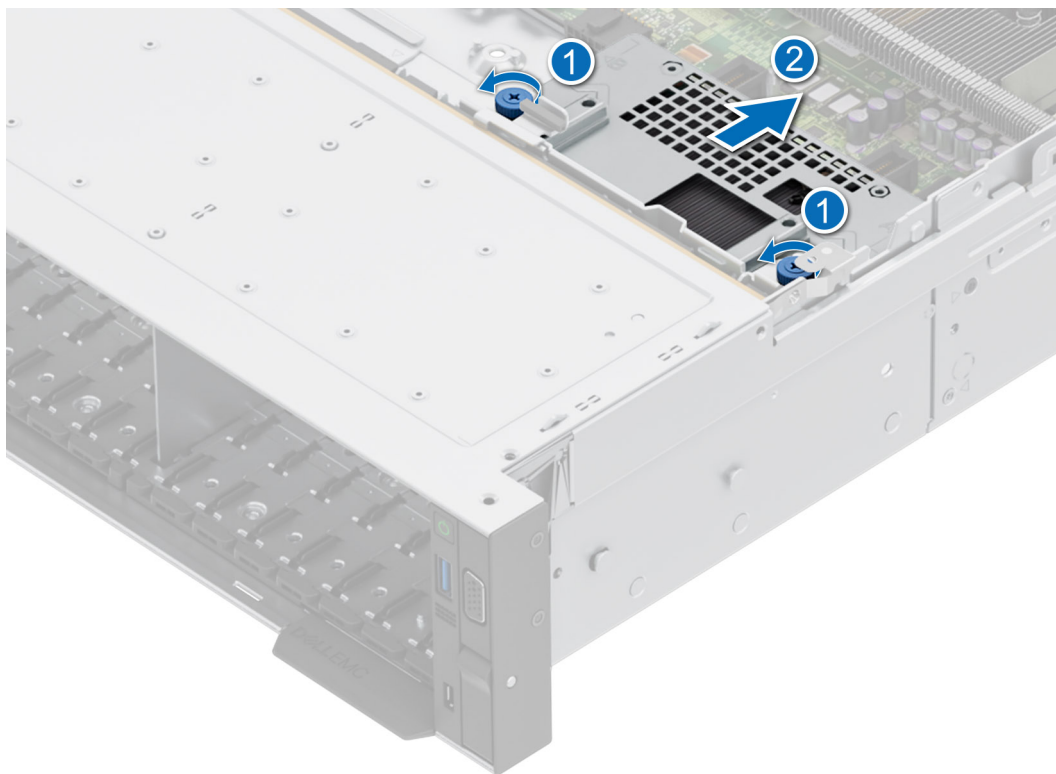

Figure 70. Removing the front mounting front PERC module

Next steps

1. [Replace the front mounting front PERC module](#).

Installing the front mounting front PERC module

Prerequisites

1. Follow the safety guidelines listed in the [Safety instructions](#).
2. Follow the procedure listed in [Before working inside your system](#).
3. [Remove the backplane cover](#).
4. If installed, [remove the air shroud](#).
5. Route the cable properly to prevent the cable from being pinched or crimped.

Steps

1. Align the front PERC module at an angle until the tray touches the slot in the system.
2. Slide and press the front PERC module connector with the connector on the drive backplane until firmly seated.
3. Using a Phillips #2 screwdriver, tighten the captive screws on the front PERC module.

 **NOTE:** The numbers on the image do not depict the exact steps. The numbers are for representation of sequence.

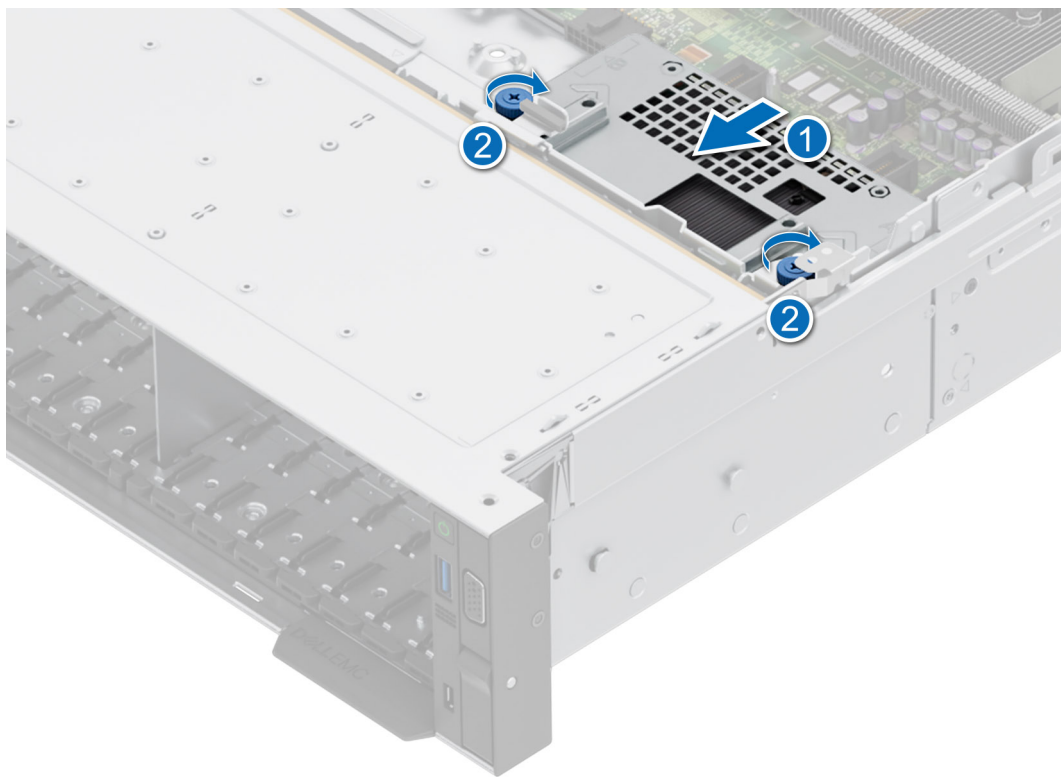



Figure 71. Installing the front mounting front PERC module

Next steps

1. Observe and connect the drive backplane cables from the connector on the HPM board and backplane.

 **NOTE:** See [cable routing](#) section for more information.

2. Reconnect all the required cables.
3. [Install the drive backplane cover](#).
4. [Install the air shroud](#).
5. Follow the procedure listed in [After working inside your system](#).

Removing the PERC H975i module

Prerequisites

1. Follow the safety guidelines listed in the [Safety instructions](#).
2. Follow the procedure listed in the [Before working inside your system](#).
3. If installed, [remove the air shroud](#).
4. [Remove the drive backplane cover](#).
5. Observe and disconnect the drive backplane cables from the connector on the HPM board and backplane.

NOTE: See [cable routing](#) section for more information.

Steps

1. Press the release latches in the direction of the arrows that are marked on the PERC tray and lift the tray out from the system.

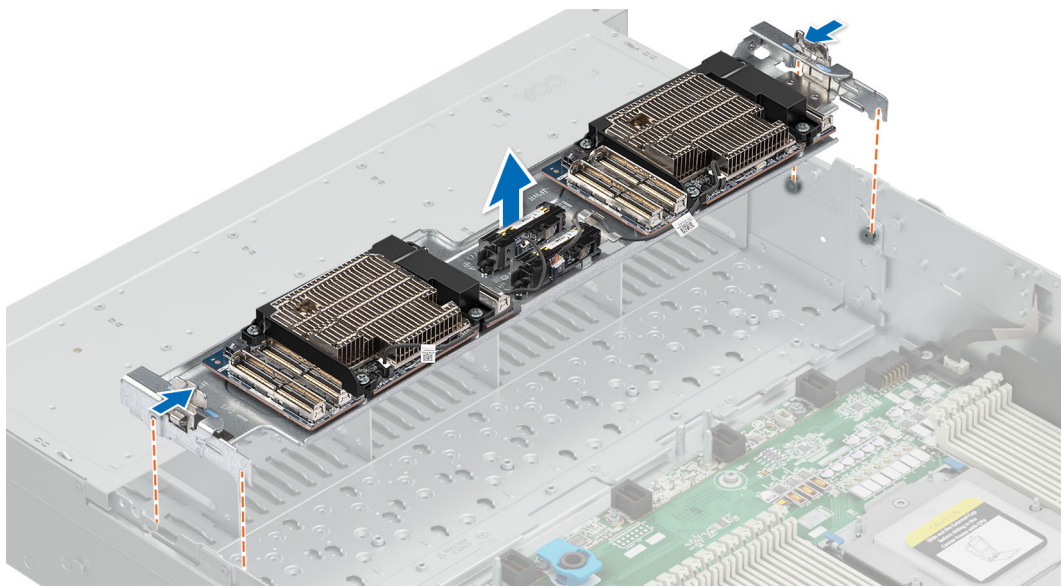

Figure 72. Removing the PERC H975i module

2. Disconnect the battery cables from the PERC H975i and unroute it from the cable holders and remove them.

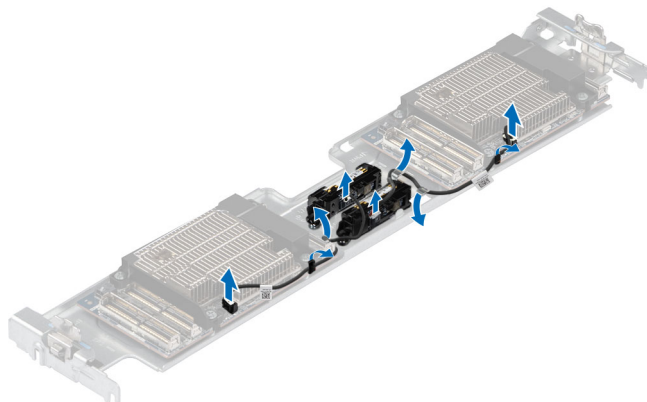

Figure 73. Removing the battery cables

3. Using a Phillips 2 screwdriver, loosen the screws and remove the H975i from the tray, and the shroud from the H975i.
4. Using a Phillips 2 screwdriver, loosen a screw and remove the battery holder from the tray.

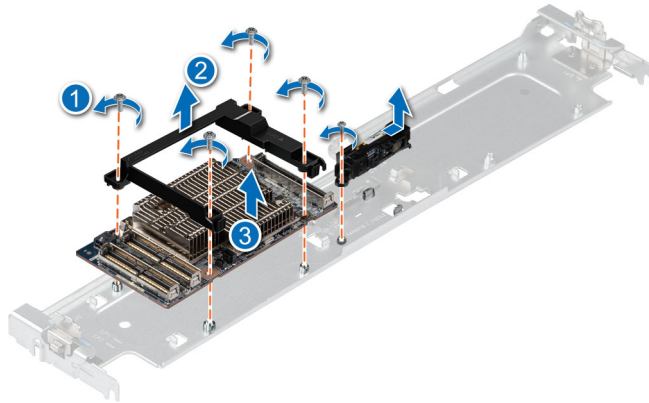

Figure 74. Removing the PERC H975i, shroud, and battery holder

Next steps

1. [Replace the front mounting front PERC module.](#)

Installing the PERC H975i module

Prerequisites

1. Follow the safety guidelines listed in the [Safety instructions](#).
2. Follow the procedure listed in [Before working inside your system](#).
3. [Remove the backplane cover](#).
4. If installed, [remove the air shroud](#).
5. Route the cable properly to prevent the cable from being pinched or crimped.

Steps

1. Align the H975i and the shroud with the screw-guide pins on the PERC tray. Using a Phillips 2 screwdriver, tighten the screws to secure them in place.
2. Push the battery holder into the lock mark on the PERC tray. Using a Phillips 2 screwdriver, tighten the captive screw to secure the battery holder to the PERC tray .

NOTE: The numbers on the image do not depict the exact steps. The numbers are for representation of sequence.

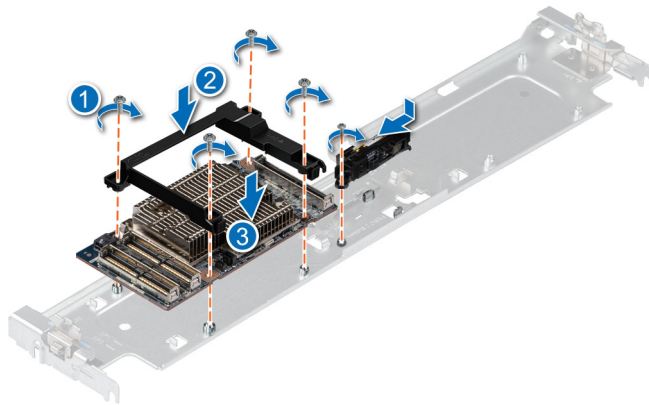

Figure 75. Installing the PERC H975i, shroud and battery holder

3. Route the battery cable correctly into the cable holders. Connect the battery cable to the PERC H975i.

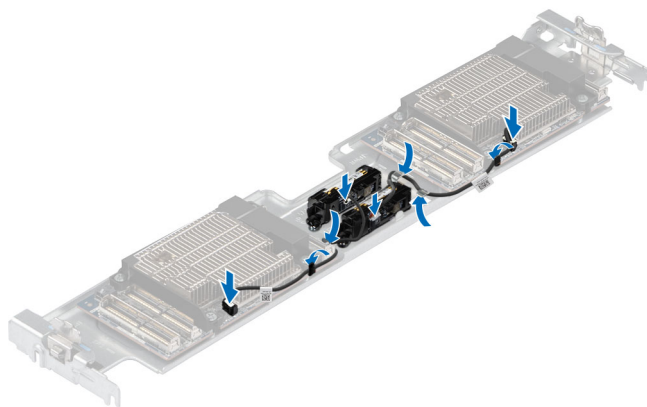

Figure 76. Routing the battery cables

4. Align the PERC tray with the guide slots on the chassis.
5. Lower the PERC tray towards the chassis and press down on both sides of the tray to ensure both the T-pin and latch locks in place.

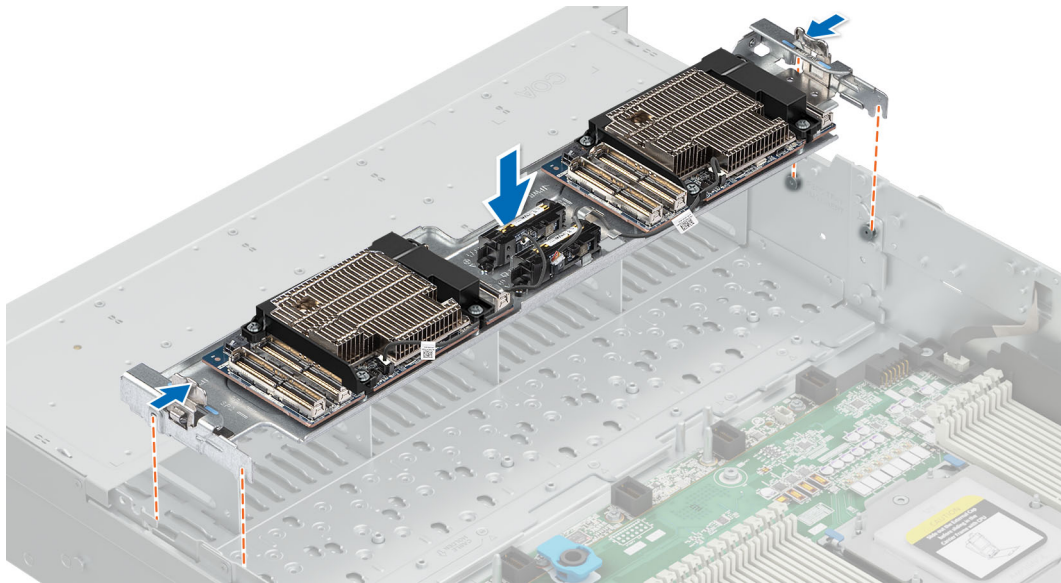

Figure 77. Installing the PERC H975i module

Next steps

1. Observe and connect the drive backplane cables from the connector on the HPM board and backplane.

i **NOTE:** See [cable routing](#) section for more information.

2. Reconnect all the required cables.
3. [Install the drive backplane cover.](#)
4. [Install the air shroud.](#)
5. Follow the procedure listed in [After working inside your system.](#)

Cable routings

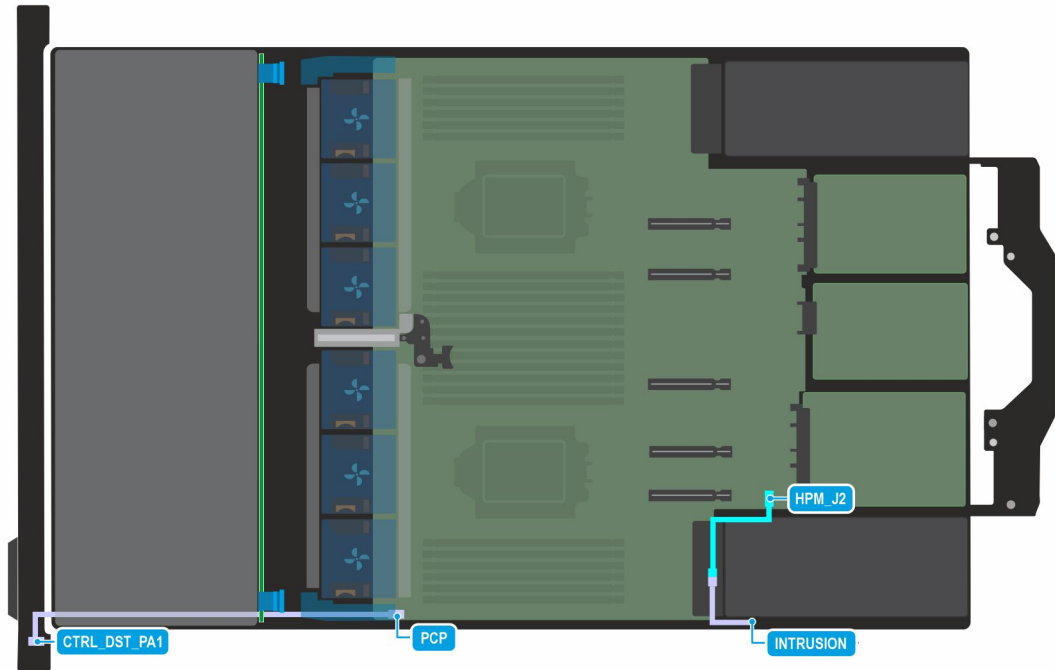

Figure 78. C0: No backplane configuration

Table 56. No backplane configuration

Order	From	To
1	HPM_J2 (power connector on HPM board)	INTRUSION (intrusion switch connector)
2	CTRL_DST_PA1 (right control panel)	PCP (system board)

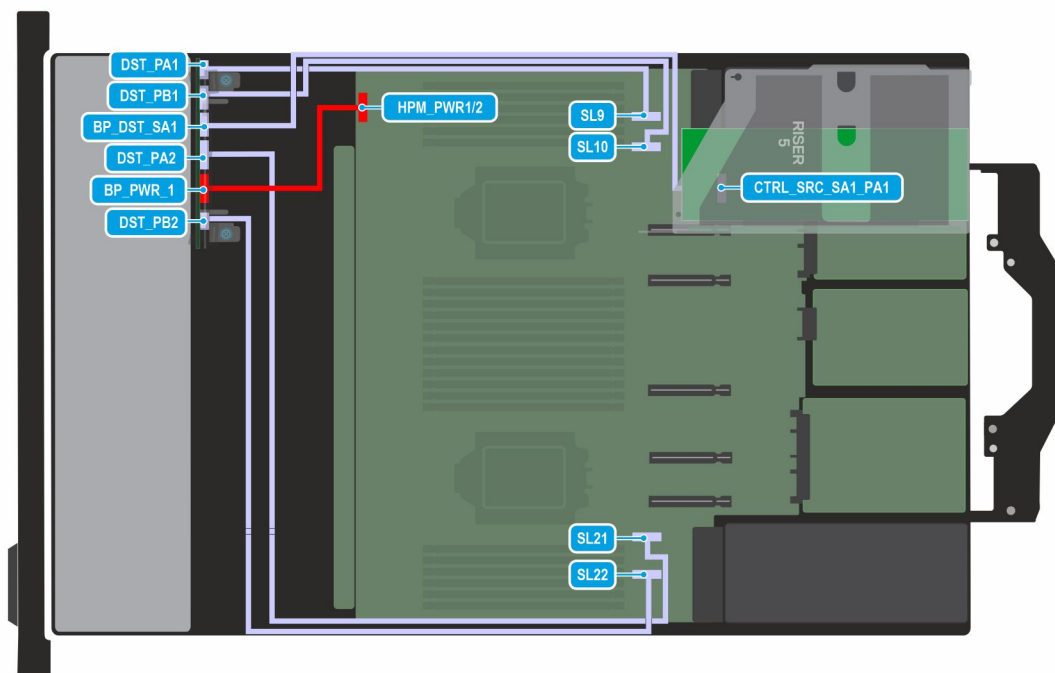

Figure 79. C4-2: 8 x 2.5-inch Universal drives

Table 57. C4-2: 8 x 2.5-inch Universal drives

Order	From	To
1	HPM_PWR1/2 (power connector on HPM board)	BP_PWR_1 (backplane power connector)
2	SL9/SL10 (signal connector on HPM board)	DST_PA1/PB1 (backplane signal connector)
3	SL21/22 (signal connector on HPM board)	DST_PA1/PA2 (backplane signal connector)
4	CTRL_SRC_SA1_PA1 (adapter PERC)	BP_DST_SA1 (backplane signal connector)

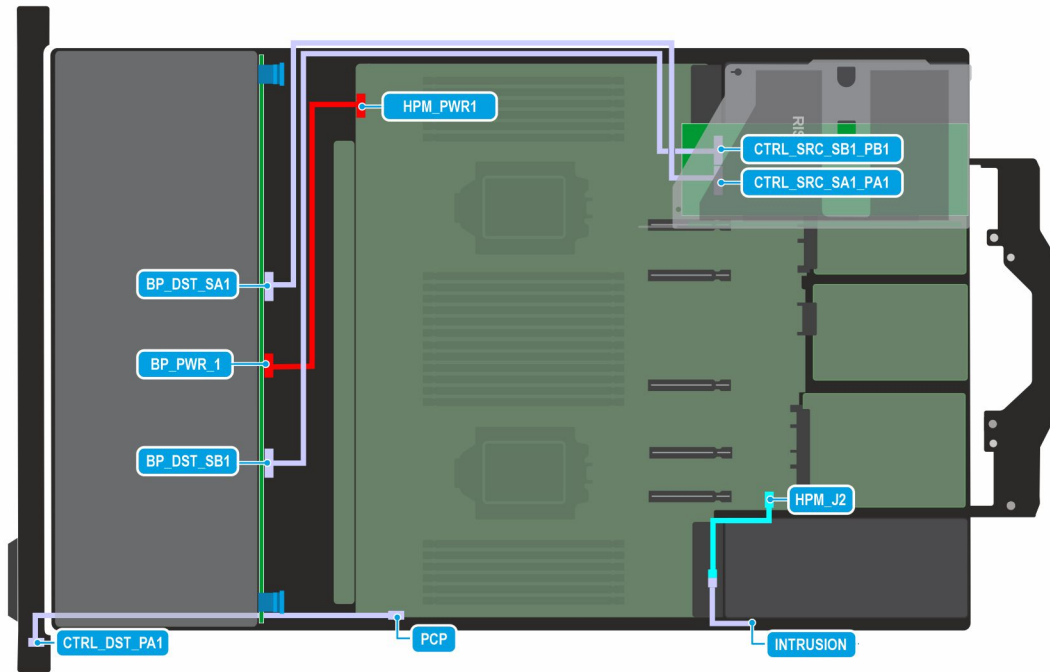

Figure 80. C1-2: 12 x 3.5 SAS/SATA

Table 58. C1-2: 12 x 3.5 SAS/SATA

Order	From	To
1	HPM_PWR1 (power connector on HPM board)	BP_PWR_1 (backplane power connector)
2	HPM_J2 (power connector on HPM board)	INTRUSION (intrusion switch connector)
3	CTRL_SRC_SB1_PB1 (adapter PERC)	BP_DST_SB1 (backplane signal connector)
4	CTRL_SRC_SA1_PA1 (adapter PERC)	BP_DST_SA1 (backplane signal connector)
5	CTRL_DST_PA1 (right control panel)	PCP (system board)

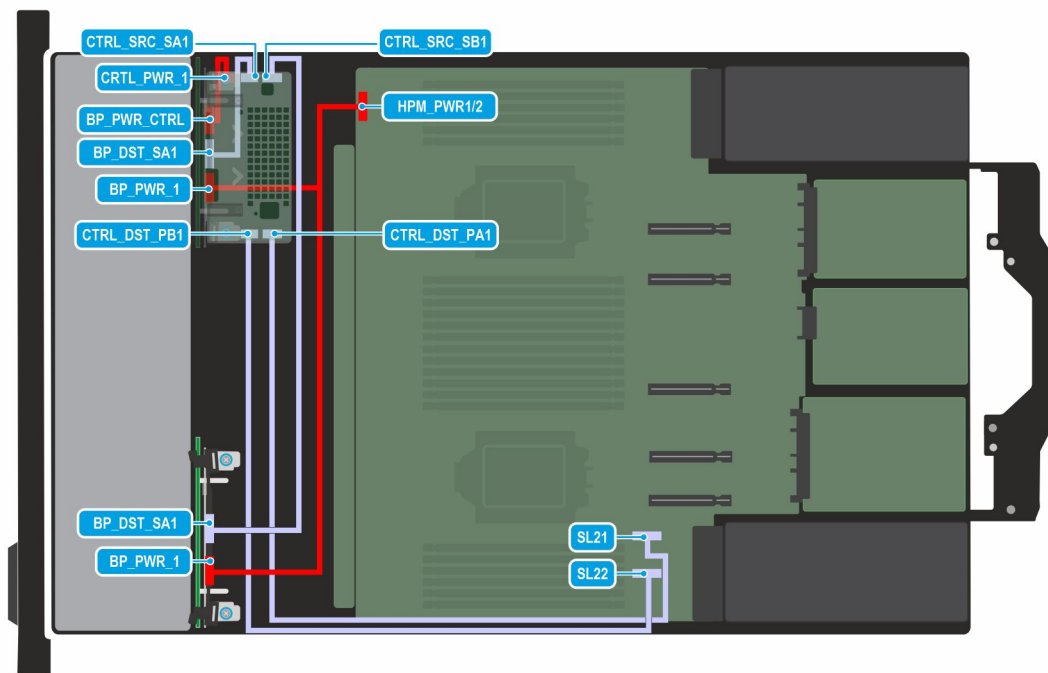

Figure 81. C2-1: 16 x 2.5-inch SAS/SATA drives

Table 59. C2-1: 16 x 2.5-inch SAS/SATA drives

Order	From	To
1	HPM_PWR1/2 (power connector on HPM board)	BP_PWR_1 (backplane power connector)
2	CTRL_SRC_SB1 (adapter PERC)	BP_DST_SA1 (backplane signal connector)
3	CTRL_SRC_SA1(adapter PERC)	BP_DST_SA1 (backplane signal connector)
4	SL21/22 (signal connector on HPM board)	CTRL_DST_PA1/PA2 (adapter PERC)
5	CTRL_PWR_1 (adapter PERC power connector)	BP_PWR_CTRL (backplane power connector)

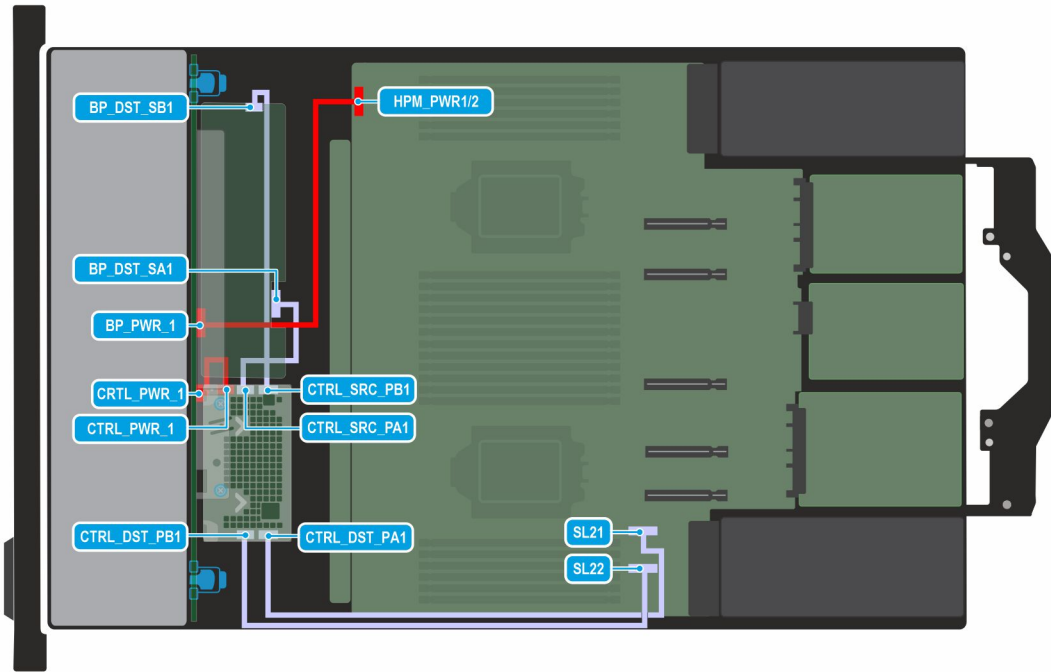

Figure 82. C3-1: 24 x 2.5-inch SAS/SATA

Table 60. C3-1: 24 x 2.5-inch SAS/SATA

Order	From	To
1	HPM_PWR1/2 (power connector on HPM board)	BP_PWR_1 (backplane power connector)
2	CTRL_SRC_SB1 (adapter PERC)	BP_DST_SB1 (backplane signal connector)
3	CTRL_SRC_SA1(adapter PERC)	BP_DST_SA1 (backplane signal connector)
4	SL21/22 (signal connector on HPM board)	CTRL_DST_PA1/PB2 (adapter PERC)

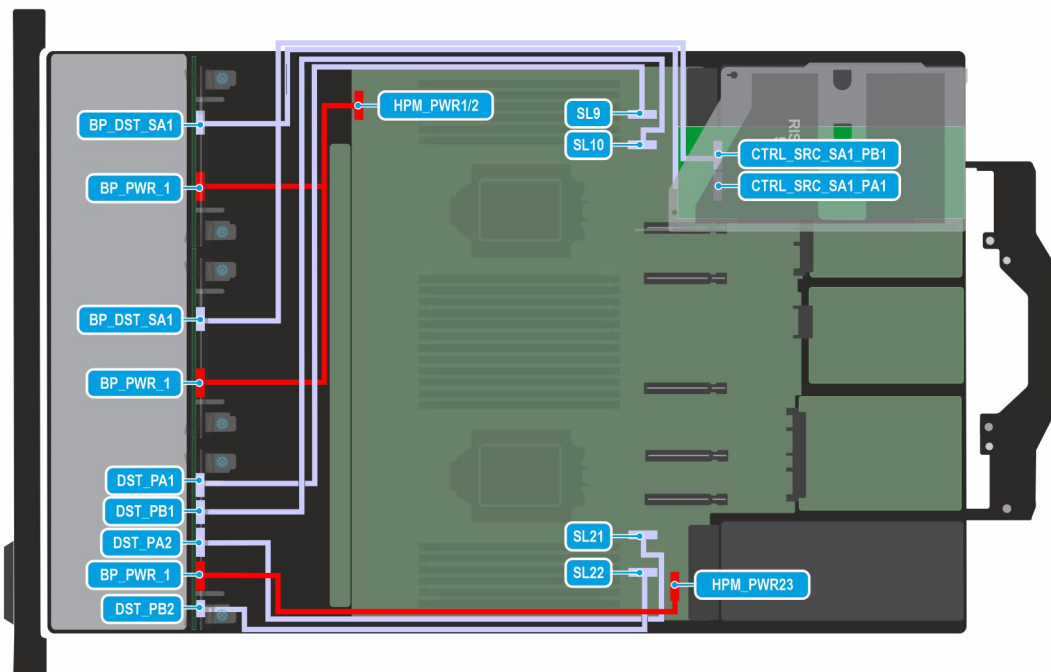

Figure 83. C5-1: 16 x 2.5-inch SAS/SATA + 8 x 2.5-inch U.2 NVMe

NOTE: Follow the sequential order as shown in the table to remove the cables, to install the cables follow the reverse sequential order.

Table 61. C5-1: 16 x 2.5-inch SAS/SATA + 8 x 2.5-inch U.2 NVMe

Order	From	To
1	HPM_PWR1/2 (power connector on HPM board)	BP_PWR_1 (backplane power connector)
2	HPM_PWR23 (power connector on HPM board)	BP_PWR_1 (backplane power connector)
3	SL9/SL10 (signal connector on HPM board)	DST_PA1/PB1 (backplane signal connector)
4	SL21 (signal connector on HPM board)	DST_PA2 (backplane signal connector)
5	SL22 (signal connector on HPM board)	DST_PB2 (backplane signal connector)
6	CTRL_SRC_SB1_PA1 (adapter PERC)	BP_DST_SA1 (backplane signal connector)
7	CTRL_SRC_SB1_PB1 (adapter PERC)	BP_PA2 (backplane signal connector)

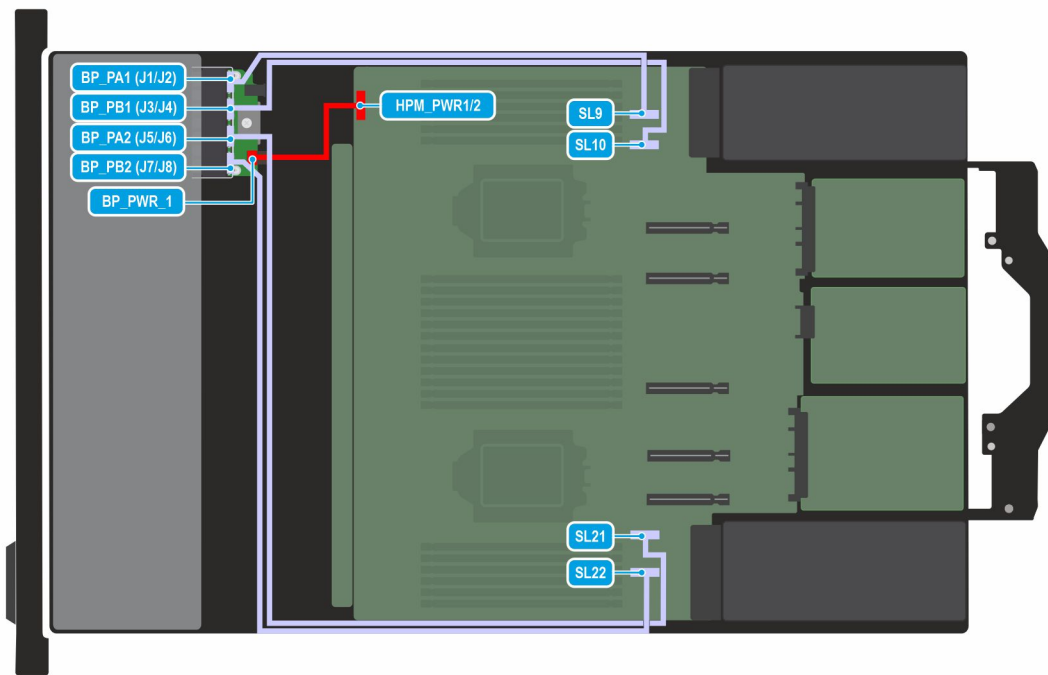

Figure 84. C6-1: 8 x EDSFF E3.S Gen5 NVMe

NOTE: Follow the sequential order as shown in the table to remove the cables, to install the cables follow the reverse sequential order.

Table 62. C6-1: 8 x EDSFF E3.S Gen5 NVMe

Order	From	To
1	HPM_PWR23 (power connector on HPM board)	BP_PWR_1 (backplane power connector)
2	SL9 (signal connector on HPM board)	BP_PA1 (backplane signal connector)
3	SL10 (signal connector on HPM board)	BP_PB1 (backplane signal connector)
4	SL21 (signal connector on HPM board)	BP_PA2 (backplane signal connector)
5	SL22 (signal connector on HPM board)	BP_PB2 (backplane signal connector)

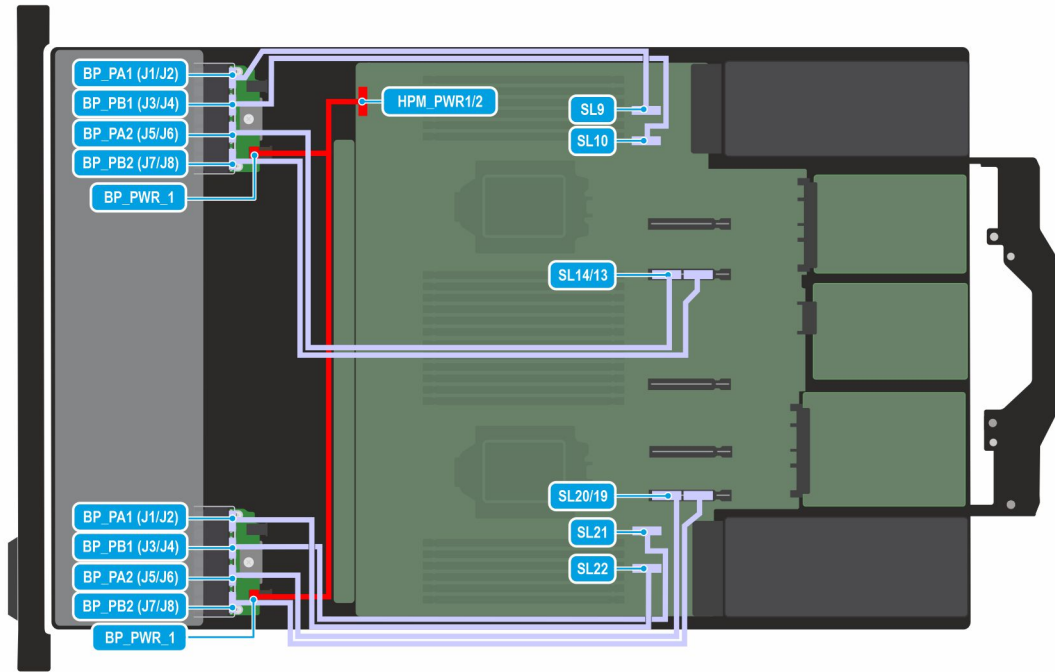

Figure 85. C7-1: 16 x EDSFF E3.S Gen5 NVMe

NOTE: Follow the sequential order as shown in the table to remove the cables, to install the cables follow the reverse sequential order.

Table 63. C7-1: 16 x EDSFF E3.S Gen5 NVMe

Order	From	To
1	HPM_PWR1/2 (power connector on HPM board)	BP_PWR_1 (backplane power connector)
2	SL9 (signal connector on HPM board)	BP_PA1 (backplane signal connector)
3	SL10 (signal connector on HPM board)	BP_PB1 (backplane signal connector)
4	SL14/13 (signal connector on HPM board)	BP_PA2/PB2 (backplane signal connector)
5	SL21 (signal connector on HPM board)	BP_PA1 (backplane signal connector)
6	SL22 (signal connector on HPM board)	BP_PB1 (backplane signal connector)
7	SL20/19 (signal connector on HPM board)	BP_PA2/PB2 (backplane signal connector)

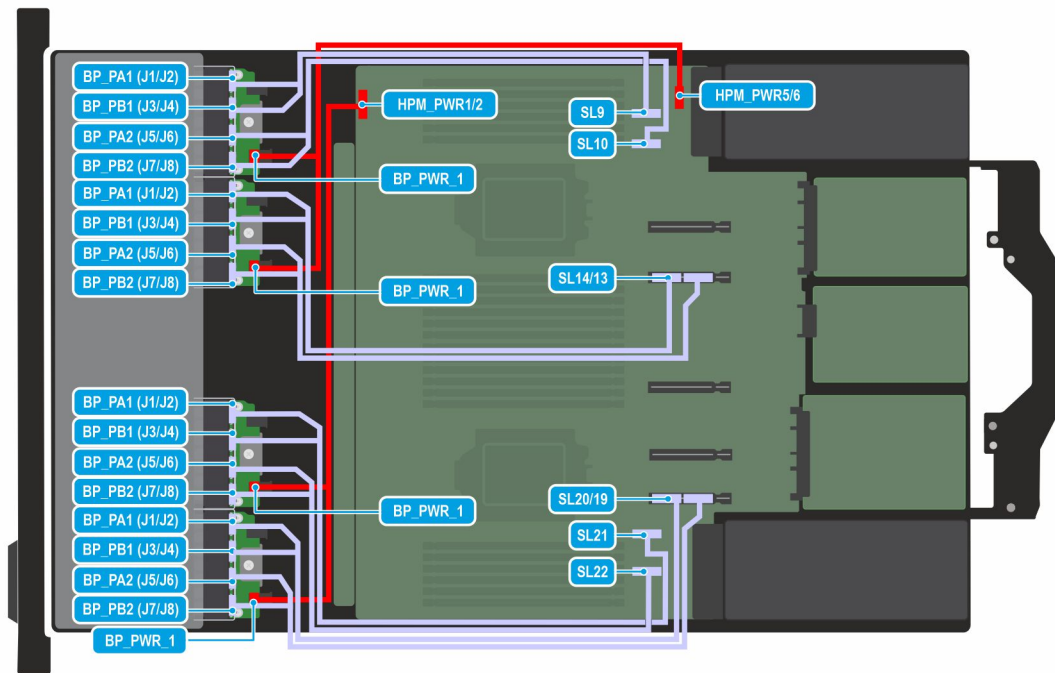

Figure 86. C8-1: 32 x EDSFF E3.S Gen5 NVMe

Table 64. C8-1: 32 x EDSFF E3.S Gen5 NVMe

Order	From	To
1	HPM_PWR1/2 (power connector on HPM board)	BP_PWR_1 (backplane power connector)
2	HPM_PWR5/6 (power connector on HPM board)	BP_PWR_1 (backplane power connector)
3	SL9 (signal connector on HPM board)	BP_PA1(J1/J2)/PB1(J3/J4) (backplane signal connector)
4	SL10 (signal connector on HPM board)	BP_PA2(J5/J6)/PB2(J7/J8) (backplane signal connector)
5	SL14/13 (signal connector on HPM board)	BP_PA1(J1/J2)/PB1(J3/J4) (backplane signal connector) BP_PA2(J5/J6)/PB2(J7/J8) (backplane signal connector)
6	SL21 (signal connector on HPM board)	BP_PA1(J1/J2)/PB1(J3/J4) (backplane signal connector)
7	SL22 (signal connector on HPM board)	BP_PA2(J5/J6)/PB2(J7/J8) (backplane signal connector)
8	SL20/19 (signal connector on HPM board)	BP_PA1(J1/J2)/PB1(J3/J4) (backplane signal connector) BP_PA2(J5/J6)/PB2(J7/J8) (backplane signal connector)

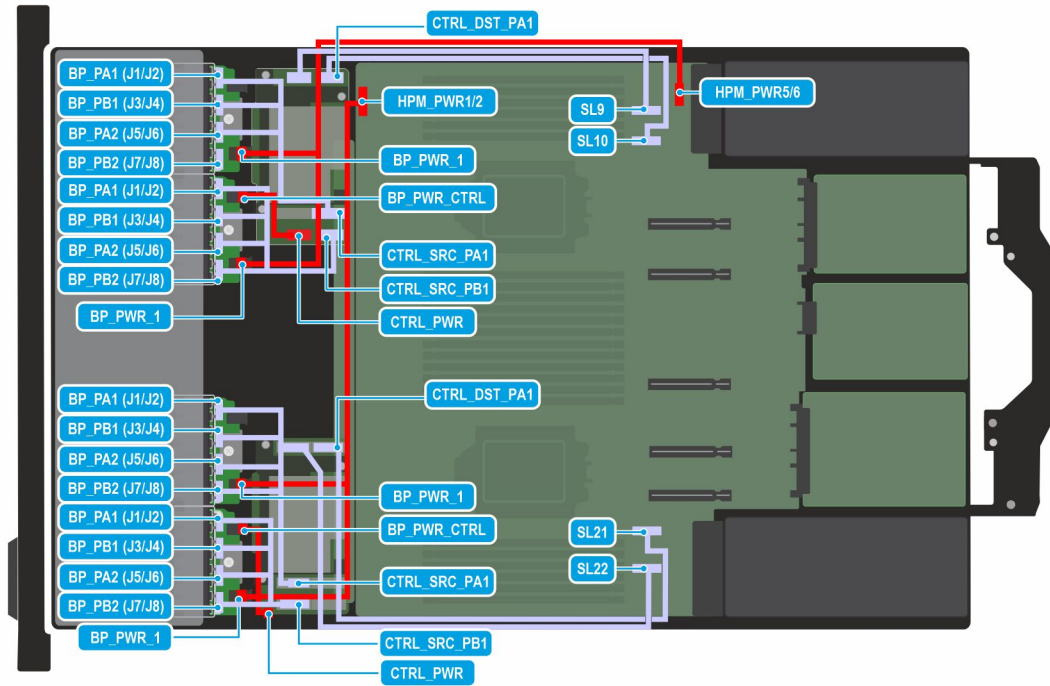

Figure 87. C8-3: 32 x EDSFF E3.S Gen5 NVMe with dual PERC H975i

Table 65. C8-3: 32 x EDSFF E3.S Gen5 NVMe with dual PERC H975i

Order	From	To
1	HPM_PWR1/2 (power connector on HPM board)	BP_PWR_1 (backplane power connector)
2	HPM_PWR5/6 (power connector on HPM board)	BP_PWR_1 (backplane power connector)
3	SL9 (signal connector on HPM board)	BP_PA1(J1/J2)/PB1(J3/J4) (backplane signal connector)
4	SL10 (signal connector on HPM board)	BP_PA2(J5/J6)/PB2(J7/J8) (backplane signal connector)
5	SL14/13 (signal connector on HPM board)	BP_PA1(J1/J2)/PB1(J3/J4) (backplane signal connector) BP_PA2(J5/J6)/PB2(J7/J8) (backplane signal connector)
6	SL21 (signal connector on HPM board)	BP_PA1(J1/J2)/PB1(J3/J4) (backplane signal connector)
7	SL22 (signal connector on HPM board)	BP_PA2(J5/J6)/PB2(J7/J8) (backplane signal connector)
8	SL20/19 (signal connector on HPM board)	BP_PA1(J1/J2)/PB1(J3/J4) (backplane signal connector) BP_PA2(J5/J6)/PB2(J7/J8) (backplane signal connector)
9	CTRL_PWR (PERC power connector)	BP_PWR_CTRL (backplane power connector to controller)
10	CTRL_SRC_PB1 (PERC signal connector)	BP_PA1 (J1/J2), BP_PB1 (J3/J4), BP_PA2 (J5/J6), BP_PB2 (J7/J8) (backplane signal connectors)

Table 65. C8-3: 32 x EDSFF E3.S Gen5 NVMe with dual PERC H975i (continued)

Order	From	To
11	CTRL_SRC_PA1 (PERC signal connector)	BP_PA1 (J1/J2), BP_PB1 (J3/J4), BP_PA2 (J5/J6), BP_PB2 (J7/J8) (backplane signal connectors)
12	CTRL_DST_PA1 (PERC signal connector to HPM board)	SL_21 (signal connector on HPM board)
13	CTRL_PWR (PERC power connector)	BP_PWR_CTRL (backplane power connector to controller)
14	CTRL_SRC_PB1 (PERC signal connector)	BP_PA1 (J1/J2), BP_PB1 (J3/J4), BP_PA2 (J5/J6), BP_PB2 (J7/J8) (backplane signal connectors)
15	CTRL_SRC_PA1 (PERC signal connector)	BP_PA1 (J1/J2), BP_PB1 (J3/J4), BP_PA2 (J5/J6), BP_PB2 (J7/J8) (backplane signal connectors)
16	CTRL_DST_PA1 (PERC signal connector to HPM board)	SL_21 (signal connector on HPM board)

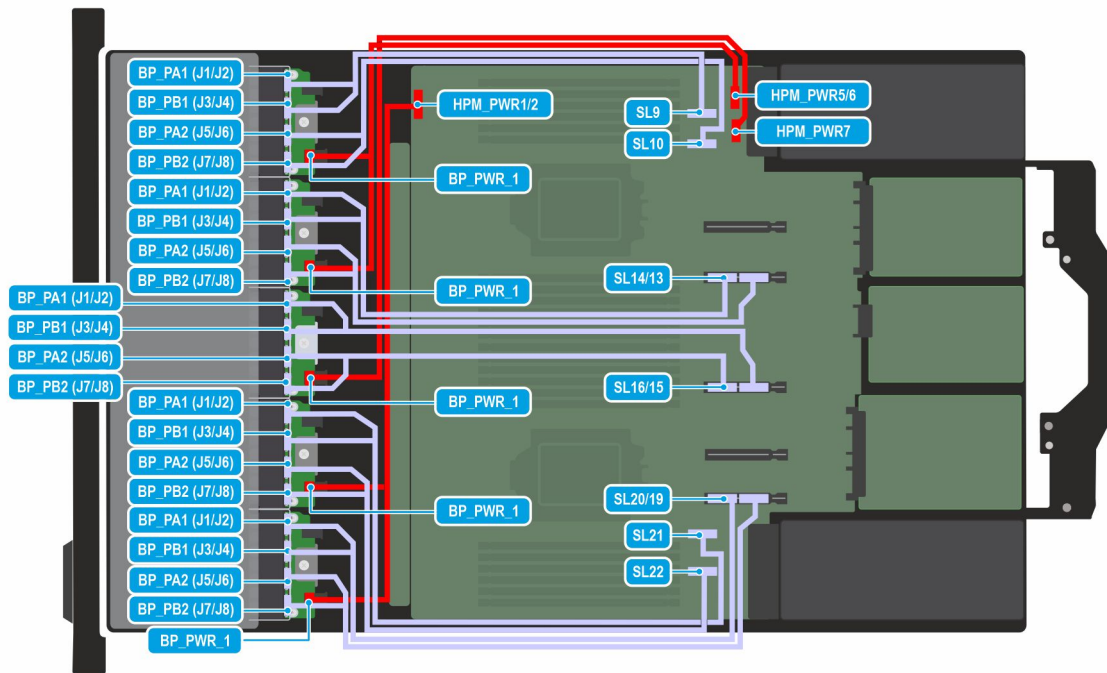

Figure 88. C9-1: 40 x EDSFF E3.S Gen5 NVMe

Table 66. C9-1: 40 x EDSFF E3.S Gen5 NVMe

Order	From	To
1	HPM_PWR1/2 (power connector on HPM board)	BP_PWR_1 (backplane power connector)
2	HPM_PWR5/6 (power connector on HPM board)	BP_PWR_1 (backplane power connector)
3	HPM_PWR7/8 (power connector on HPM board)	BP_PWR_1 (backplane power connector)
4	SL9 (signal connector on HPM board)	BP_PA1(J1/J2)/PB1(J3/J4) (backplane signal connector)
5	SL10 (signal connector on HPM board)	BP_PA2(J5/J6)/PB2(J7/J8) (backplane signal connector)

Table 66. C9-1: 40 x EDSFF E3.S Gen5 NVMe (continued)

Order	From	To
6	SL14/13 (signal connector on HPM board)	BP_PA1(J1/J2)/PB1(J3/J4) (backplane signal connector)
7	SL16/15 (signal connector on HPM board)	BP_PA2(J5/J6)/PB2(J7/J8) (backplane signal connector)
8	SL21 (signal connector on HPM board)	BP_PA1(J1/J2)/PB1(J3/J4) (backplane signal connector)
9	SL22 (signal connector on HPM board)	BP_PA2(J5/J6)/PB2(J7/J8) (backplane signal connector)
10	SL20/19 (signal connector on HPM board)	BP_PA1(J1/J2)/PB1(J3/J4) (backplane signal connector)

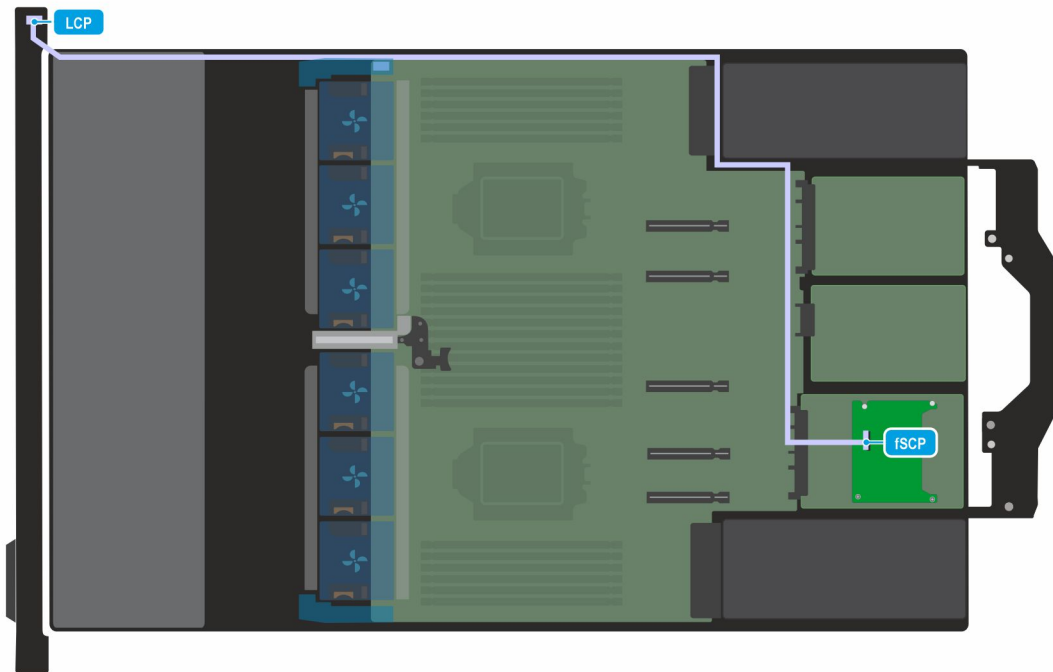

Figure 89. Attic board to the Left Control Panel (LCP) - Secondary

Table 67. Attic board to the Left Control Panel (LCP) - Secondary

Order	From	To
1	LCP (Left Control Panel (LCP) - Secondary)	fSCP (Attic board)

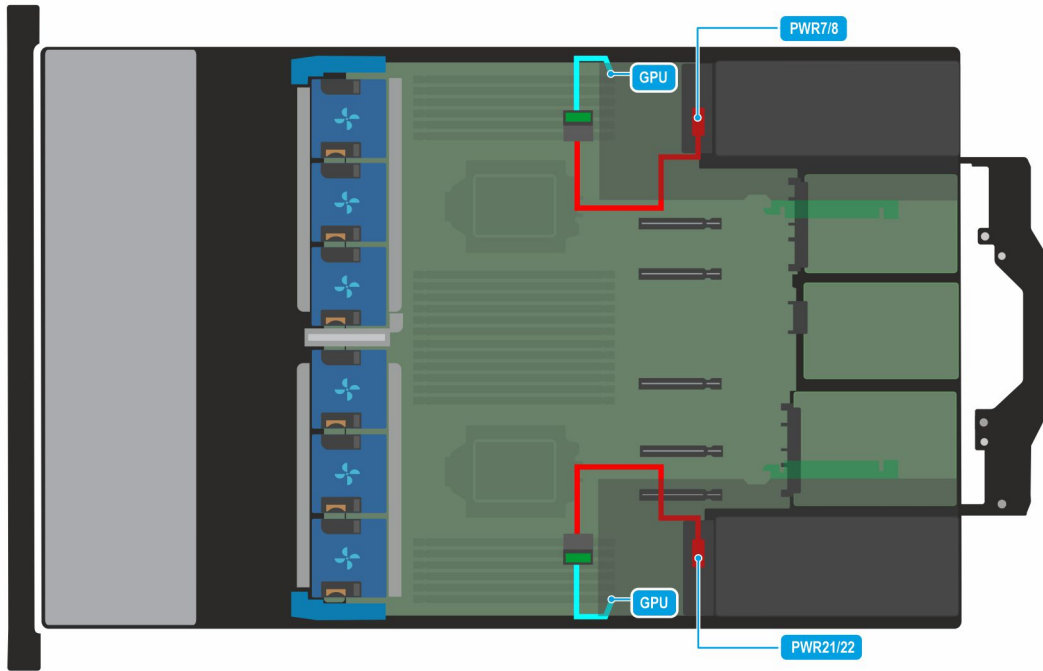

Figure 90. Dual-width GPU cable connections

Table 68. Dual-width GPU cable connections

Order	From	To
1	HPM board power connector	GPU_R1
2	HPM board power connector	GPU_R5

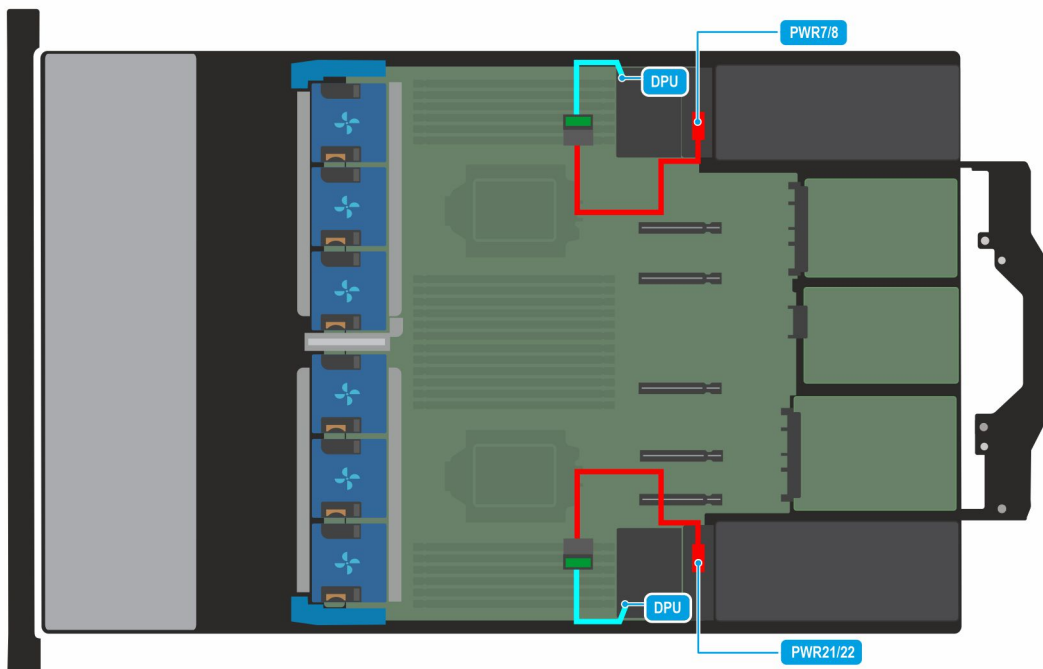

Figure 91. DPU cable connections

Table 69. DPU cable connections

Order	From	To
1	PWR 7/8 (HPM board power connector)	DPU
2	PWR 21/22 (HPM board power connector)	DPU

System memory

System memory guidelines

The PowerEdge R7725 system supports DDR5 registered DIMMs (RDIMMs). System memory holds the instructions that are started by the processor.

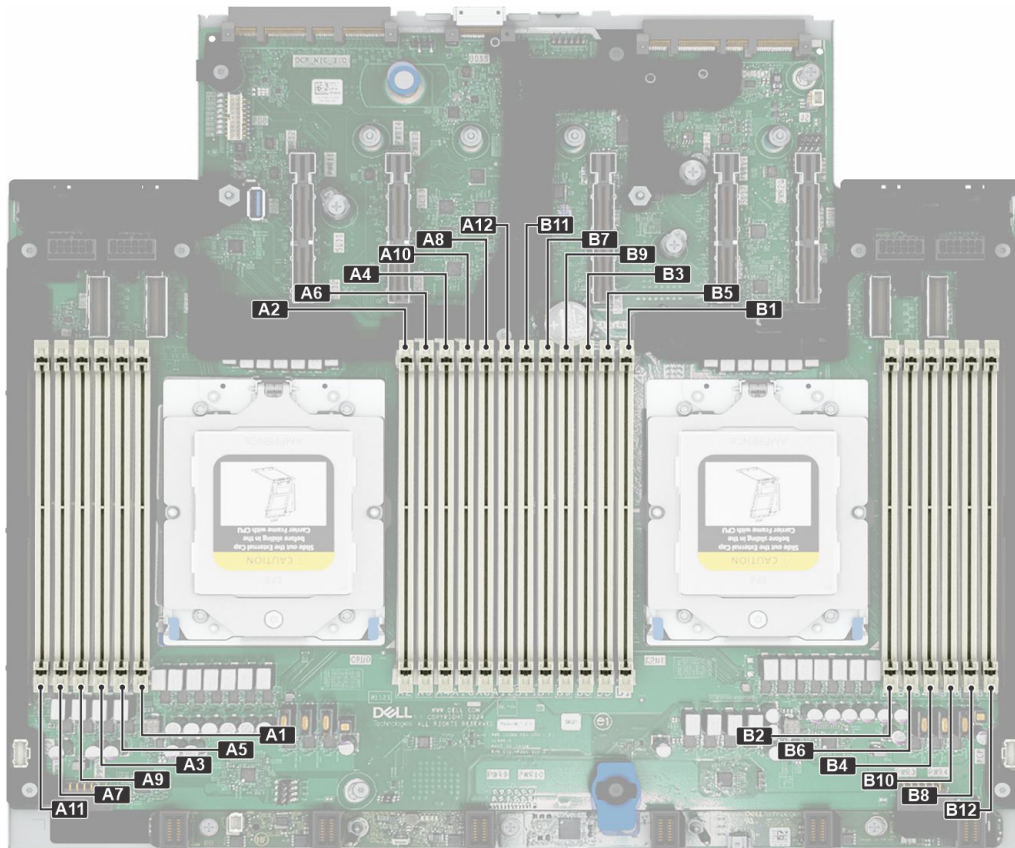

Figure 92. Memory channels

Memory channels are organized as follows:

Table 70. Memory channels A through F

Processor	Channel A	Channel B	Channel C	Channel D	Channel E	Channel F
Processor 0	Slots A1	Slots A5	Slots A3	Slots A9	Slots A7	Slots A11
Processor 1	Slots B1	Slots B5	Slots B3	Slots B9	Slots B7	Slots B11

Table 71. Memory channels G through L

Processor	Channel G	Channel H	Channel I	Channel J	Channel K	Channel L
Processor 0	Slots A2	Slots A6	Slots A4	Slots A10	Slots A8	Slots A12
Processor 1	Slots B2	Slots B6	Slots B4	Slots B10	Slots B8	Slots B12

Table 72. Supported memory matrix

DIMM type	Rank	Capacity	DIMM rated voltage and speed	Operating Speed
				1 DIMM per channel (DPC)
RDIMM	1 R	16 GB	DDR5 (1.1 V), 6400 MT/s	6400 MT/s
RDIMM	2 R	32 GB, 64 GB, 96 GB, 128 GB	DDR5 (1.1 V), 6400 MT/s	6400 MT/s
RDIMM	8 R	256 GB	DDR5 (1.1 V), 6400 MT/s	6400 MT/s

Table 73. Memory Capacity Requirement For Supported GPU Cards

Recommended System Memory Range (1.5x - 2x GPU Memory)							
GPU Name	GPU Memory	x1 GPU	x2 GPUs	x3 GPUs	x4 GPUs	x5 GPUs	x6 GPUs
L4	24 GB	36-48 GB	72-96 GB	108-144 GB	144-192 GB	180-240 GB	144-288 GB
L40S	48 GB	72-96 GB	144-192 GB	N/A	N/A	N/A	N/A
A16	64 GB	96-128 GB	196-256 GB	N/A	N/A	N/A	N/A
H100NVL	94 GB	141-188 GB	282-376 GB	N/A	N/A	N/A	N/A
RTX Pro 6000 BSE	96 GB	144-192 GB	288-384 GB	N/A	N/A	N/A	N/A
H200NVL	141 GB	212-282 GB	423-564 GB	N/A	N/A	N/A	N/A

NOTE: The processor may reduce the performance of the rated DIMM speed.

NOTE: Maximum DIMM transfer speed support dependent on CPU SKU and DIMM population.

Memory interleaving with Non-uniform memory access (NUMA)

Non-uniform memory access (NUMA) is a memory design used in multi-processing, where the memory access time depends on the memory location relative to the processor. In NUMA, a processor can access its own local memory faster than the non-local memory.

NUMA nodes per socket (NPS) is a new feature added that allows you to configure the memory NUMA domains per socket. The configuration can consist of one whole domain (NPS1), two domains (NPS2), or four domains (NPS4). In the case of a two-socket platform, an additional NPS profile is available to have whole system memory to be mapped as single NUMA domain (NPS0). For more information on the memory interleaving for NPSx, see the Memory interleaving population rules section in this topic.

BIOS implementation for NPSx

- The BIOS Setup menu presents the applicable NPSx options based on the underlying model number. A change to the current NPSx is communicated to pre-BIOS firmware to take effect on the next boot. The default NPS setting is 1.
- During boot, if the selected NPSx option is not allowed for the model number (for example, if the processor model number changes between reboot), system will halt at the end of POST with UEFI0388 message displayed. On the next reboot, the system will fall back to NPS1 default setting.
- During boot, if the preferred interleaving for the current NPSx is not possible due to memory configuration (for example, the memory population is inconsistent with the preferred interleaving), BIOS shows a warning message UEFI0391.

Table 74. NPS option and Memory Interleave

NPS Option	CCD Configuration	Memory Interleaving	Server Package (12 memory channels)
NPS4: Four NUMA nodes per socket, one node per quadrant.	Symmetric configuration across all quadrants of the SoC.	Firmware will attempt to interleave all memory channels on each Quadrant of the SoC.	3- way interleave per node: {ABD}, {CEF}, {GHK}, and {IKL}
NPS2: Two NUMA nodes per socket, one node per left/right half of the SoC.	Requires symmetrical CCD configuration across left/right halves of the SoC.	Firmware will attempt to interleave all memory channels on each Half of the SoC.	6-way Interleave per Node: {ABCDEF} and {GHIJKL}
NPS1: One NUMA node per socket.	Available for any CCD configuration in the SoC. Default configuration	Firmware will attempt to interleave all memory channels in the Socket.	12-way Interleave per Socket: {ABCDEFGHIJKL}
NPS0: One NUMA node per system.	Available on dual processor systems only.	Firmware will attempt to interleave all memory channels in the System.	24-way Interleave per System: {ABCDEFGHIJKL} from each socket

NOTE:

1. If the CCD configuration is altered by software (e.g., BIOS Setup Option), NPS4 or NPS2 configurations may not be available, based on the Symmetry requirements noted above.
2. Not all OPNs support NPS2 or NPS4, based on CCD configuration per package.

General memory module installation guidelines

To ensure optimal performance of your system, observe the following general guidelines when configuring your system memory. If your system's memory configuration fails to observe these guidelines, your system might not boot, stop responding during memory configuration, or operate with reduced memory.

The memory bus may operate at speeds of 6400 MT/s or lower depending on the following factors:

- System profile selected (for example, Performance, Performance Per Watt Optimized (OS), or Custom [can be run at high speed or lower])
- Maximum supported DIMM speed of the processors
- Maximum supported speed of the DIMMs

NOTE: MT/s indicates DIMM speed in Mega-Transfers per second.

The following are the recommended guidelines for installing memory modules:

- All DIMMs must be DDR5.
- DIMM mixing configurations are not supported. All DIMM slots must be populated with the exact same DIMMs.
- Populate memory module sockets only if a processor is installed.
 - A minimum of one DIMM must be populated for each installed processor.
- In **Optimizer Mode**, the DRAM controllers operate independently in the 64-bit mode and provide optimized memory performance.

Table 75. Memory population rules

Processor	Memory population	Memory population information
Dual processor (Start with processor 0. Processor 0 and processor 1 population should match)	A{1}, B{1}, A{2}, B{2}, A{3}, B{3}, A{4}, B{4}, A{5}, B{5}, A{6}, B{6}, A{7}, B{7}, A{8}, B{8}, A{9}, B{9}, A{10}, B{10}, A{11}, B{11}, A{12}, B{12},	1, 2, 4, 6, 8, 10, 12 DIMMs are allowed.

- In a dual-processor configuration, the memory configuration for each processor must be identical. For example, if you populate socket A1 for processor 1, then populate socket B1 for processor 2, and so on.
- Unbalanced or odd memory configurations result in a performance loss, and the system may not identify the memory modules being installed. Always populate memory channels identically with equal DIMMs for the best performance.
- For best performance, populate all memory channels equally (12 DIMMs per CPU) using identical DIMMs.

- Mixing of any different memory module capacities is not supported.
- Mixing module types within a memory channel is not supported. All DIMMs populated must be RDIMM.
- Mixing different widths (x4 and x8) is not supported.

NOTE: If memory modules with different speeds are installed, they operate at the speed of the slowest installed memory module(s).

Removing a memory module

Prerequisites

1. Follow the safety guidelines listed in the [Safety instructions](#).
2. Follow the procedure listed in [Before working inside your system](#).
3. [Remove the air shroud](#).

WARNING: The memory modules are hot to touch for some time after the system has been powered off. Allow the memory modules to cool before handling them.

NOTE: For proper system cooling, DIMM blanks must be installed in any memory socket that is not populated, only if the processor TDP is greater than 250 W. Remove the memory module blanks only if you intend to install the memory module in these sockets.

Steps

1. Locate the appropriate memory module socket.
2. To release the memory module from the socket, simultaneously press the ejectors on both ends of the memory module socket to fully open.

CAUTION: Handle each memory module only by the card edges, ensuring not to touch the middle of the memory module or metallic contacts.

3. Lift the memory module away from the system.

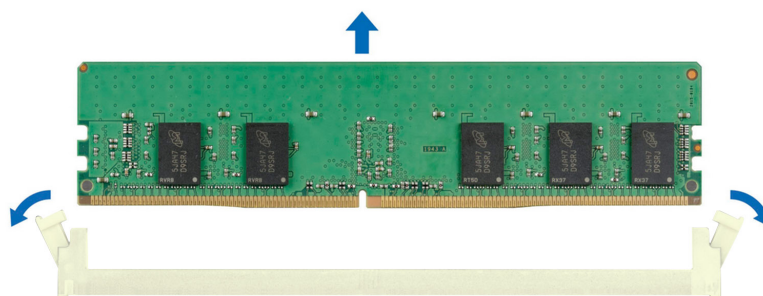

Figure 93. Removing a memory module

Next steps

[Replace the memory module](#).

Installing a memory module

Prerequisites

1. Follow the safety guidelines listed in the [Safety instructions](#).
2. Follow the procedure listed in [Before working inside your system](#).
3. [Remove the air shroud](#).

Steps

1. Locate the appropriate memory module socket.

CAUTION: Handle each memory module only by the card edges, ensuring not to touch the middle of the memory module or metallic contacts.

NOTE: Ensure that the socket ejector latches are fully open before installing the memory module.

2. Align the edge connector of the memory module with the alignment key of the memory module socket, and insert the memory module in the socket.

CAUTION: To prevent damage to the memory module or the memory module socket during installation, do not bend or flex the memory module. Insert both ends of the memory module simultaneously.

NOTE: The memory module socket has an alignment key that enables you to install the memory module in the socket in only one orientation.

CAUTION: Do not apply pressure at the center of the memory module; apply pressure at both ends of the memory module evenly.

3. Press the memory module with your thumbs until the ejectors firmly click into place. When the memory module is properly seated in the socket, the memory module socket levers align with the levers on the other sockets that have memory modules that are installed.

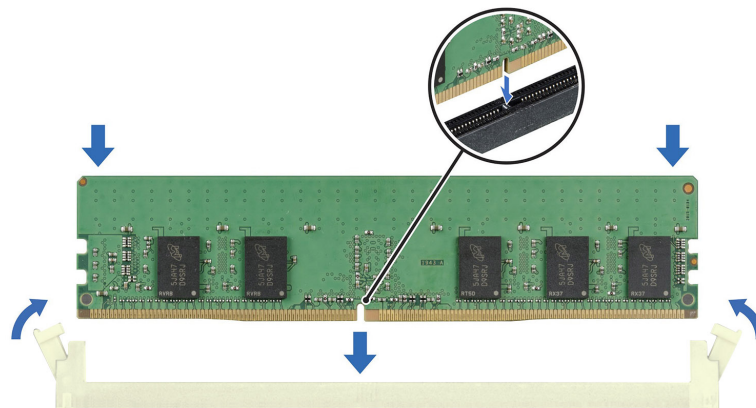

Figure 94. Installing a memory module

Next steps

1. Follow the procedure listed in [After working inside your system](#).
2. To verify that the memory module has been installed properly, press **F2** during reboot and click **System Setup Main Menu > System BIOS > Memory Settings**. In the **Memory Settings** screen, the **System Memory Size** must reflect the updated capacity of the installed memory.
3. If the **System Memory Size** is incorrect, one or more of the memory modules may not be installed properly. Shut down the system and ensure that the memory modules are firmly seated in the correct sockets.

4. Run the system memory test in system diagnostics.

Direct Liquid Cooling (DLC) module mid bracket

Removing a Direct Liquid Cooling (DLC) mid bracket

Prerequisites

1. Follow the safety guidelines listed in the [Safety instructions](#).
2. Follow the procedure listed in [Before working inside your system](#).
3. [Remove the air shroud](#).
4. If required, [remove the expansion card riser](#).
5. [Remove DLC tubes from the narrow side of the mid bracket](#).

Steps

Loosen the captive screws on the mid bracket and lift it up from the system.

 **NOTE:** The removal steps are similar on all liquid cooling mid brackets.

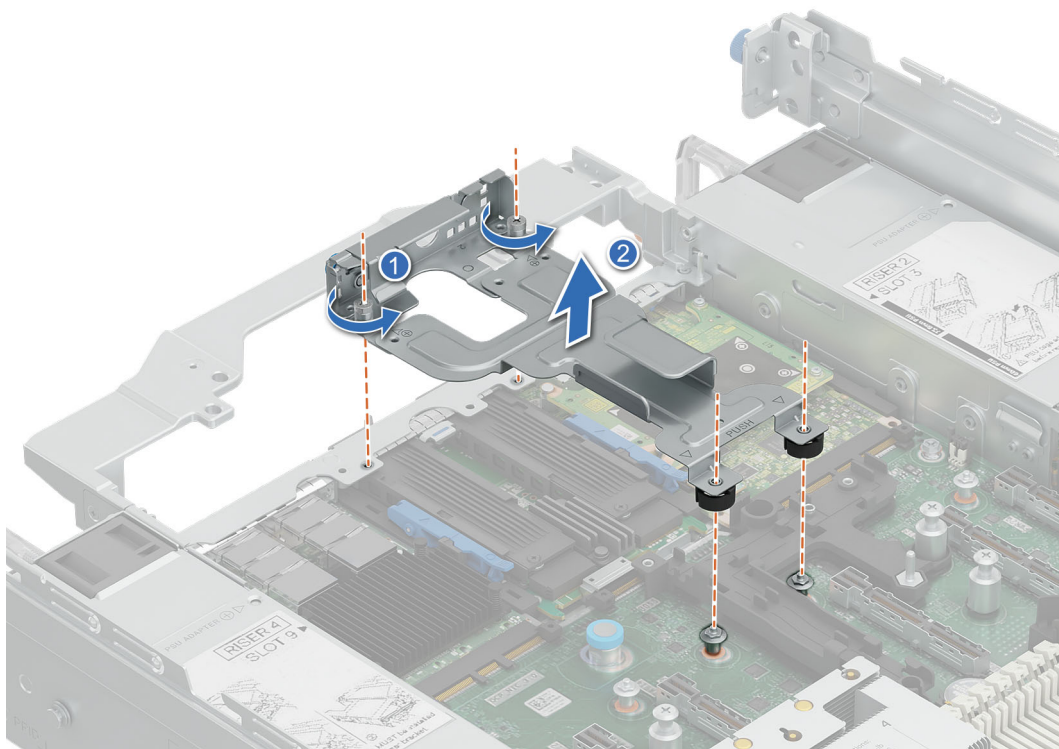

Figure 95. Removing the short liquid cooling mid bracket

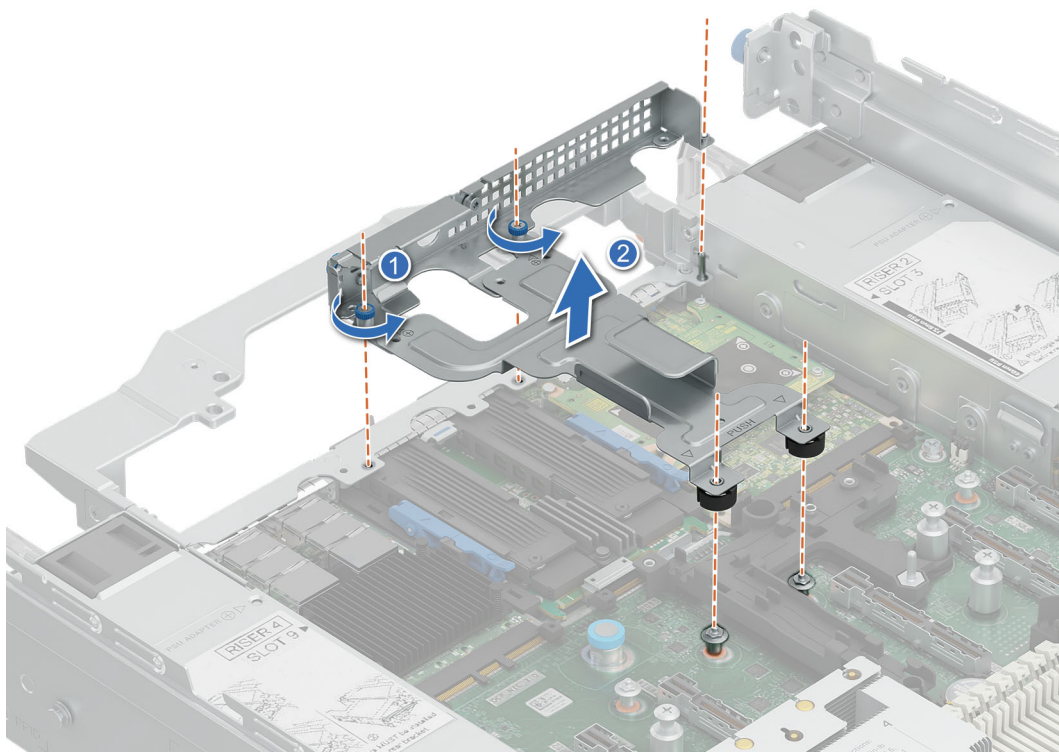

Figure 96. Removing the low profile liquid cooling mid bracket

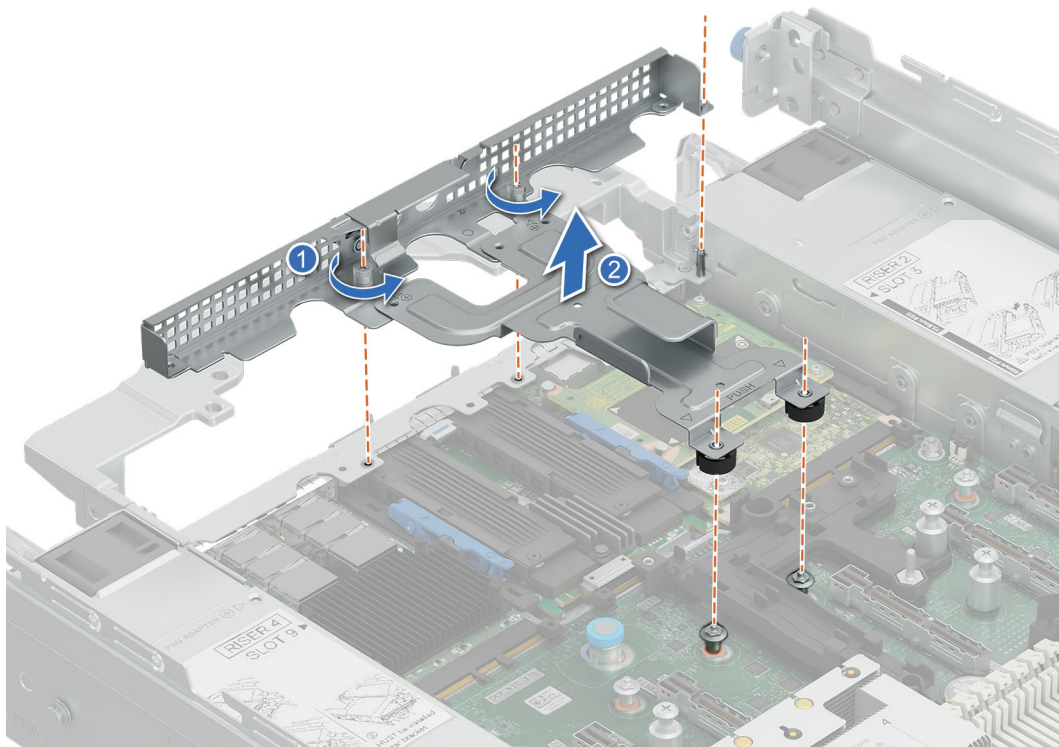

Figure 97. Removing the liquid cooling long mid bracket

Next steps

1. Route and secure the DLC tubes from the narrow side of the mid bracket.
2. If required, replace the expansion card riser.
3. Replace the shroud

Installing a Direct Liquid Cooling (DLC) mid bracket

Prerequisites

1. Follow the safety guidelines listed in the [Safety instructions](#).
2. Follow the procedure listed in [Before working inside your system](#).
3. [Remove the air shroud](#)
4. [Remove the expansion card risers](#).
5. [Remove the DLC tubes](#).

Steps

1. For the short mid bracket, align the bracket with the screw holes on the chassis and HPM board.
2. For the long and low-profile mid bracket, align the bracket with the screw holes and guide pins on the chassis and HPM board.
3. Tighten the captive screws on the mid bracket to secure it in place.

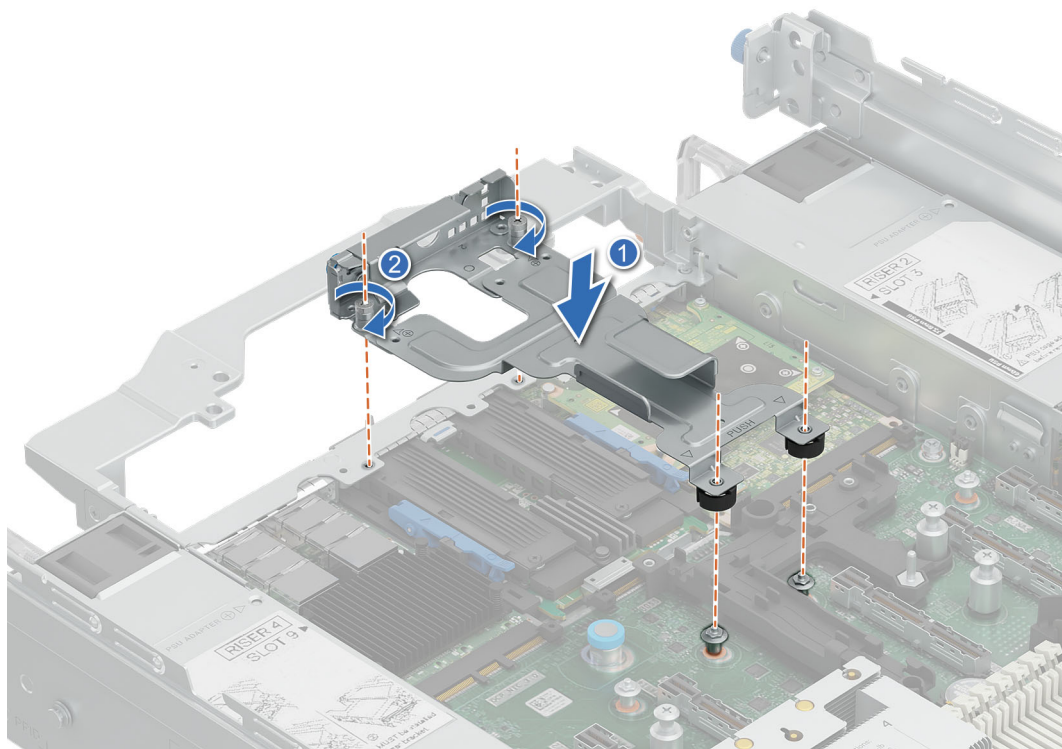

Figure 98. Installing the short DLC mid bracket

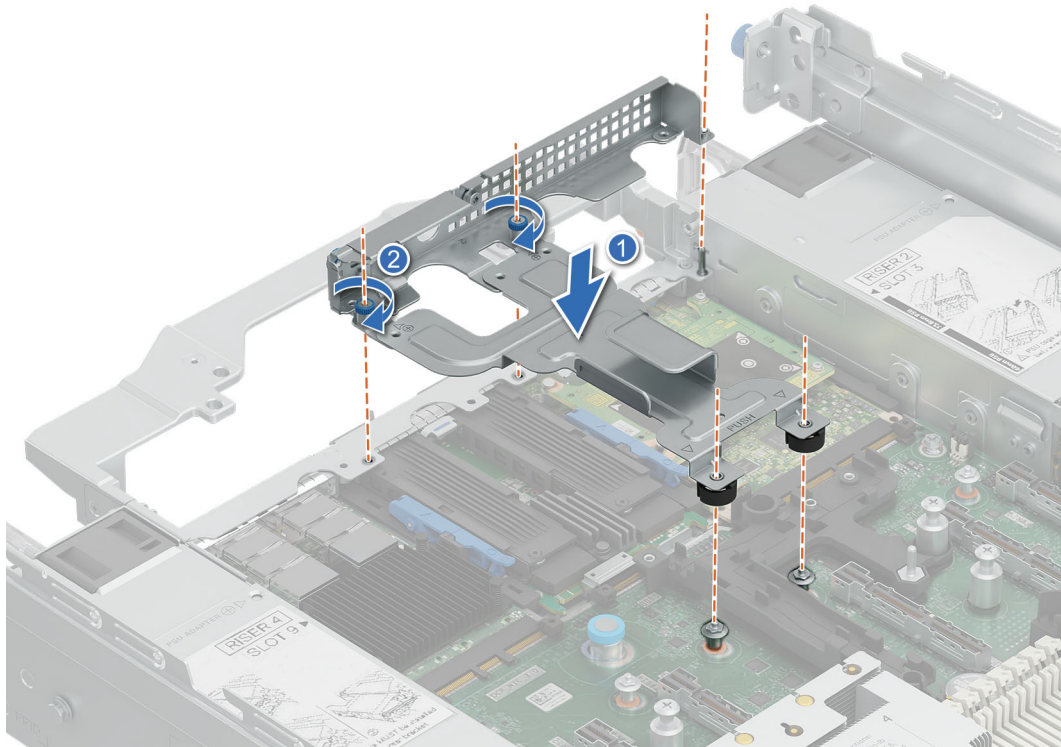

Figure 99. Installing the low profile DLC mid bracket

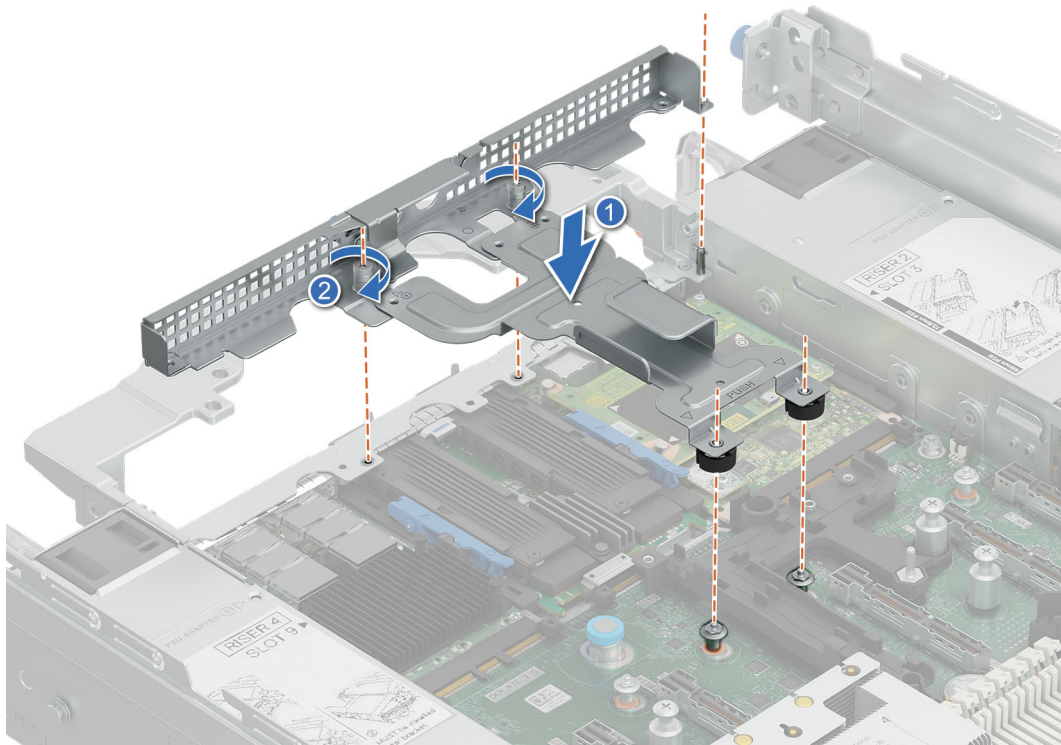

Figure 100. Installing the long DLC mid bracket

Next steps

1. [Route the liquid cooling tubes in place.](#)
2. [Install the expansion card risers.](#)
3. [Install the air shroud.](#)
4. Follow the procedure listed in [After working inside your system.](#)

Processor and heat sink

This is a service technician replaceable part only.

Removing the heat sink module

Prerequisites

1. Follow the safety guidelines listed in the [Safety instructions.](#)
2. Follow the procedure listed in [Before working inside your system.](#)
3. [Remove the air shroud.](#)

NOTE: The heat sink and processor are hot to touch for some time after the system has been powered off. Allow the heat sink and processor to cool down before handling them.

4. The system supports different to types of heatsinks and the procedure to remove them are similar.

Steps

1. Using a Torx #T20 screwdriver, fully loosen the captive screw all the way before moving to the next screw (on a one-screw-at-a-time basis).

NOTE: Follow the screw sequence defined on the heat sink label. Disassembly order: 6, 5, 4, 3, 2, 1

NOTE: The captive screw numbers are marked on the heat sink.

2. Lift the heat sink from the system.

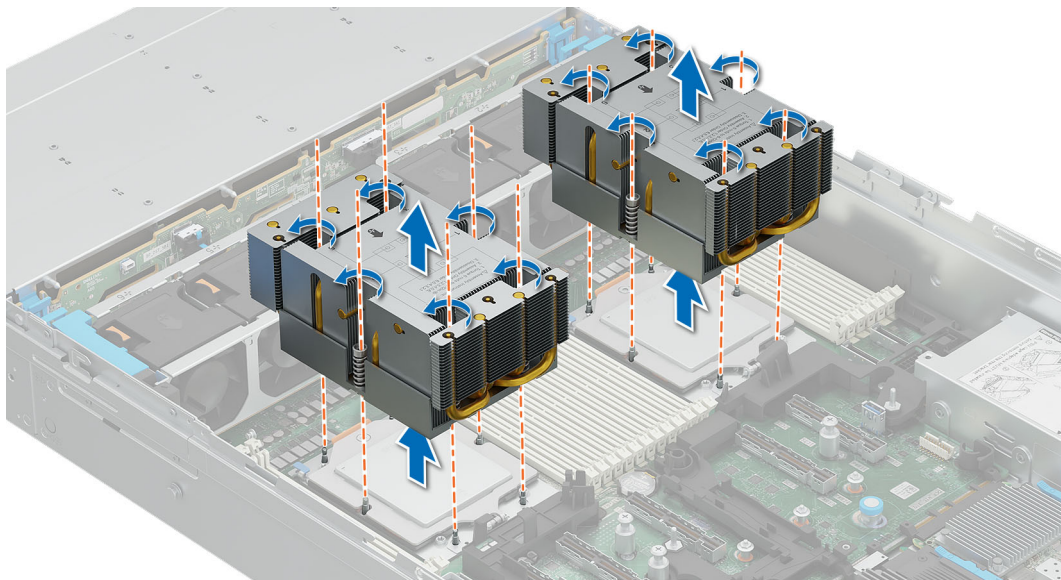

Figure 101. Removing a heat sink

Next steps

If you are removing a faulty heat sink, [replace the heat sink](#), if not, [remove the processor](#).

Removing the Direct Liquid Cooling (DLC) module

Prerequisites

1. Follow the safety guidelines listed in the [Safety instructions](#).
2. Follow the procedure listed in the [Before working inside your system](#).
3. If installed, [remove the expansion card riser](#).

⚠ WARNING: The Direct liquid cooling (DLC) module and processor are too hot to touch for some time after the system has been powered off. Allow the liquid cooling module and processor to cool down before handling them.

Steps

1. Using a Phillips 2 screw driver, loosen the captive screw on the DLC tube cover.
2. Lift the DLC tube cover to loosen the DLC tubes.

i NOTE: The numbers on the image do not depict the exact steps. The numbers are for representation of a sequence.

3. Remove the tubes from the narrow side on the mid bracket.
4. Disconnect the DLC leak sensor cable from the HPM board.
5. Lift the tubes from the mid holder and then from the left holder and right holder.

i NOTE: The holder here is the black triangle plastic that is located next to the DIMM slots, holding the tubes together. This plastic holder can be removed from the HPM board for easier routing of the tubes. It can then be placed back on to the HPM board by pressing it down until it clicks into place.

6. Using a Torx T20 screwdriver, fully loosen the captive screw all the way before moving to the next screw on a one-screw-at-a-time basis).

i NOTE: Follow the screw sequence defined on the heat sink label. Disassembly order: 6, 5, 4, 3, 2, 1.

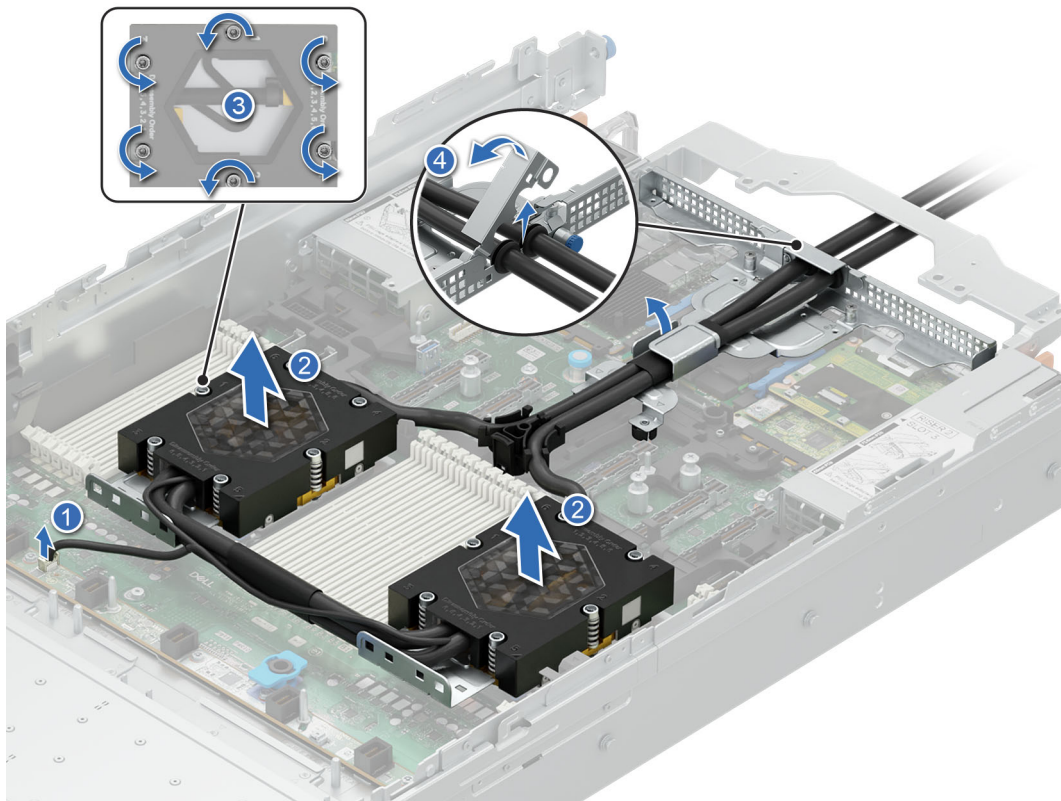

Figure 102. Removing the DLC module

7. Remove the DLC module from the system.

Next steps

1. If you are uninstalling a faulty heat sink, [replace the DLC module](#), else [remove the processor](#).

Removing the processor

Prerequisites

1. Follow the safety guidelines listed in the [Safety instructions](#).
2. Follow the procedure listed in [Before working inside your system](#).
3. [Remove the air shroud](#).
4. [Remove the heat sink module](#).

⚠ CAUTION: You may find the CMOS battery loss or CMOS checksum error that is displayed during the first instance of powering on the system after the processor or HPM board replacement which is expected. To fix this, go to setup option to configure the system settings.

Steps

1. Using a Torx #T20 screwdriver, loosen the middle screw to release the retention frame. Hold and lift the retention frame upwards and rotate it slightly past the vertical position(105 degrees).

i NOTE: The spring loading keeps the retention frame at its "open" position.

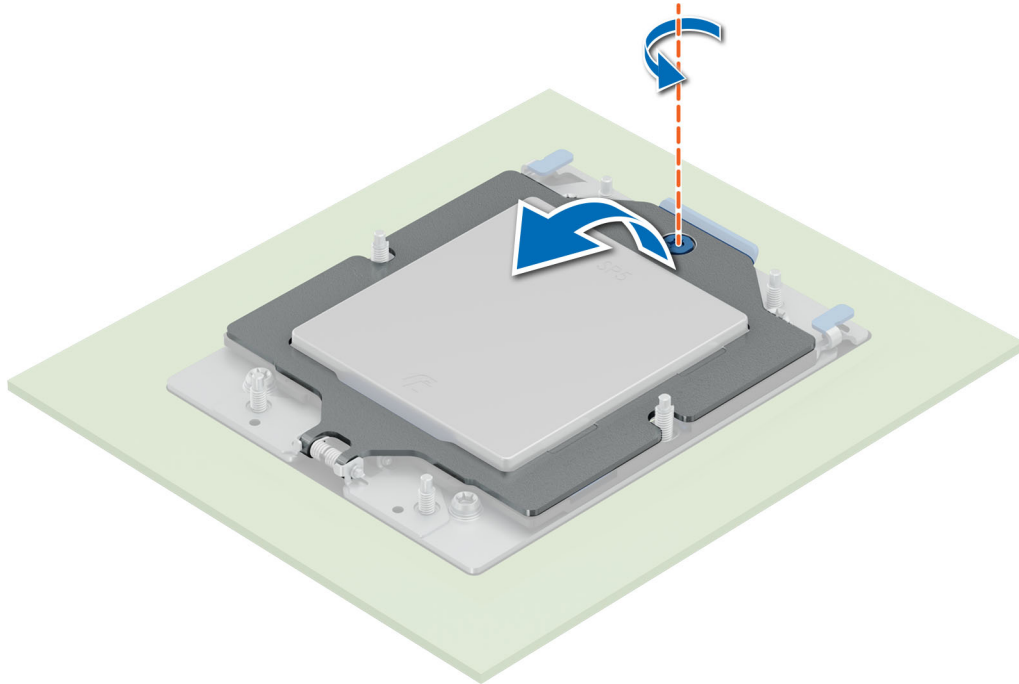

Figure 103. Removing screws on the retention frame

2. Release the processor socket rail frame by holding both blue tabs to lift the blue latches.

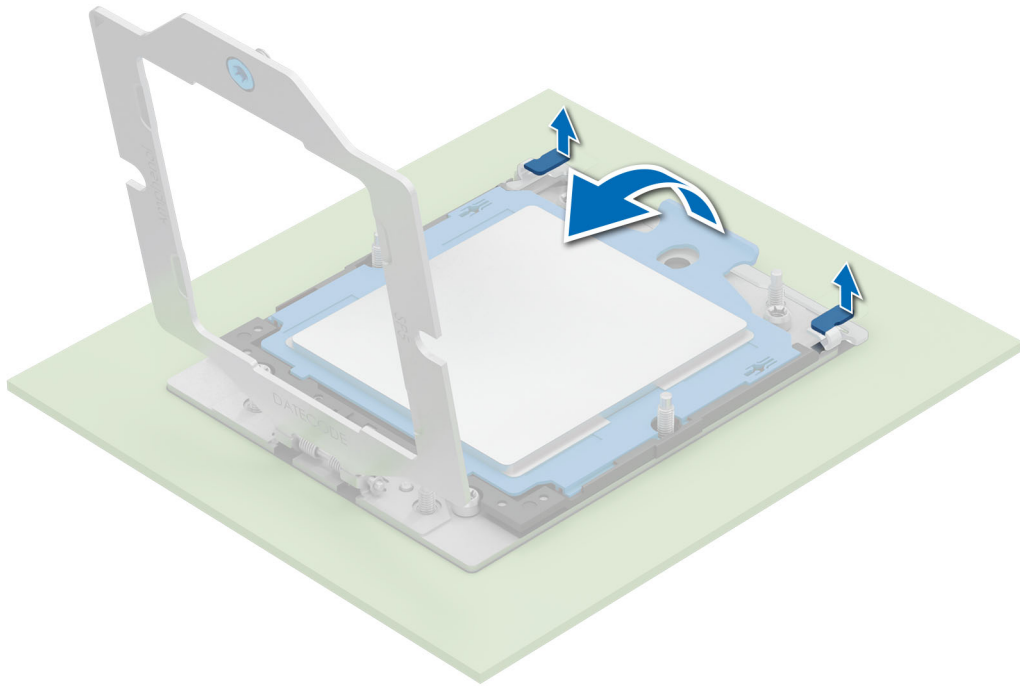

Figure 104. Lifting the rail frame

3. Holding the handle on the carrier frame, slide the tray out of the rail frame.

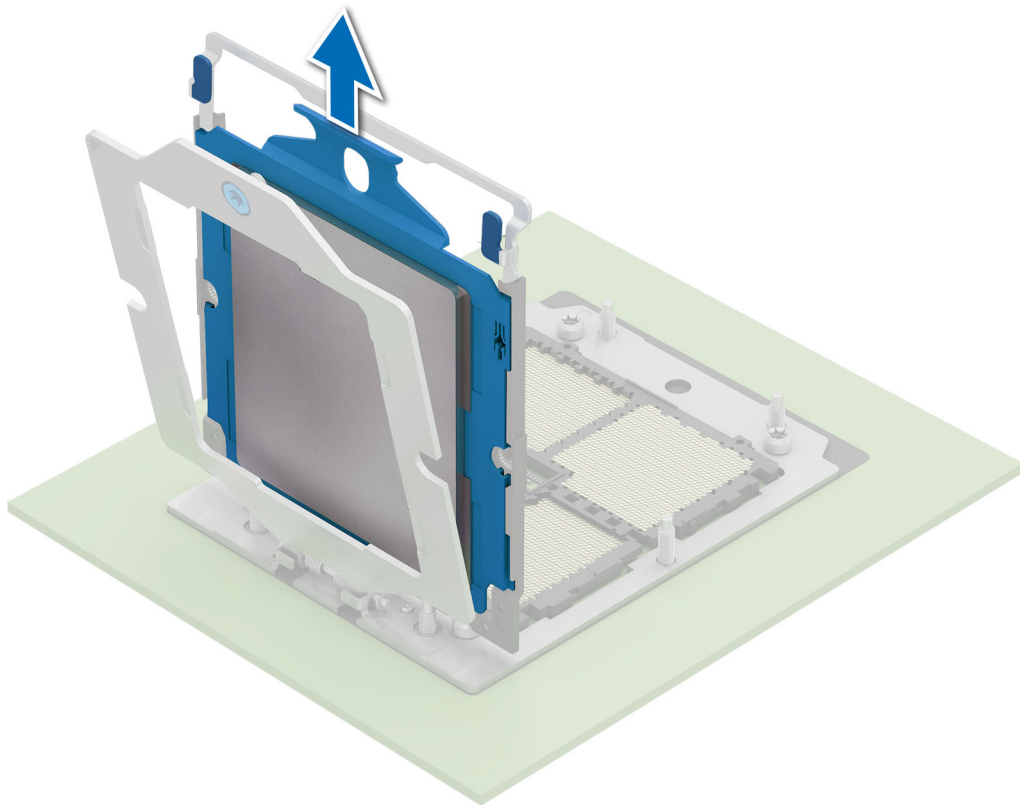

Figure 105. Removing the carrier frame

Next steps

Replace the processor.

Installing the processor

Prerequisites

1. Follow the safety guidelines listed in the [Safety instructions](#).
2. Follow the procedure listed in [Before working inside your system](#).
3. [Remove the air shroud](#).
4. [Remove the heat sink module](#).

Steps

1. Holding the handle of the carrier frame, slide the tray into the processor socket rail frame until firmly seated.

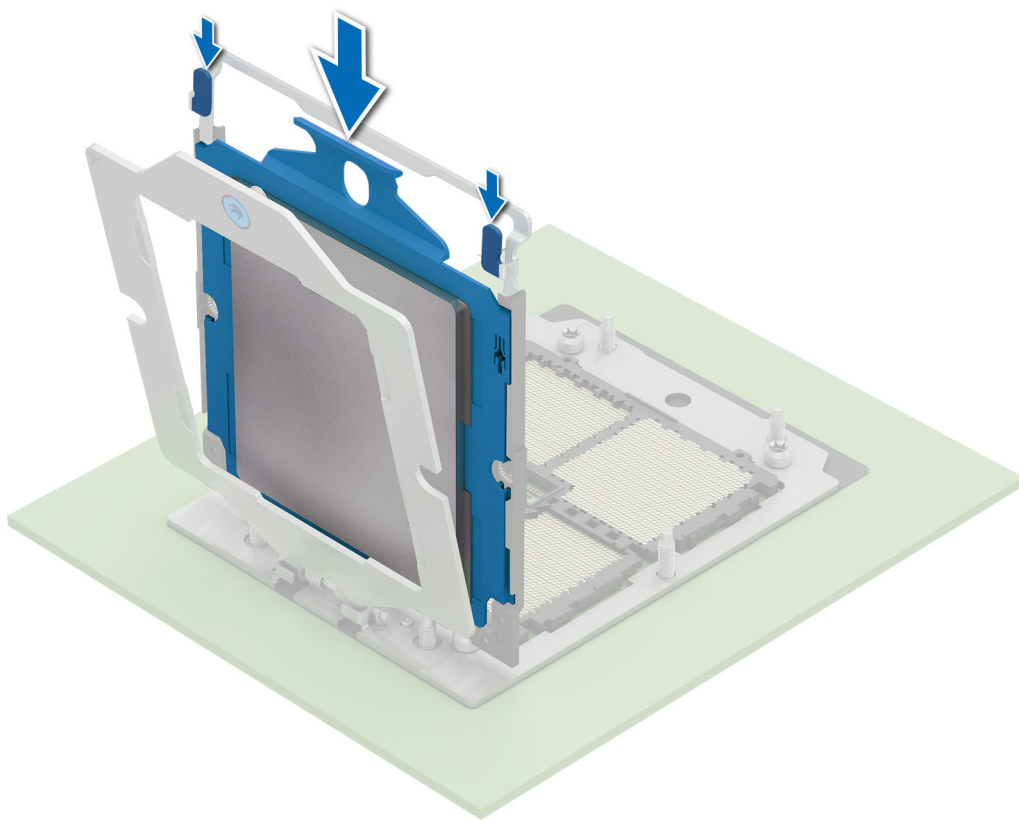

Figure 106. Placing the carrier frame into the rail frame

2. Holding both of blue tabs to push the rail frame down until the blue latches lock into place.

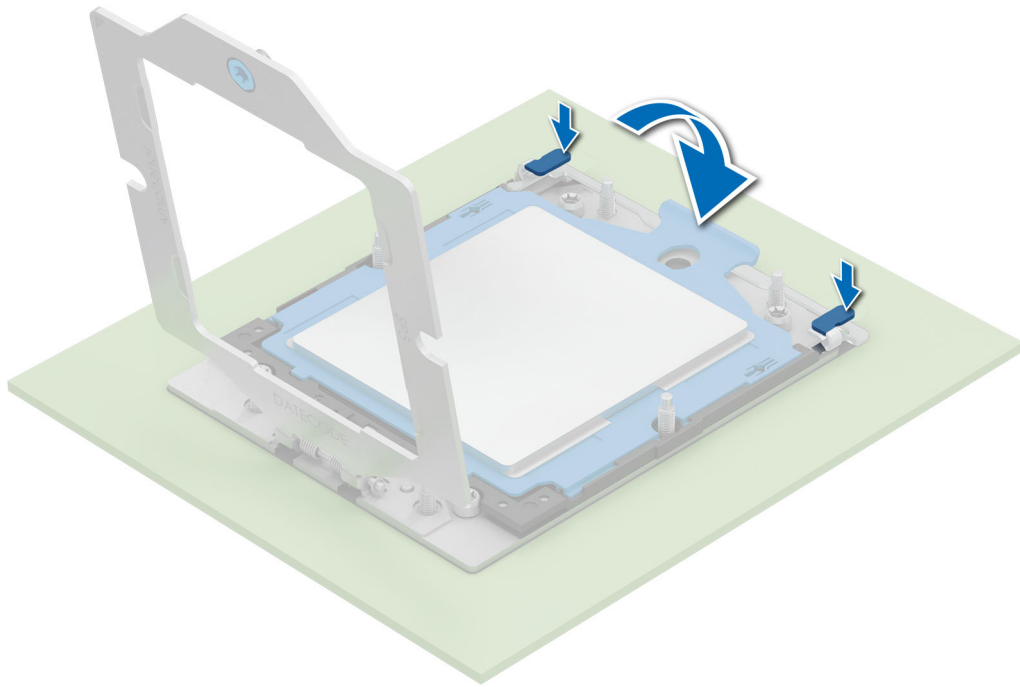

Figure 107. Closing the rail frame

3. Secure the retention frame by holding down the retention frame with one hand while using the other hand to operate the screw driver to engage and tighten the screw.

i **NOTE:** Press the retention frame while tightening the screws to avoid tilting of the processor cover out of the processor socket.

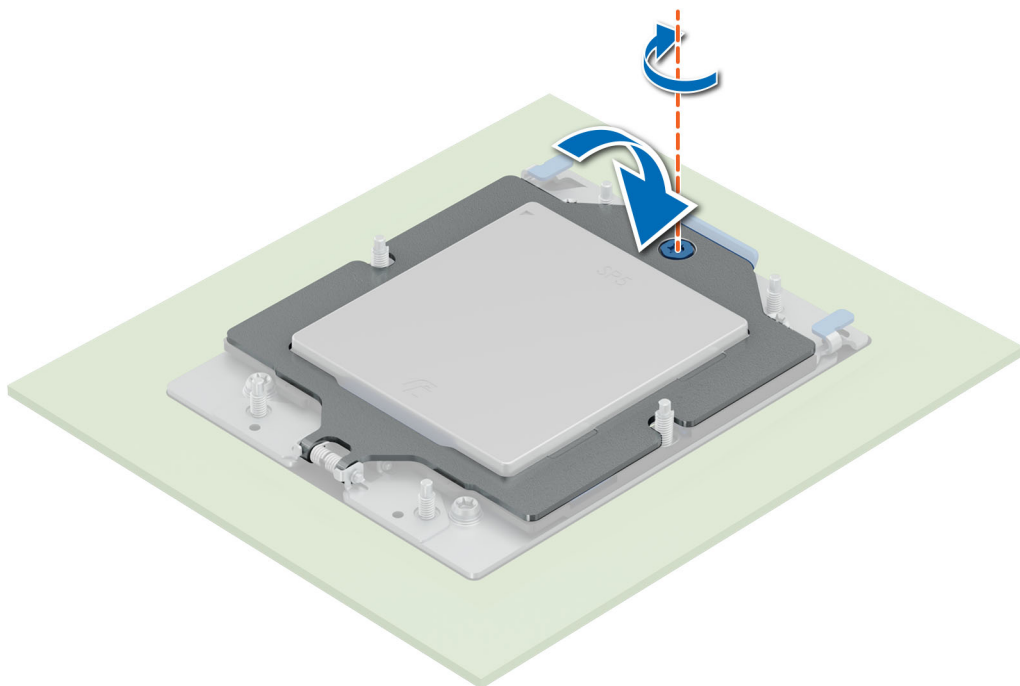

Figure 108. Securing the retention frame

Next steps

1. [Install the heat sink module.](#)
2. [Install the air shroud.](#)
3. Follow the procedure listed in [After working inside your system.](#)

Installing the heat sink module

Prerequisites

Never remove the heat sink from a processor unless you intend to replace the processor or heat sink. The heat sink is necessary to maintain proper thermal conditions.

1. Follow the safety guidelines listed in the [Safety instructions.](#)
2. Follow the procedure listed in [Before working inside your system.](#)
3. [Remove the air shroud.](#)
4. If installed, remove the processor dust cover.
5. The system supports different to types of heatsinks and the procedure to install them are similar.

Steps

1. If you are using an existing heat sink, remove the thermal grease on the heat sink by using the provided presaturated alcohol wipe.

i **NOTE:** For a new heat sink, the thermal paste is pre-applied to the heat sink. Remove the protective cover, and install the heat sink.

2. Use the thermal grease syringe included with your processor kit to apply the grease in a thin quadrilateral spiral on the top of the processor.

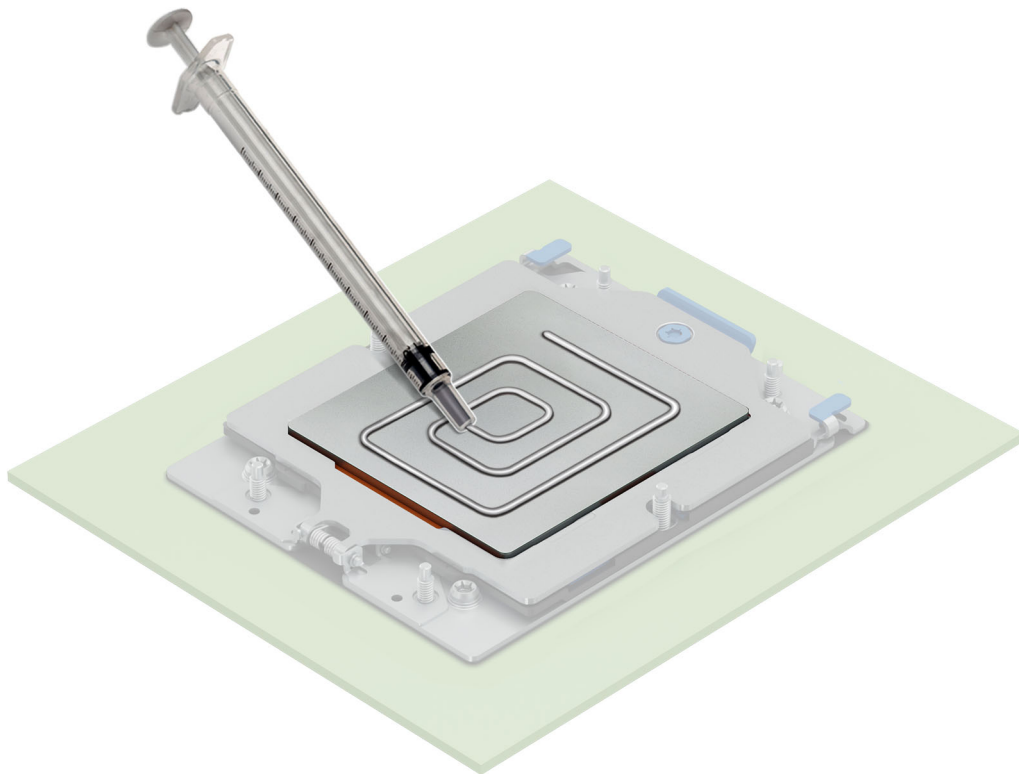

Figure 109. Applying thermal grease

⚠ CAUTION: Applying too much thermal grease can result in excess grease coming in contact with and contaminating the processor socket.

i **NOTE:** The thermal grease syringe is intended for single use only. Dispose of the syringe after you use it.

NOTE: Refer to the airflow direction on the heat sink label as visual hint of heat sink install orientation.

3. Align the screws on the heat sink with the standoff screws on the HPM board.
4. Using a Torx #T20 screwdriver, fully tighten the captive screw all the way down before moving to the next screw (on a one-screw-at-a-time basis).

NOTE: Follow the screw sequence defined on the heat sink label. Assembly order: 1, 2, 3, 4, 5, 6

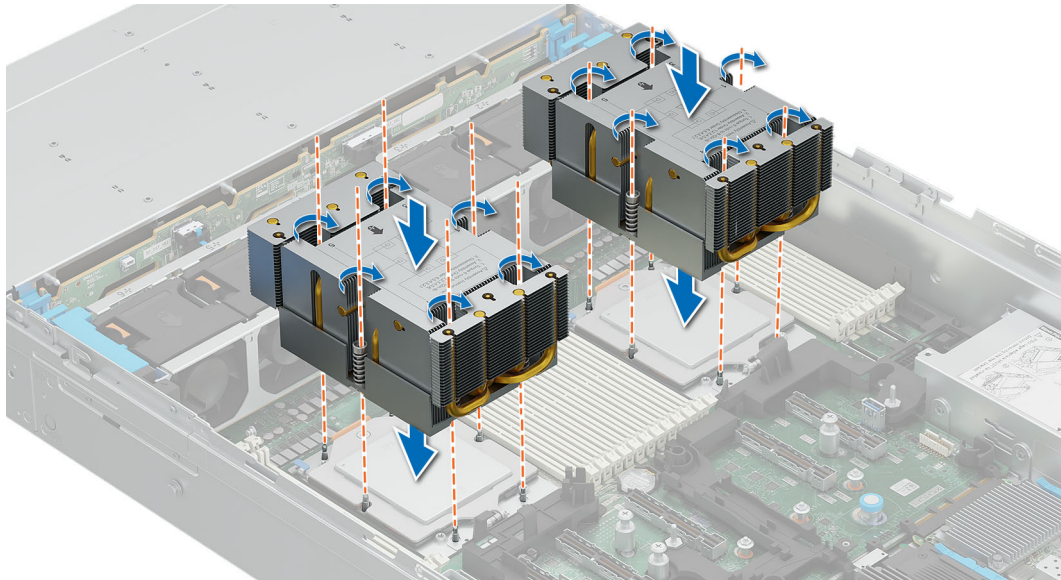

Figure 110. Installing the heat sink

Next steps

1. [Install the air shroud.](#)
2. Follow the procedure listed in the [After working inside your system.](#)

Installing the Direct Liquid Cooling (DLC) module

Prerequisites

Never uninstall the heat sink from a processor unless you intend to replace the processor or system board. The heat sink is necessary to maintain proper thermal conditions.

1. Follow the safety guidelines listed in the [Safety instructions.](#)
2. Follow the procedure listed in the [Before working inside your system.](#)
3. If installed, [remove expansion card riser.](#)
4. For new heat sinks, see [Installing the heat sink](#) step 1 and 2 for applying the thermal grease.

NOTE: The recommended maximum operating pressure is 15 psi (the diverter opens at 15 psi).

Steps

1. If required, [install the DLC mid bracket.](#)
2. Align the DLC module with the standoff screws on the HPM board.
3. Using a Torx T20 screwdriver, fully tighten the captive screw all the way down before moving to the next screw on a one-screw-at-a-time basis).

NOTE: Follow the screw sequence defined on the heat sink label. Assembly order: 1, 2, 3, 4, 5, 6.

4. Route the DLC tubes and clip the right tube into the right holder, the left tube into the left holder, and both tubes into the mid holder.

NOTE: The holder here is the black triangle plastic that is located next to the DIMM slots, holding the tubes together. This plastic holder can be removed from the HPM board for easier routing of the tubes. It can then be placed back on to the HPM board by pressing it down until it clicks into place.

5. Install the mid holder into the HPM board.
6. Connect the DLC leak sensor cable to the HPM board.
7. Install both tubes into the narrow side of the mid bracket.
8. Open the mid bracket tube cover and align the tube rubber rings with the ring holders.

NOTE: Follow the number labels on the liquid cooling tubes and ring holders (1,2).

9. Tilt the tube cover to close. Using a Phillips 2 screwdriver, tighten the captive screw on the tube cover to secure it in place.

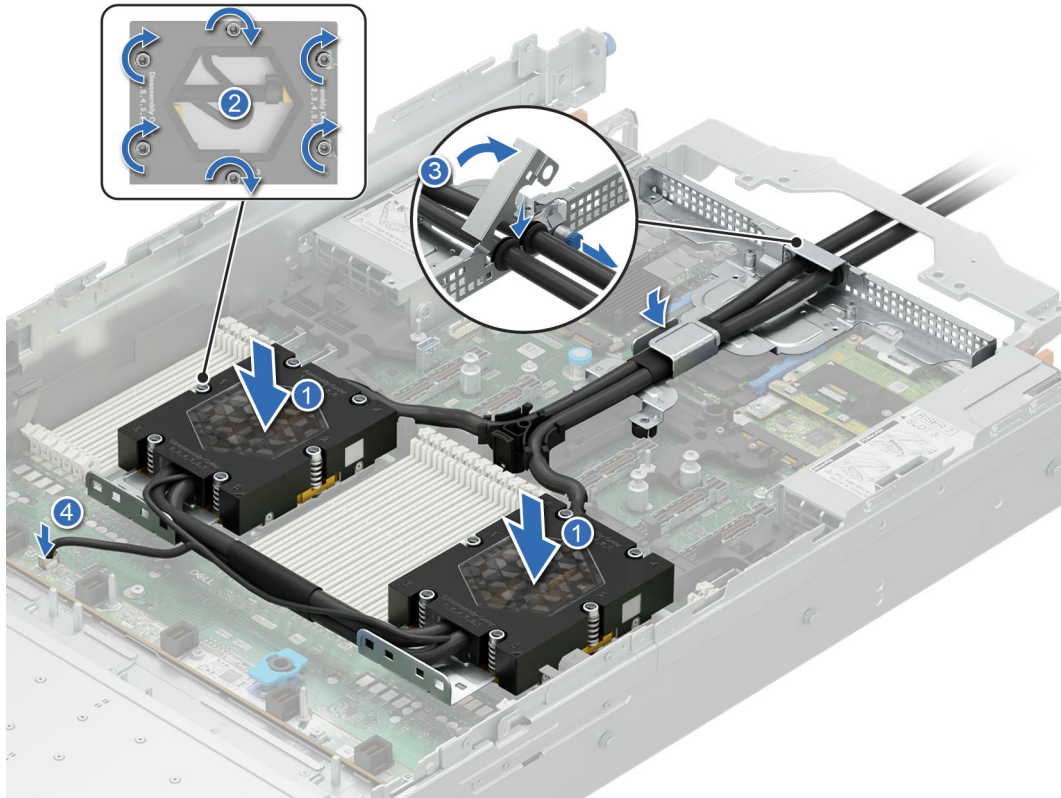

Figure 111. Installing the DLC module

Next steps

1. If removed, [install the expansion card riser](#).
2. Follow the procedure listed in the [After working inside your system](#).

Expansion cards and expansion card risers

NOTE: When an expansion card is not supported or missing, the iDRAC logs an event. This does not prevent your system from booting. However, if a F1/F2 pause occurs with an error message, see [EEMI guide](#).

Expansion card installation guidelines

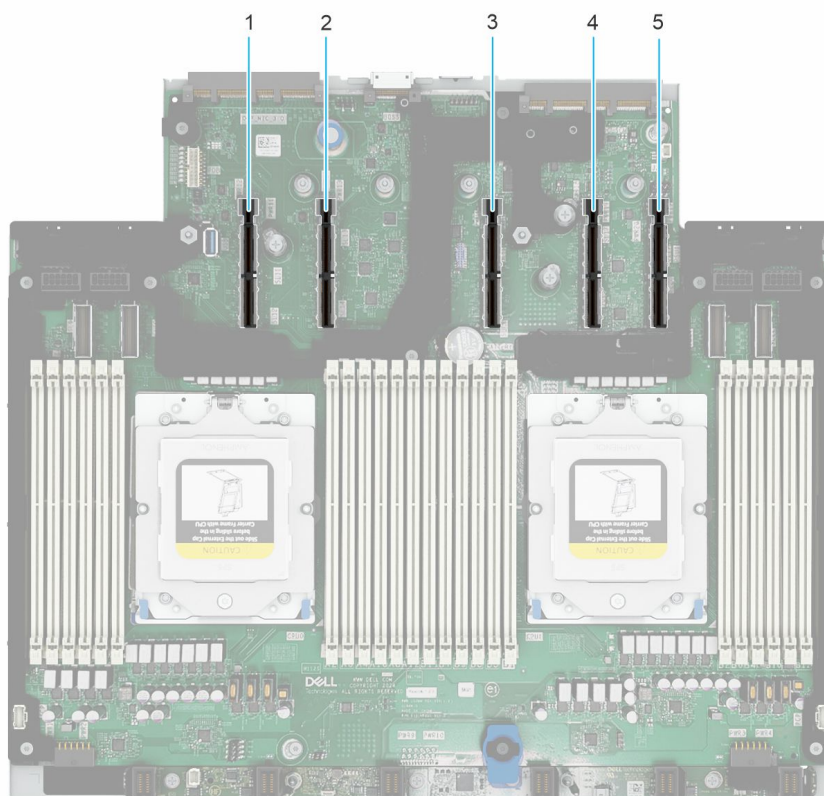

Figure 112. Expansion card riser slot connectors

1. Riser Connector 5
2. Riser Connector 4
3. Riser Connector 3
4. Riser Connector 1
5. Riser Connector 2

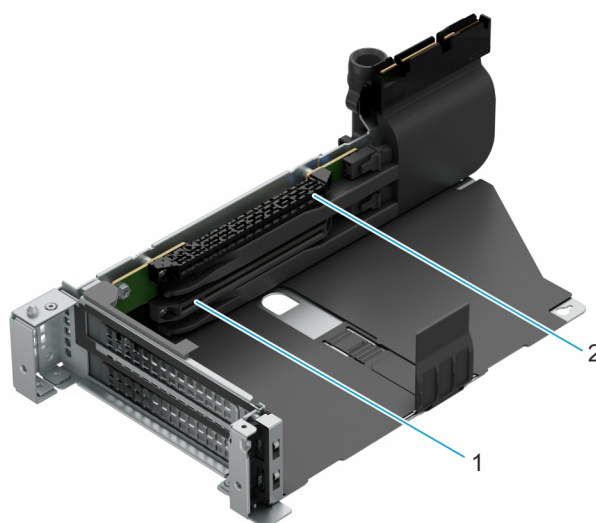

Figure 113. Riser 1a

1. Slot 1
2. Slot 2

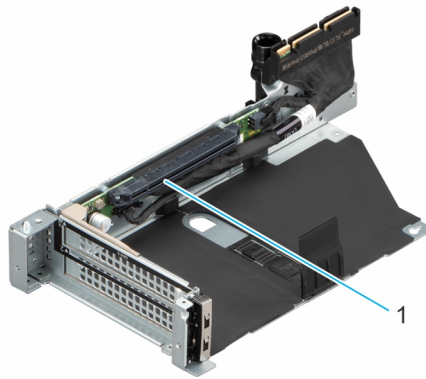

Figure 114. Riser 1b

1. Slot 2

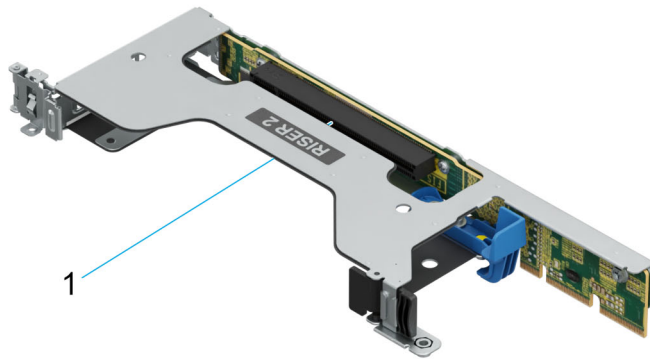

Figure 115. Riser 2a

1. Slot 3

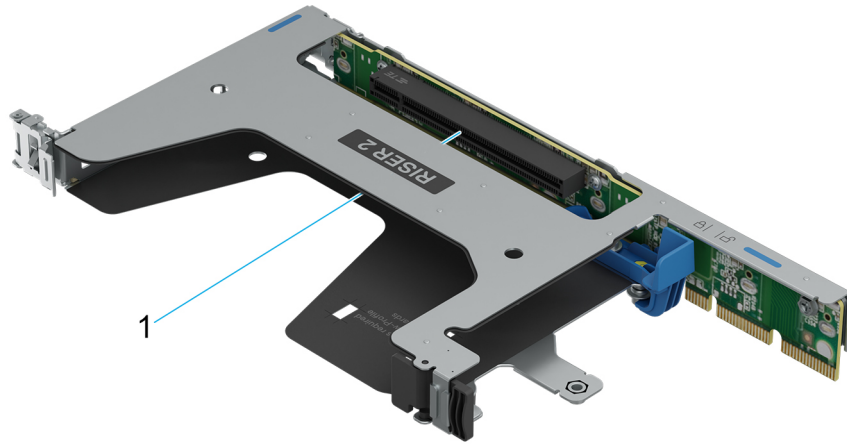

Figure 116. Riser 2b

1. Slot 3

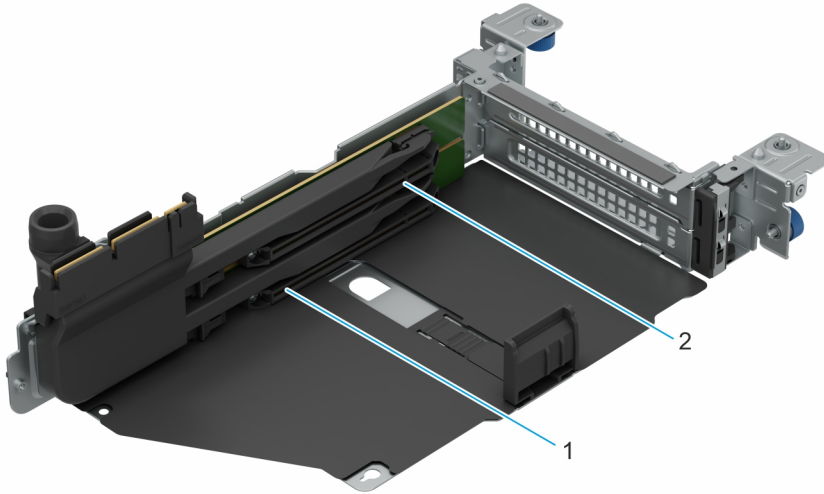

Figure 117. Riser 3a

1. Slot 4
2. Slot 5

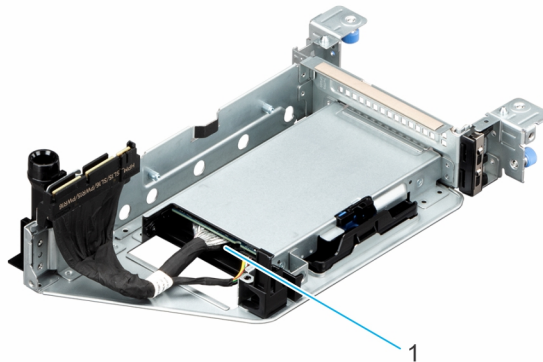

Figure 118. Riser 3e

1. Slot 4

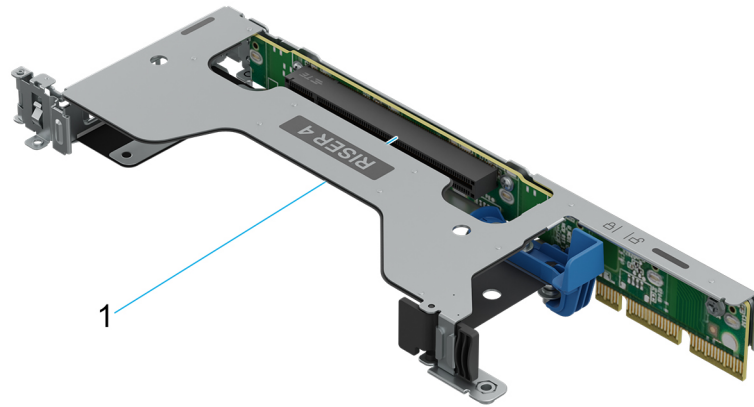

Figure 119. Riser 4a

1. Slot 9

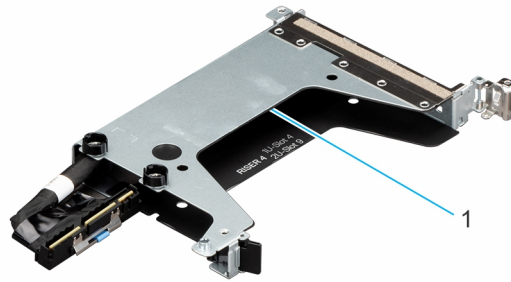

Figure 120. Riser 4b

1. Slot 9

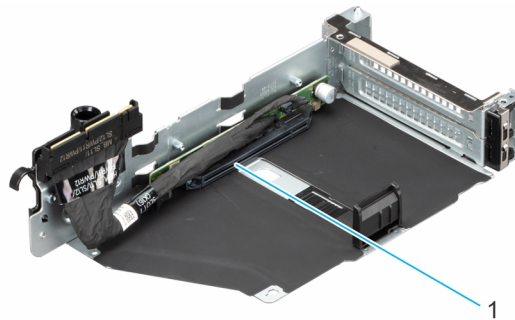

Figure 121. Riser 5b

1. Slot 7

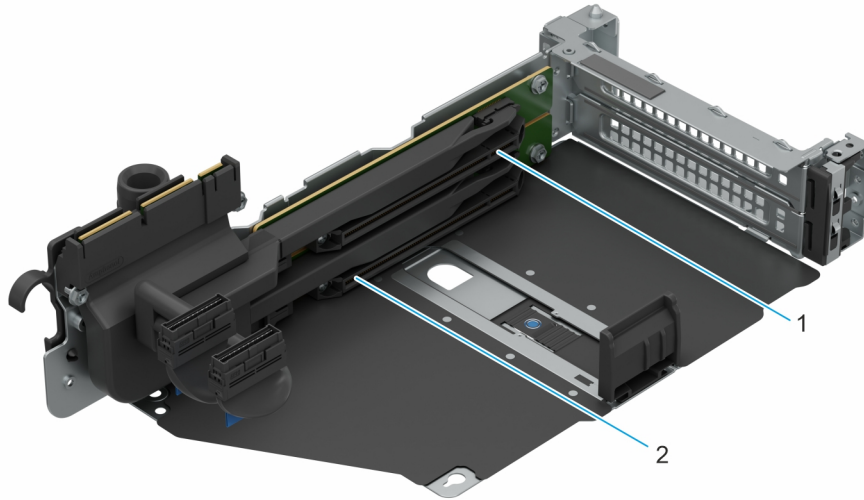

Figure 122. Riser 5e

1. Slot 7
2. Slot 8

NOTE: The expansion-card slots are not hot-swappable.

The following table provides guidelines for installing expansion cards to ensure proper cooling and mechanical fit. The expansion cards with the highest priority should be installed first using the slot priority indicated. All the other expansion cards should be installed in the card priority and slot priority order.

Expansion card riser configurations

Table 76. Expansion card riser configurations

Riser Configurations (RC)	Expansion card risers	PCIe Slots	Form factor	Controlling processor	Slot electrical bandwidth/ physical connector
RC 2: 2 x16 FH (Gen5) + 2 x16 OCP (Gen5) + optional BOSS	R1b	2	Full height	Processor 1	PCIe Gen5 x16 (x16 connector)
	R5b	7	Full height	Processor 0	PCIe Gen5 x16 (x16 connector)
	BOSS	6	BOSS	Processor 0	PCIe Gen3 x4 (1C connector)
	OCP 3	10	OCP	Processor 0	PCIe Gen5 x16 (OCP 4C+ connector)
RC 3: 4 x16 FH (Gen5) + 2 x16 OCP (Gen5) + optional BOSS	R1b	2	Full height	Processor 1	PCIe Gen5 x16 (x16 connector)
	R2b	3	Full height	Processor 1	PCIe Gen5 x16 (x16 connector)
	R3e	4	OCP	Processor 1	PCIe Gen5 x16 (OCP 4C+ connector)
	R4b	9	Full height	Processor 0	PCIe Gen5 x16 (x16 connector)

Table 76. Expansion card riser configurations (continued)

Riser Configurations (RC)	Expansion card risers	PCIe Slots	Form factor	Controlling processor	Slot electrical bandwidth/ physical connector
	R5b	7	Full height	Processor 0	PCIe Gen5 x16 (x16 connector)
	BOSS	6	BOSS	Processor 0	PCIe Gen3 x4 (1C connector)
	OCP 3	10	OCP	Processor 0	PCIe Gen5 x16 (OCP 4C+ connector)
RC 4: 2 x16 LP + 2 x16 DW + 2 x16 OCP (Gen5) + optional BOSS	R1b	2	Low profile	Processor 1	PCIe Gen5 x16 (x16 connector)
	R2a	3	Low profile	Processor 1	PCIe Gen5 x16 (x16 connector)
	R3e	4	OCP 3	Processor 1	PCIe Gen5 x16 (OCP 4C+ connector)
	R4a	9	Low profile	Processor 0	PCIe Gen5 x16 (x16 connector)
	R5b (FL)	7	Full height	Processor 0	PCIe Gen5 x16 (x16 connector)
	BOSS	6	BOSS	Processor 0	PCIe Gen3 x4 (1C connector)
	OCP 3	10	OCP	Processor 0	PCIe Gen5 x16 (OCP 4C+ connector)
RC 5: 6 x16 FH + 2 x16 OCP (Gen5) + optional BOSS	R1b	2	Full height	Processor 1	PCIe Gen5 x16 (x16 connector)
	R2b	3	Full height	Processor 1	PCIe Gen5 x16 (x16 connector)
	R3b	4	Full height	Processor 1	PCIe Gen5 x16 (x16 connector)
	R4b	9	Full height	Processor 0	PCIe Gen5 x16 (x16 connector)
		7	Full height	Processor 0	PCIe Gen5 x16 (x16 connector)
	8	Full height			
	BOSS	6	BOSS	Processor 0	PCIe Gen3 x4 (1C connector)
OCP 3	10	OCP	Processor 0	PCIe Gen5 x16 (OCP 4C+ connector)	
RC 7: 6 x8 FH + 2 x16 FH + 2 x16 OCP (Gen5) + optional BOSS	R1a	1	Full height	Processor 1	PCIe Gen5 x8 (x16 connector)
		2	Full height	Processor 1	PCIe Gen5 x8 (x16 connector)
	R2b	3	Full height	Processor 1	PCIe Gen5 x16 (x16 connector)

Table 76. Expansion card riser configurations (continued)

Riser Configurations (RC)	Expansion card risers	PCIe Slots	Form factor	Controlling processor	Slot electrical bandwidth/ physical connector
	R3a	4	Full height	Processor 1	PCIe Gen5 x8 (x16 connector)
		5	Full height	Processor 1	PCIe Gen5 x8 (x16 connector)
	R4b	9	Full height	Processor 0	PCIe Gen5 x16 (x16 connector)
	R5a	7	Full height	Processor 0	PCIe Gen5 x8 (x16 connector)
		8	Full height	Processor 0	PCIe Gen5 x8 (x16 connector)
	BOSS	6	BOSS	Processor 0	PCIe Gen3 x4 (1C connector)
	OCP 3	10	OCP	Processor 0	PCIe Gen5 x16 (OCP 4C+ connector)
RC 8: 2 x16 FH (Gen5) + 2 x16 OCP (Gen5) + optional BOSS	R1b	2	Full height	Processor 1	PCIe Gen5 x16 (x16 connector)
	R3e	4	OCP	Processor 1	PCIe Gen5 x16 (OCP 4C+ connector)
	R5b	7	Full height	Processor 0	PCIe Gen5 x16 (x16 connector)
	BOSS	6	BOSS	Processor 0	PCIe Gen3 x4 (1C connector)
	OCP 3	10	OCP	Processor 0	PCIe Gen5 x16 (OCP 4C+ connector)

NOTE: Riser 1b and 5b supports DPU cards.

Table 77. RC 2: R1b+R5b

Card type	Slot priority	Maximum number of cards
NVIDIA (DPU: 200Gb)	2,7	2
NVIDIA (L4 GPU)	2,7	2
Foxconn (BOSS-N1)	6	1
Broadcom (OCP: 1Gb, 10Gb, 25Gb, 100Gb, 200Gb)	10	1
Intel (OCP: 1Gb, 10Gb)	10	1
Mellanox (OCP: 25Gb, 100Gb)	10	1
NVIDIA (NIC: NDR400)	2,7	2
Mellanox (NIC: 25Gb, 100Gb)	2,7	2
Marvell (HBA: FC32, FC64)	2,7	2
Broadcom (NIC: 25Gb, 100Gb, 200Gb)	2,7	2

Table 77. RC 2: R1b+R5b (continued)

Card type	Slot priority	Maximum number of cards
Emulex (HBA: FC32, FC64)	2,7	2
Foxconn (HBA465E, H965e Adapter)	2,7	1
NVidia BlueField-3 B3220	2,7	2

Table 78. RC 3: R1b+R2b+R3e+R4b+R5b

Card type	Slot priority	Maximum number of cards
Foxconn (PERC H365I, H965I)	7	1
Foxconn (Front PERC H365I)	Internal	1
Foxconn (Front HBA465I)	Internal	1
Foxconn (HBA465I)	7	1
NVIDIA (DPU: 200Gb)	2,7	2
NVIDIA (L4 GPU)	2,3,7,9	4
Foxconn (BOSS-N1)	6	1
Foxconn (Front PERC H965I, H975I)	Internal	2
Broadcom (OCP: 1Gb, 10Gb, 25Gb, 100Gb, 200Gb)	10,4	2
Intel (OCP: 1Gb, 10Gb)	10,4	2
Mellanox (OCP: 25Gb)	10,4	2
NVIDIA (NIC: NDR400)	2,7	2
Broadcom (NIC: 200Gb)	2,7	2
Broadcom (NIC: 25Gb, 100Gb)	2,3,7,9	4
Mellanox (NIC: 25Gb, 100Gb)	2,3,7,9	4
Marvell (HBA: FC32, FC64)	2,3,7,9	4
Emulex (HBA: FC32, FC64)	2,3,7,9	4
Smart Modular (CXL:type3)	3,9	2
Foxconn (PERC H965E)	2,3,7,9	1
Foxconn (HBA465E)	2,3,7,9	1
NVidia BlueField-3 B3220	2,7	2

Table 79. RC 4: R1b+R2a+R3e+R4a+R5b (FL)

Card type	Slot priority	Maximum number of cards
NVIDIA (DPU: 200Gb)	2,7	2
NVIDIA (GPU:L40S, H100, A16, H200NVL, RTXP6000, L4)	2,7	2
NVIDIA (L4 GPU)	3,9	2
Foxconn (BOSS-N1)	6	1
Foxconn (Front PERC H965I,H975I)	Internal	2
Foxconn (Front PERC H365I)	Internal	1
Foxconn (Front HBA465I)	Internal	1

Table 79. RC 4: R1b+R2a+R3e+R4a+R5b (FL) (continued)

Card type	Slot priority	Maximum number of cards
Broadcom (OCP: 1Gb, 10Gb, 25Gb, 100Gb, 200Gb)	10,4	2
Intel (OCP: 1Gb, 10Gb)	10,4	2
Mellanox (OCP: 25Gb, 100Gb)	10,4	2
NVIDIA (NIC: NDR400)	2,7	2
Broadcom (NIC: 25Gb, 100Gb, 200Gb)	2,7,3,9	2
Mellanox (NIC: 25Gb, 100Gb)	2,7	2
Mellanox (NIC: 25Gb, 100Gb, 200Gb, NDR400)	3,9	2
Marvell (HBA: FC32, FC64)	2,3,7,9	2
Emulex (HBA: FC32, FC64)	2,7,3,9	2
Foxconn (PERC H965E Adapter)	2,3,7,9	1
Foxconn (HBA465E)	2,3,7,9	1
NVidia BlueField-3 B3220	2,7	2

Table 80. RC 5: R1b+R2b+R3b+R4b+R5e

Card type	Slot priority	Maximum number of cards
NVIDIA (DPU: 200Gb)	2,7	2
NVIDIA (L4 GPU)	2,3,4,7,8,9	2
Foxconn (BOSS-N1)	6	2
Foxconn (PERC H965i, H975i FRNT,DCMHS)	Internal	1
Foxconn (PERC H965i, H365i, HBA465i,FRONT,DCMHS)	Internal	2
Broadcom (OCP: 1Gb)	10	1
Intel (OCP: 1Gb, 10Gb)	10	2
Broadcom (OCP:10Gb, 25Gb, 100Gb, 200Gb)	10	2
Mellanox (OCP: 25Gb, 100Gb)	10	2
Broadcom (NIC: 25Gb, 100Gb, 200Gb)	2,3,4,7,8,9	2
NVIDIA (NIC: NDR400)	2,3,4,7,8,9	2
Mellanox (NIC: 25Gb, 100Gb)	2,3,4,7,8,9	2
Emulex (HBA: FC32, FC64)	2,3,4,7,8,9	2
Marvell (HBA: FC32, FC64)	2,3,4,7,8,9	2
Foxconn (PERC H965E, HBA465E ADPT)	2,3,4,7,8,9	1
NVidia BlueField-3 B3220	2,7	2

Table 81. RC 7: R1a+R2b+R3a+R4b+R5a

Card type	Slot priority	Maximum number of cards
NVIDIA (L4 GPU)	3,9	2

Table 81. RC 7: R1a+R2b+R3a+R4b+R5a (continued)

Card type	Slot priority	Maximum number of cards
Foxconn (BOSS-N1)	6	1
Foxconn (Front PERC H965I, H365I, HBA465I)	Internal	1
Foxconn (Front PERC H975I)	Internal	2
Broadcom (OCP: 1Gb, 10Gb, 25Gb, 100Gb, 200Gb)	10	1
Intel (OCP: 1Gb, 10Gb)	10	1
Mellanox (OCP: 25Gb, 100Gb)	10	1
NVIDIA (NIC: NDR400)	3,9	2
Broadcom (NIC: 25Gb, 100Gb, 200Gb)	3,9	2
Mellanox (NIC: 25Gb, 100Gb)	3,9	2
Marvell (HBA: FC32, FC64)	1,2,3,4,5,7,8,9	8
Emulex (HBA: FC32, FC64)	1,2,3,4,5,7,8,9	8
Smart Modular (CXL:type3)	1,2,7,8	4
Foxconn (PERC H965E, HBA465E ADPT)	3,9	1

Table 82. RC 8: R1b+R3e+R5b

Card type	Slot priority	Maximum number of cards
Foxconn (PERC H965I, HBA465I ADPT)	7	1
Foxconn (PERC H965E, HBA465E ADPT)	2,7	1
NVIDIA (DPU: 200Gb)	2,7	2
NVIDIA (L4 GPU)	2,7	2
Foxconn (BOSS-N1)	6	1
Foxconn (Front PERC H965I, H975I)	Internal	2
Foxconn (Front PERC H365I, HBA465I)	Internal	1
Broadcom (OCP: 1Gb, 10Gb, 25Gb, 100Gb, 200Gb)	10,4	2
Intel (OCP: 1Gb, 10Gb)	10,4	2
Mellanox (OCP: 25Gb, 100Gb)	10,4	2
NVIDIA (NIC: NDR400)	2,7	2
Broadcom (NIC: 25Gb, 100Gb, 200Gb)	2,7	2
Marvell (HBA: FC32, FC64)	2,7	2
Emulex (HBA: FC32, FC64)	2,7	2
Mellanox (NIC: 25Gb, 100Gb)	2,7	2
Nvidia BlueField-3 B3220	2,7	2

Removing the rear expansion card risers

Prerequisites

1. Follow the safety guidelines listed in the [Safety instructions](#).
2. Follow the procedure listed in the [Before working inside your system](#).
3. [Remove the air shroud](#).
4. If applicable, disconnect the cables from the expansion card or HPM board.

Steps

1. For riser 1, riser 3, and riser 5:
 - a. Loosen the captive screws on the riser and system.
 - b. Press the blue release tab on the riser and holding the edges lift the expansion card riser from the connector on the HPM board.

NOTE: The numbers on the image do not depict the exact steps. The numbers are for representation of sequence.

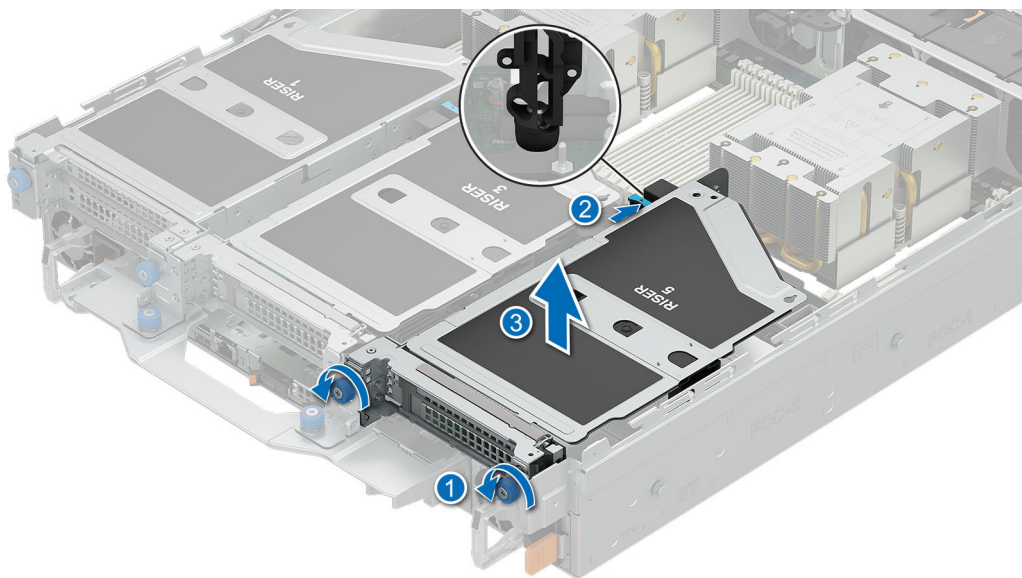

Figure 123. Removing the rear expansion card riser 5

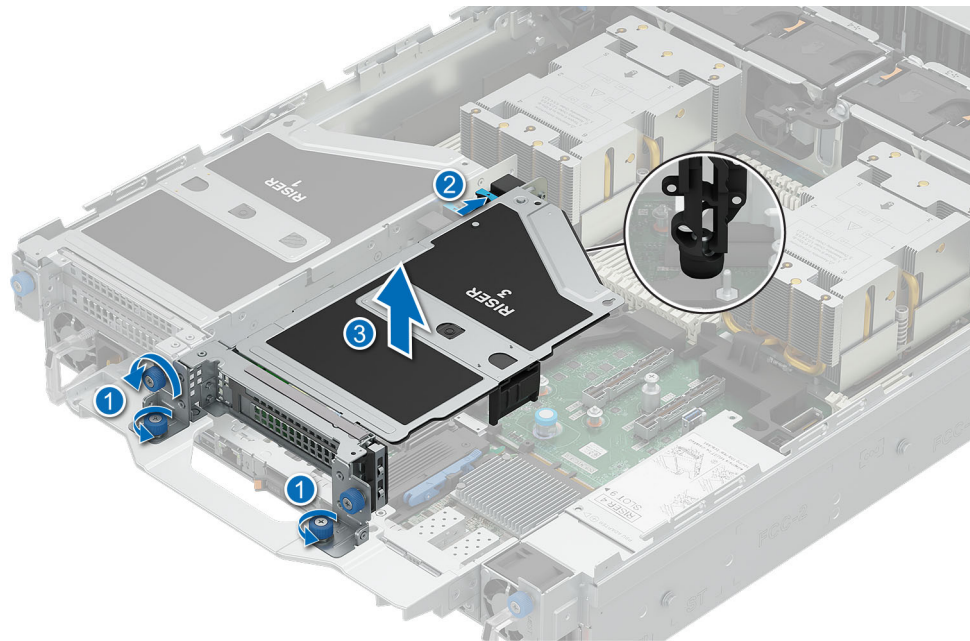

Figure 124. Removing the rear expansion card riser 3

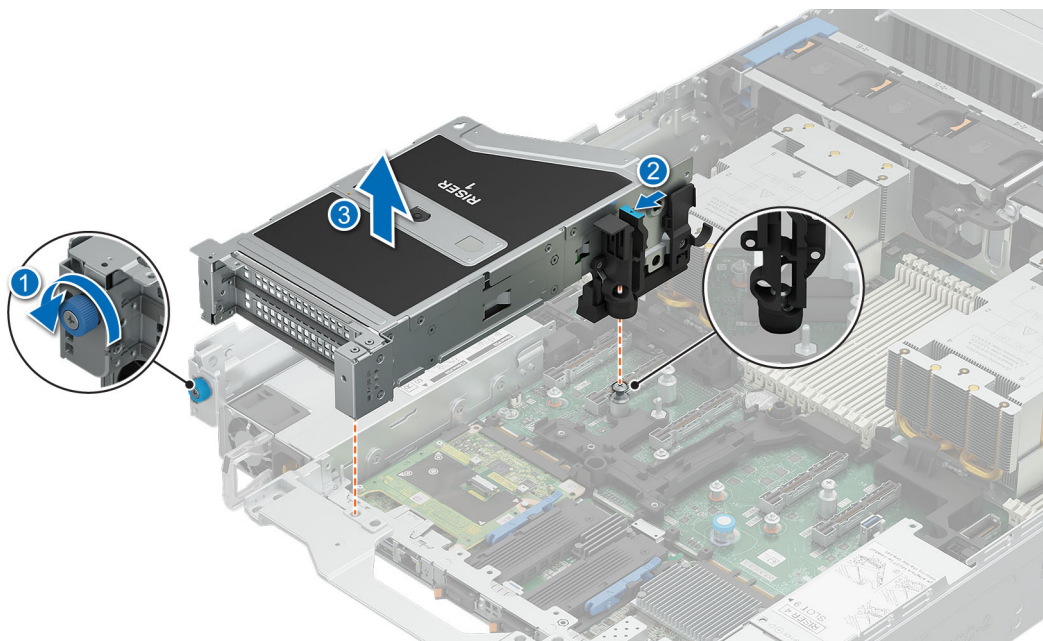

Figure 125. Removing the rear expansion card riser 1

2. For rear riser 2:
 - a. Slide the knob to unlock position.
 - b. Holding the edges lift the expansion card riser from the riser connector on the HPM board.

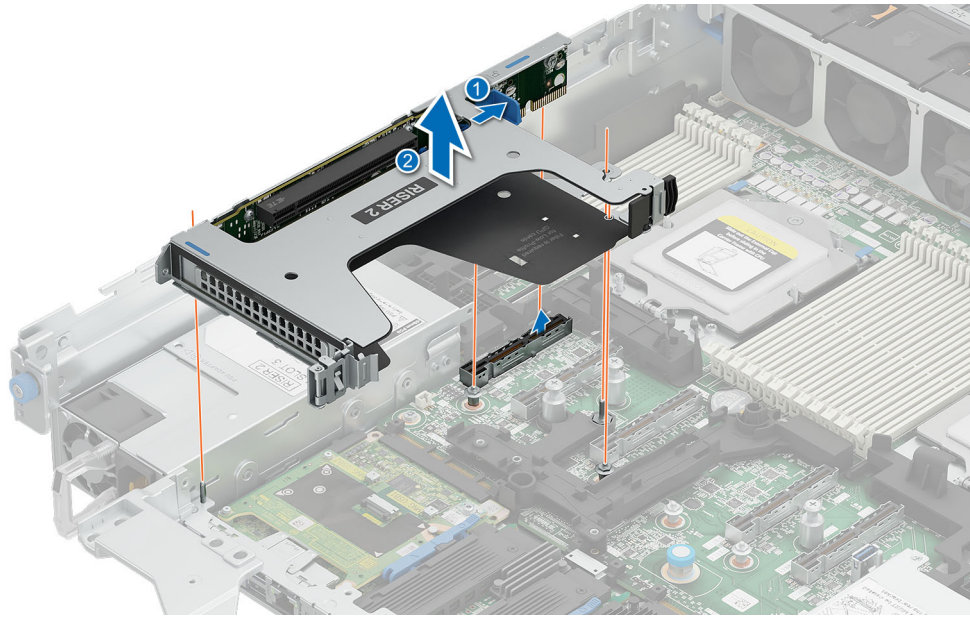

Figure 126. Removing the rear expansion card riser 2

3. For rear riser 4:
 - a. Pull and disconnect the riser cable from the HPM board.
 - b. Holding the edges lift the expansion card riser from the riser connector on the HPM board.

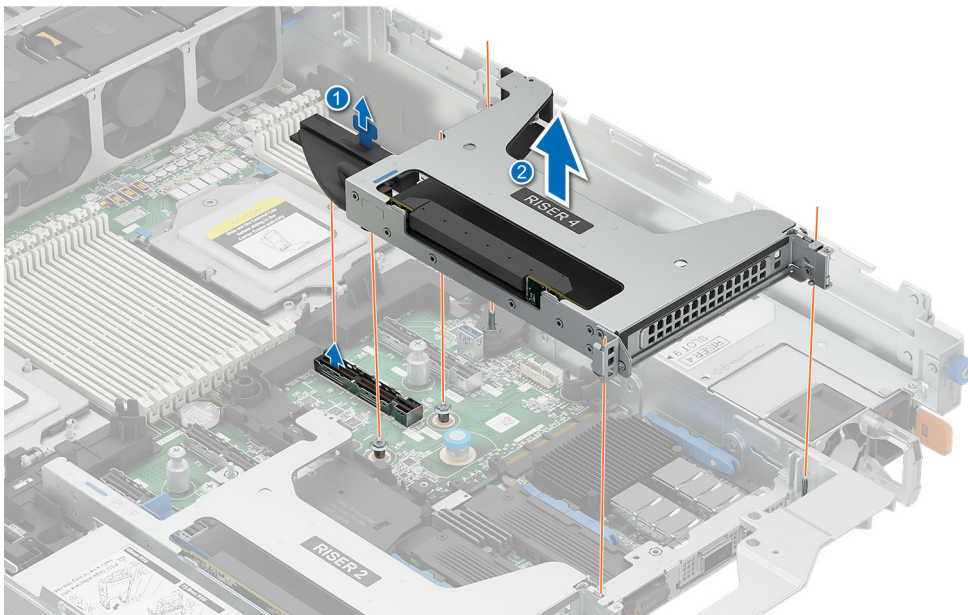

Figure 127. Removing the rear expansion card riser 4

Next steps

1. [Replace the rear expansion card risers.](#)

Installing the rear expansion card risers

Prerequisites

1. Follow the safety guidelines listed in the [Safety instructions](#).

2. Follow the procedure listed in the [Before working inside your system](#).
3. [Remove the air shroud](#).
4. If removed, [install the expansion cards into the rear expansion card risers](#).

i **NOTE:** Install riser 2 and riser 4 before installing riser 1, riser 3, and riser 5.

△ **CAUTION:** Do not install GPUs, network cards, or other PCIe devices on your system that are not validated and tested by Dell. Damage caused by unauthorized and invalidated hardware installation will null and void the system warranty.

Steps

1. For rear riser 4:
 - a. Holding the edges or the touch points, align the holes on the expansion card riser with the guides on the HPM board.
 - b. Lower the expansion card riser into place and press the touch points until the expansion card riser is fully seated on the HPM board.
 - c. Connect the riser cable connector to the HPM board.

i **NOTE:** The numbers on the image do not depict the exact steps. The numbers are for representation of sequence.

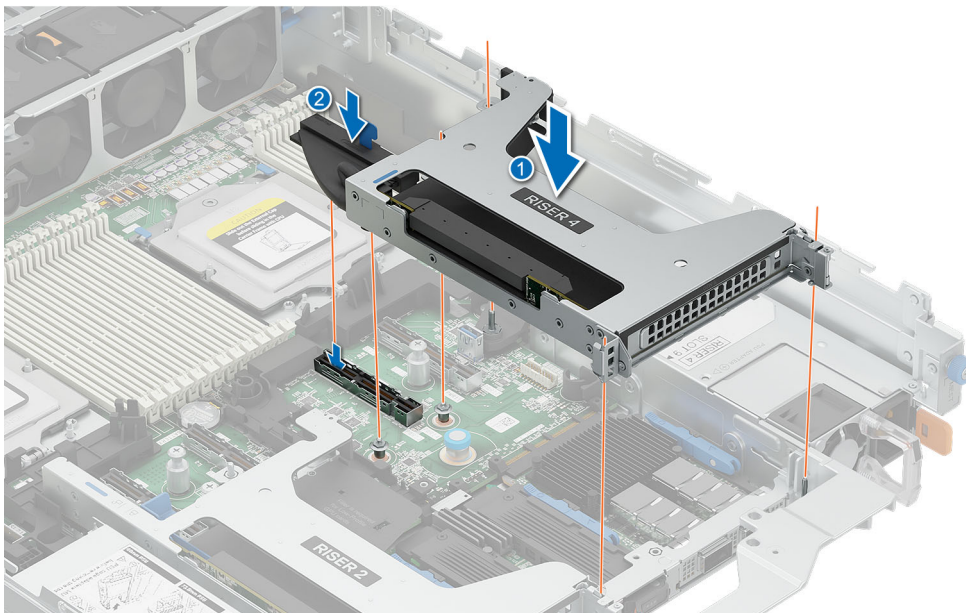

Figure 128. Installing the rear expansion card riser 4

2. For rear riser 2:
 - a. Holding the edges or the touch points, align the holes on the expansion card riser with the guides on the HPM board.
 - b. Lower the expansion card riser into place and press the touch points until the expansion card riser connector is fully seated on the HPM board connector.
 - c. Slide the knob into lock position.

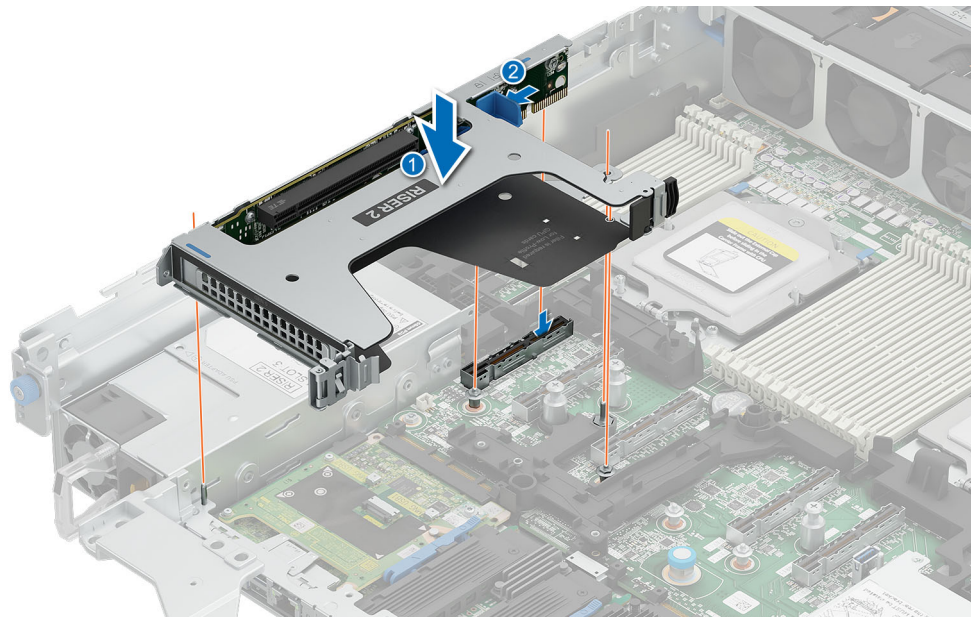

Figure 129. Installing the rear expansion card riser 2

3. For rear riser 1, riser 3, and riser 5:
 - a. Holding the edges or the touch points, align the holes on the expansion card riser with the guides on the HPM board.
 - b. Lower the expansion card riser into place and press the touch points until the expansion card riser connector is fully seated on the HPM board connector.
 - c. Tighten the captive screws on the risers and system if any.

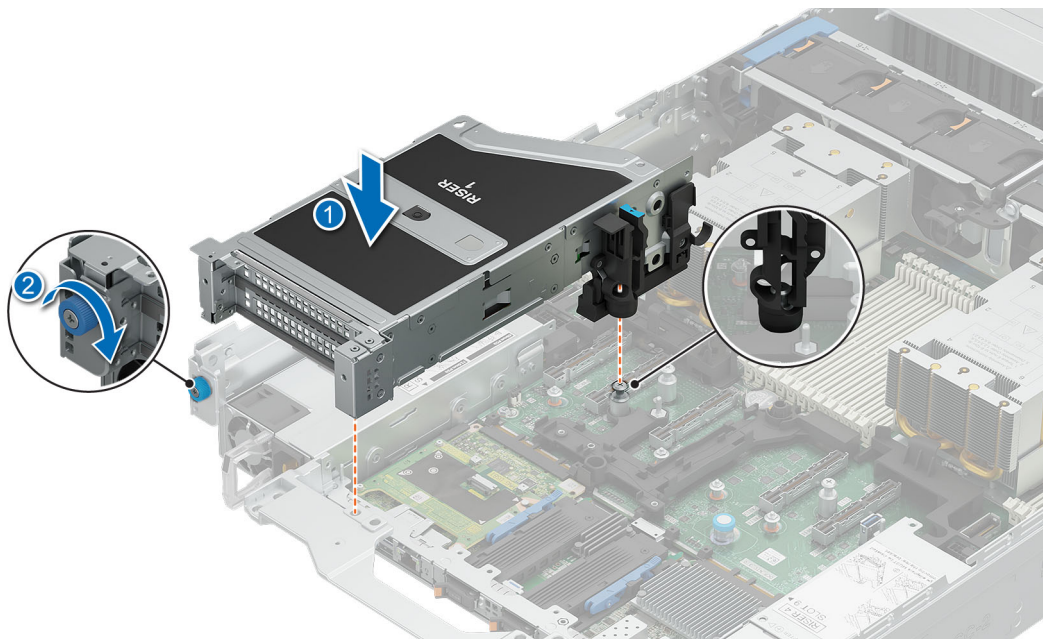

Figure 130. Installing the expansion card riser 1

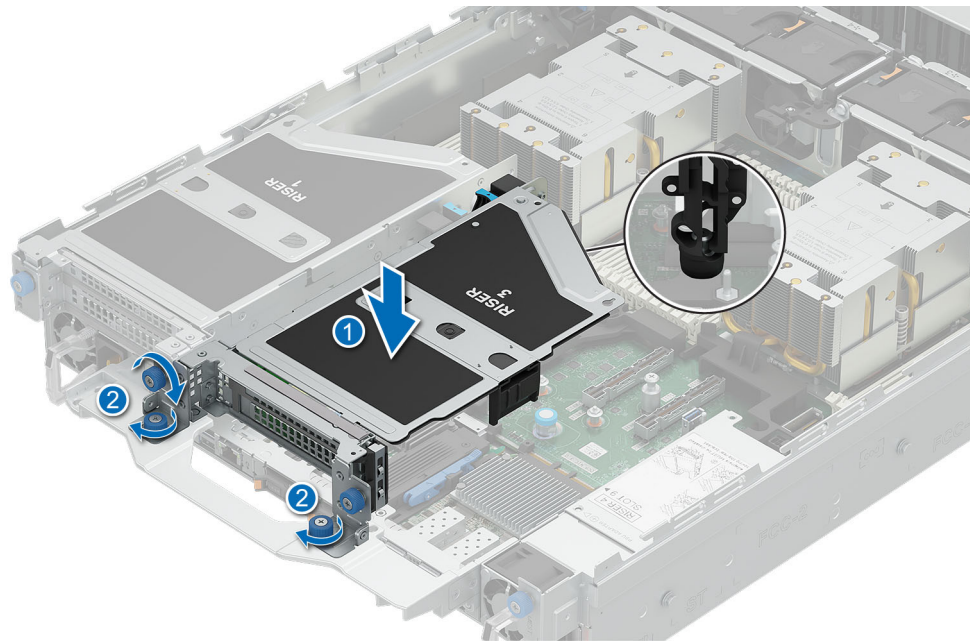

Figure 131. Installing the rear expansion card riser 3

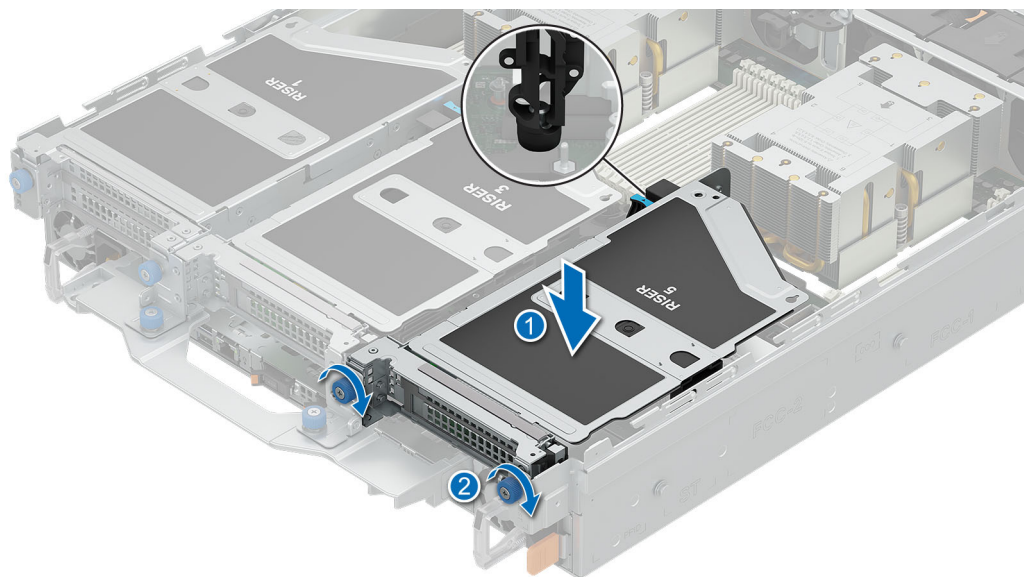

Figure 132. Installing the rear expansion card riser 5

Next steps

1. If required, reconnect the cables to the expansion card or HPM board.
2. [Install the air shroud.](#)
3. Follow the procedure listed in [After working inside your system.](#)

Removing the dual-width GPU

Prerequisites

1. Follow the safety guidelines listed in the [Safety instructions.](#)

2. Follow the procedure listed in the [Before working inside your system.](#)
3. If applicable, disconnect the cables from the expansion card or HPM board.

Steps

1. Lift the GPU shroud upwards and remove it from the system.

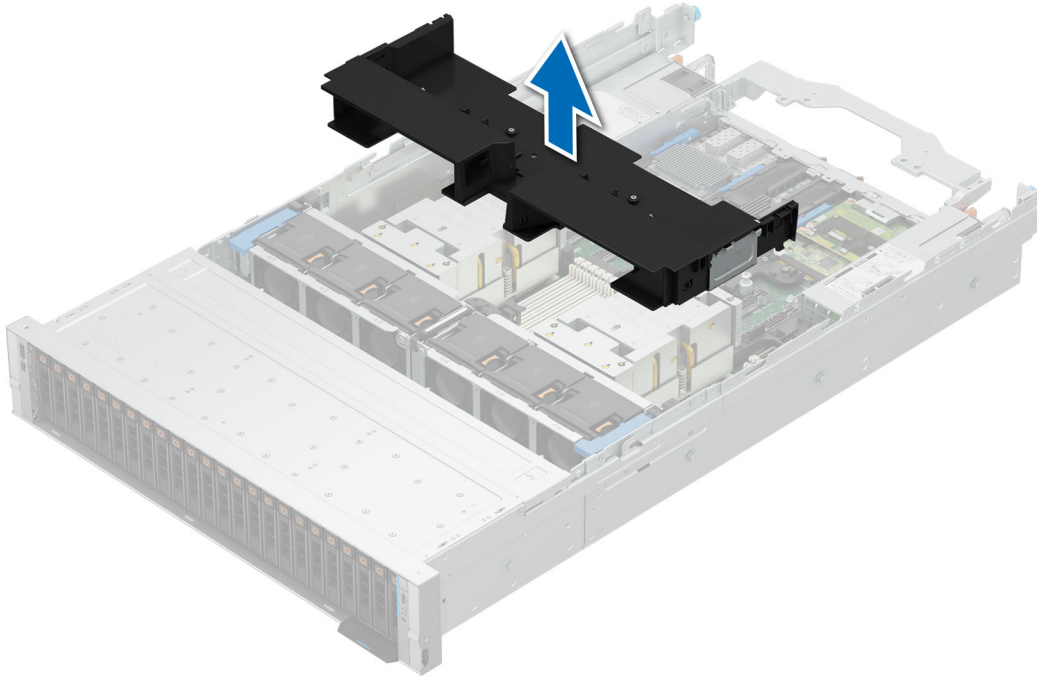

Figure 133. Removing the GPU air shroud

2. Loosen the captive screws and press the blue latch to release the riser 5 or riser 1 and remove it from the system.

i **NOTE:** The numbers on the image do not depict the exact steps. The numbers are for representation of sequence.

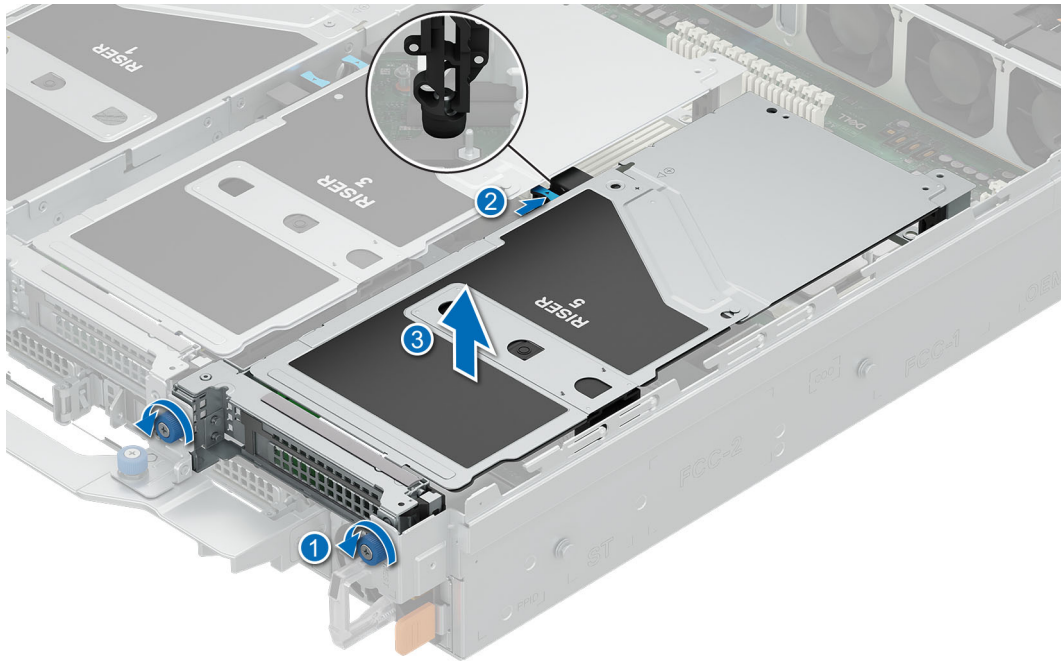

Figure 134. Removing the full-length riser 5

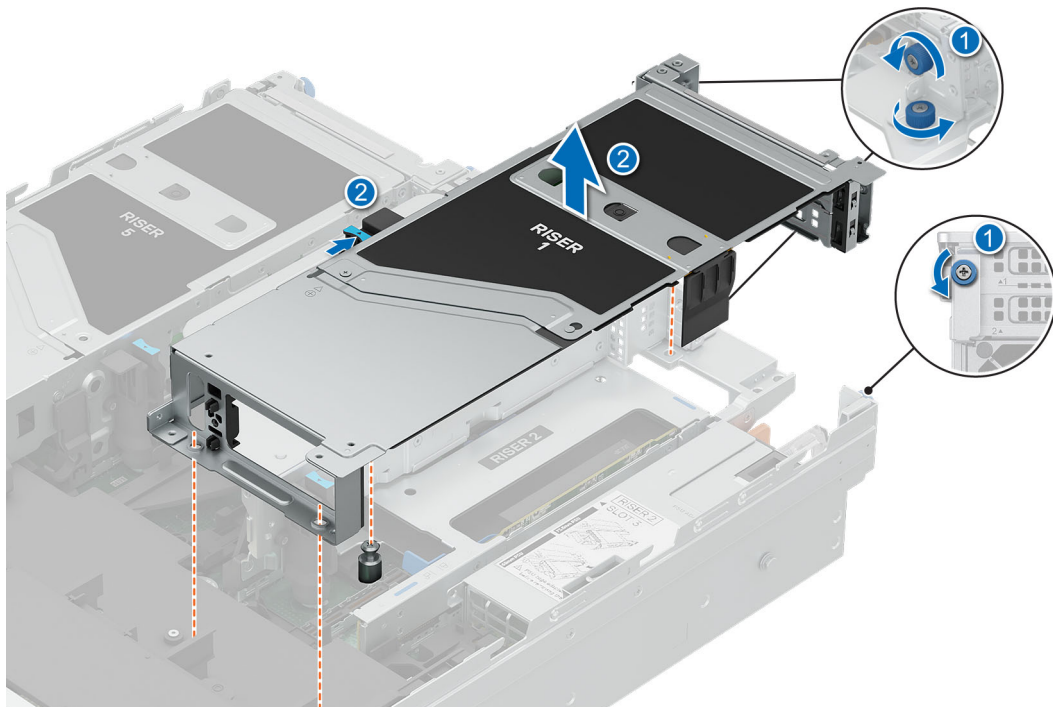

Figure 135. Removing the full-length riser 1

3. Push the GPU shroud top cover down until it clicks into place.

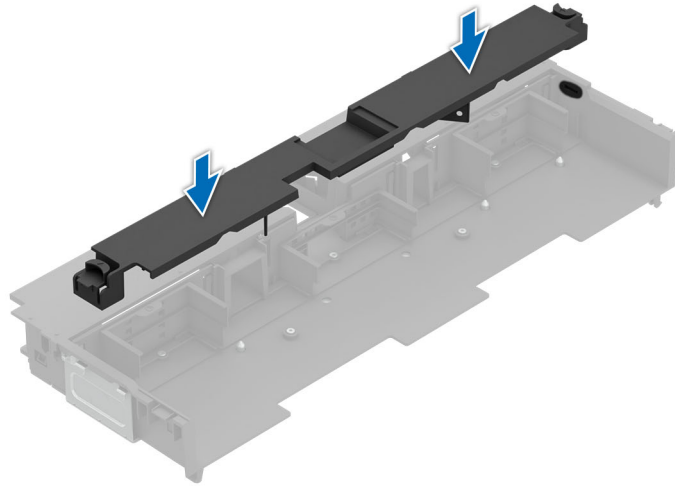

Figure 136. Installing the GPU shroud top cover

4. Lower down the GPU shroud fillers into the GPU shroud until it secures into place.

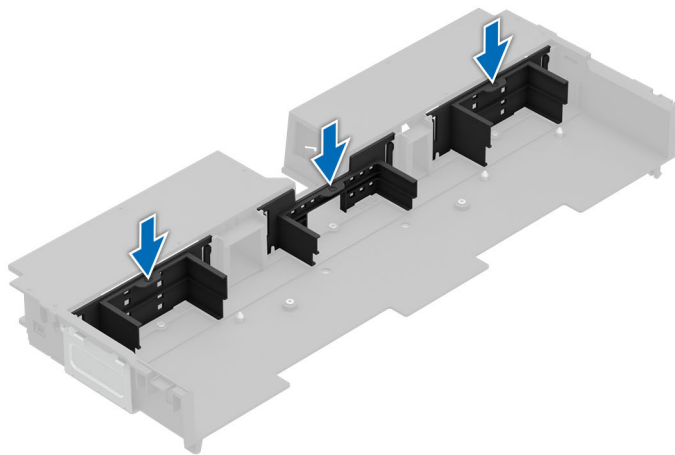

Figure 137. Installing the GPU shroud filler

Next steps

1. Replace the rear expansion card risers.

Installing the dual-width GPU

Prerequisites

1. Follow the safety guidelines listed in the [Safety instructions](#).
2. Follow the procedure listed in the [Before working inside your system](#).
3. [Install the expansion cards into the rear expansion card risers](#).

i **NOTE:** Install riser 2 and riser 4 before installing riser 1, riser 3, and riser 5.

△ CAUTION: Do not install GPUs, network cards, or other PCIe devices on your system that are not validated and tested by Dell. Damage caused by unauthorized and invalidated hardware installation will null and void the system warranty.

Steps

1. Press the two latches and remove the GPU shroud top cover.

i **NOTE:** The numbers on the image do not depict the exact steps. The numbers are for representation of sequence.

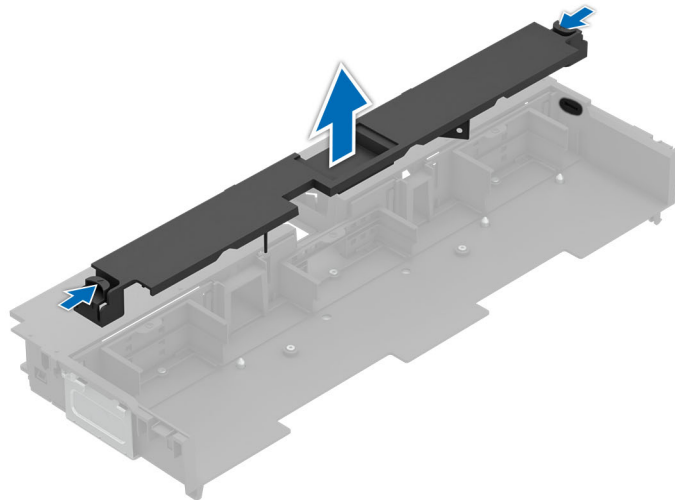

Figure 138. Removing the GPU shroud top cover

2. Lift and remove the GPU shroud fillers.

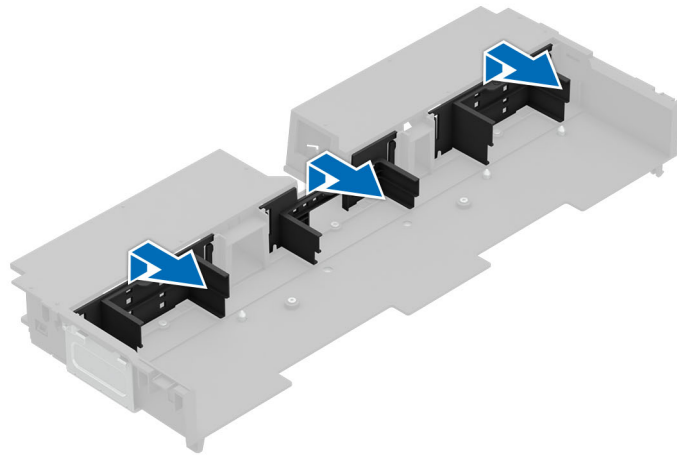

Figure 139. Removing the GPU shroud filler.

3. Lower the fan gantry towards the system and push the blue latches down to secure it in place.

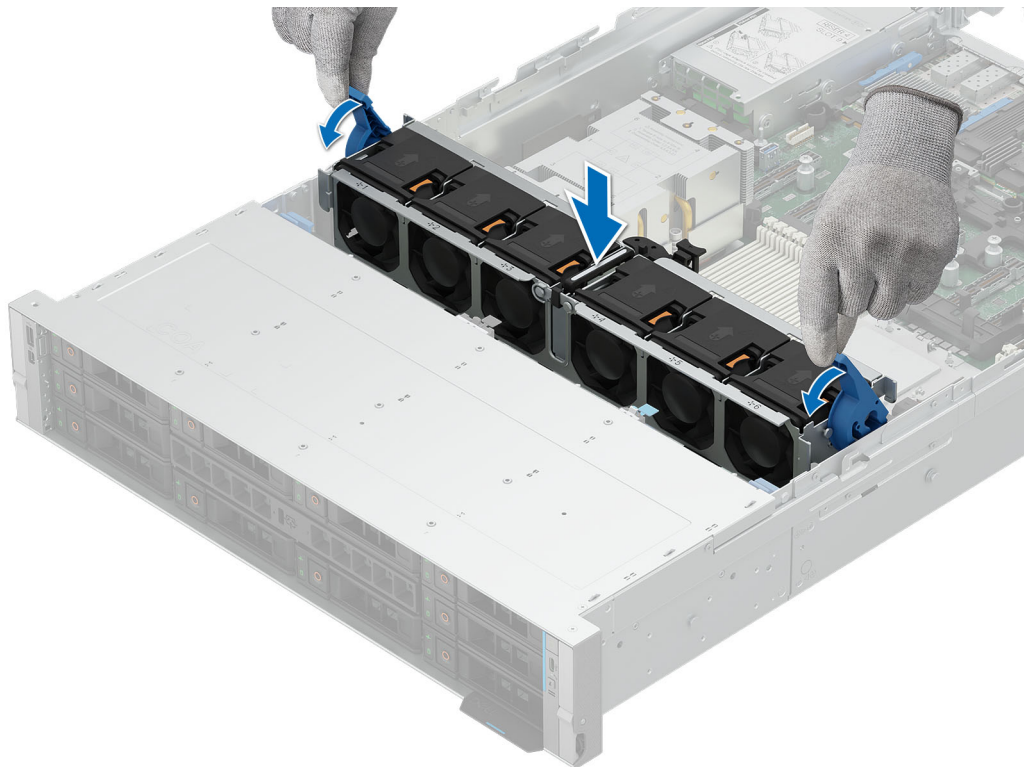

Figure 140. Installing the fan gantry

4. Align the GPU shroud on both side trenches of the system and push it down to secure it in place.

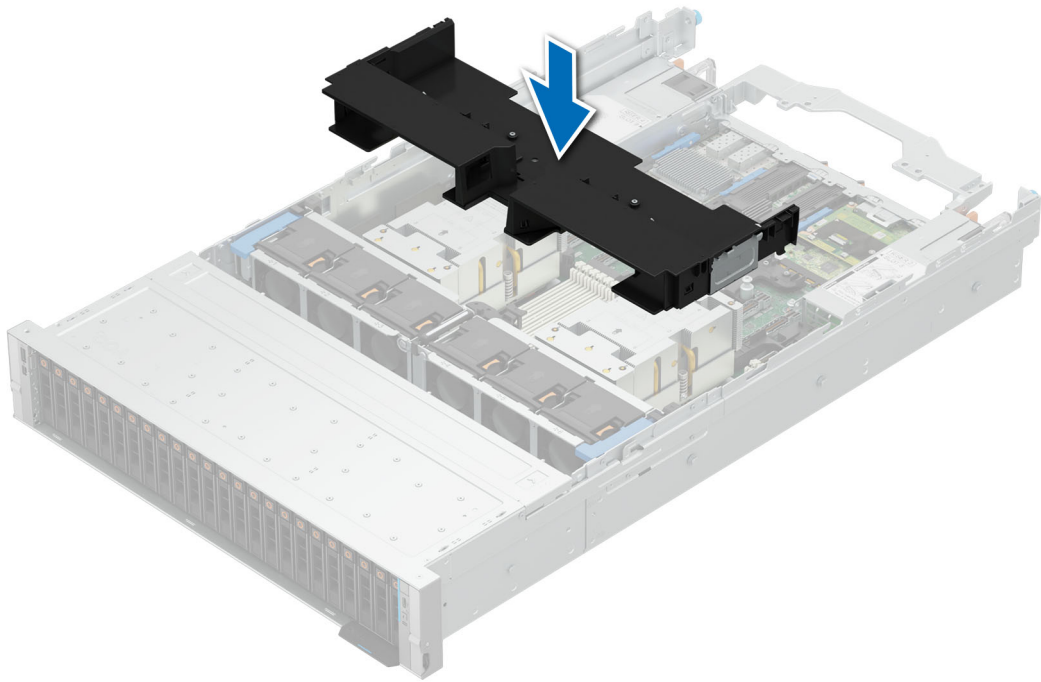

Figure 141. Installing the GPU shroud

5. Align the riser 1 or riser 5 with the guide pins on the chassis. Lower it down towards the chassis and tighten the captive screws to secure it in place.

NOTE: See [installing the expansion card from the expansion card riser section](#) for the GPU installation.

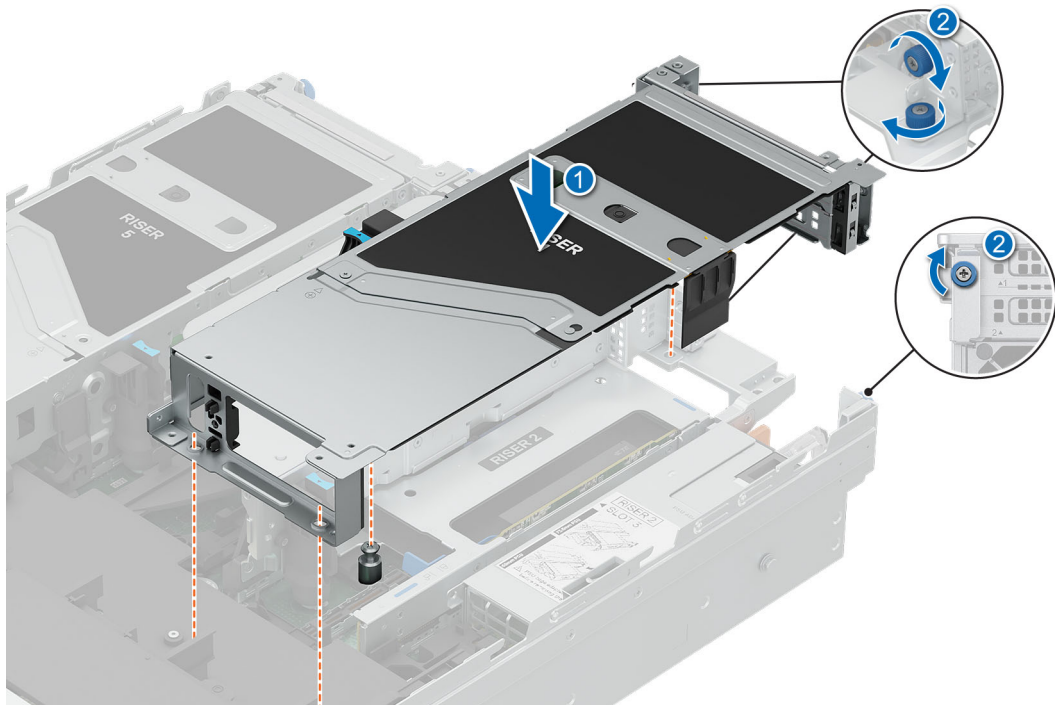

Figure 142. Installing the full-length riser 1

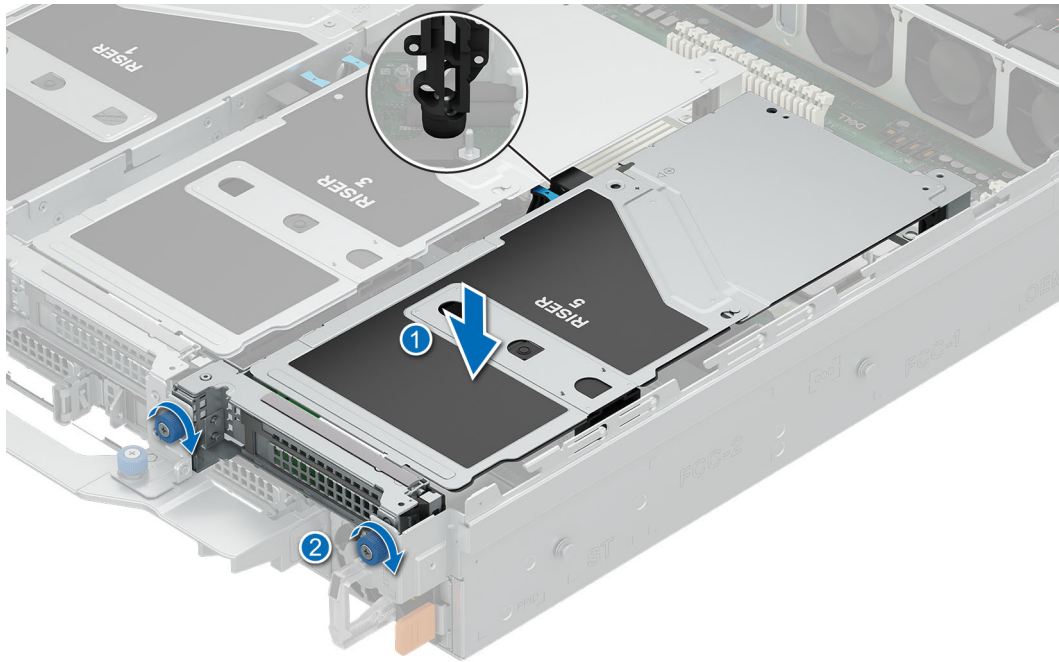

Figure 143. Installing the full-length riser 5

Next steps

1. If required, reconnect the cables to the expansion card or HPM board. See the [cable routing](#) section for more information.
2. Follow the procedure listed in [After working inside your system](#).

Removing an expansion card from the expansion card riser

Prerequisites

1. Follow the safety guidelines listed in the [Safety instructions](#).
2. Follow the procedure listed in [Before working inside your system](#).
3. If required, [remove the air shroud](#).
4. If applicable, disconnect the cables from the expansion card.
5. [Remove the rear expansion card riser](#).

Steps

1. Removal of the expansion card from riser 1a, 1a_DWFH, 1b, 3b, 3e, 3a, 5a, 5b, and 5e card:

NOTE: Steps to remove the expansion card from these risers are the same.

- a. Tilt the expansion card retention latch lock to open.
- b. Pull the card holder before removing the card from the riser.
- c. Hold the expansion card by the edges and pull the card from the riser.

NOTE: The numbers on the image do not depict the exact steps. The numbers are for representation of sequence.

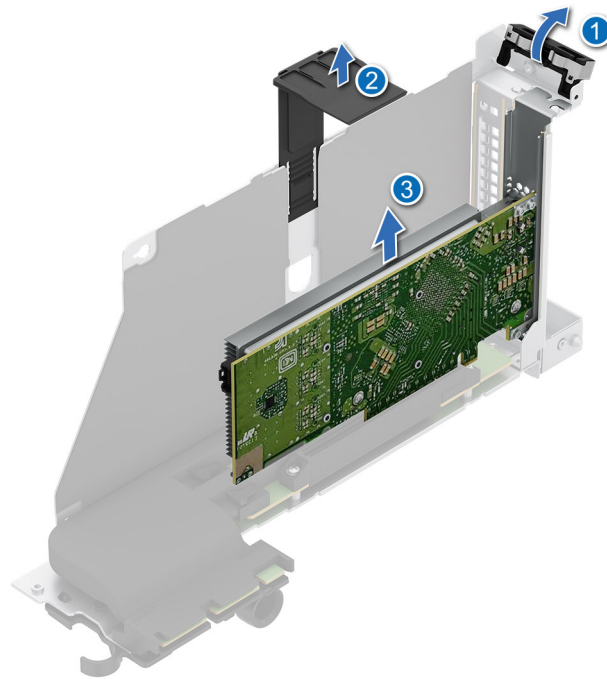

Figure 144. Removing low profile expansion card from the rear expansion card riser

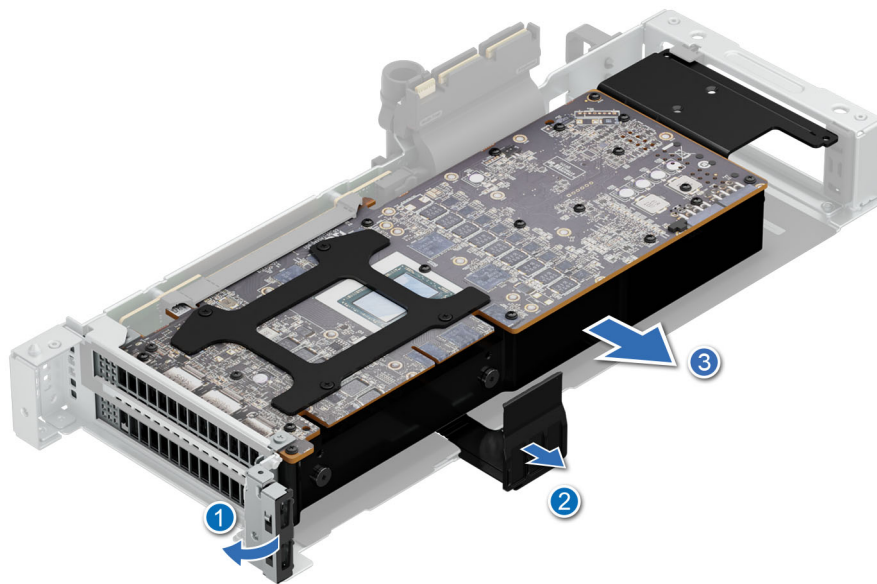

Figure 145. Removing the GPU card from riser 1a_DWFH

- d. If the expansion card is not going to be replaced on the riser, install a filler bracket and close the card holder on both ends of the riser.

i **NOTE:** You must install a filler bracket over an empty expansion card slot to maintain Federal Communications Commission (FCC) certification of the system. The filler bracket also keeps dust and dirt out of the system and aids in proper cooling and airflow inside the system.

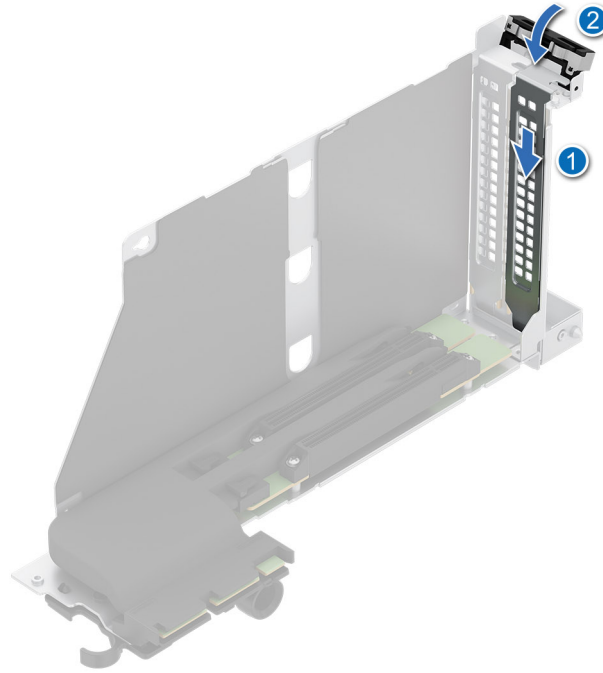

Figure 146. Installing the filler bracket

2. OCP NIC card from riser 3e:
 - a. Press and remove the cover latch from the riser.

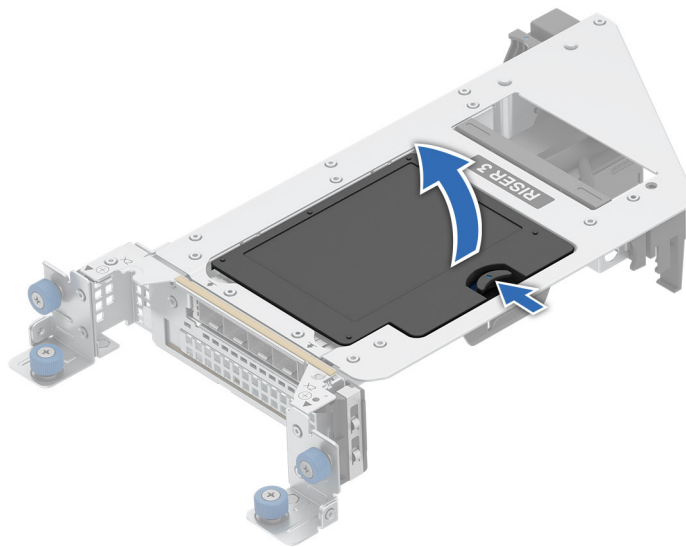

Figure 147. Removing an OCP NIC cover from the riser 3e

- b. Open the blue latch to disengage the OCP NIC card.
- c. Push and slide out the OCP NIC card from the rear end of the riser.

NOTE: The numbers on the image do not depict the exact steps. The numbers are for representation of sequence.

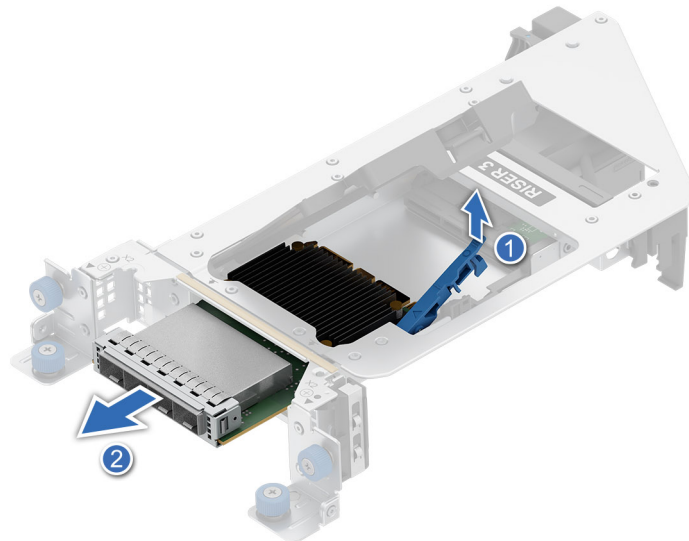

Figure 148. Removing an OCP NIC card from the riser 3e

3. Removing the expansion card from riser 2a, 2b, and 4a:

i NOTE: Steps to remove the expansion card from these risers are the same.

- a. Tilt the card holder on both ends of the riser.
- b. Hold the expansion card by the edges and pull the card from the riser.

i NOTE: The numbers on the image do not depict the exact steps. The numbers are for representation of sequence.

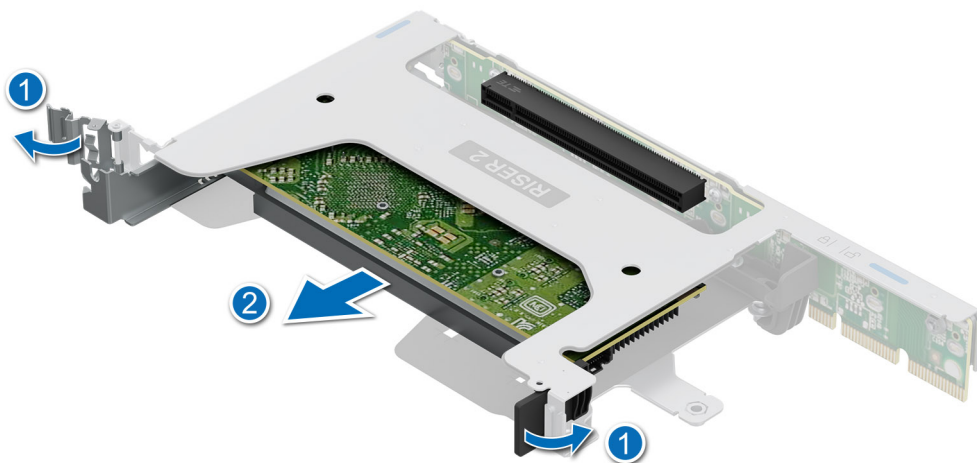

Figure 149. Removing expansion card from the riser

- c. If the expansion card is not going to be replaced on the riser, install a filler bracket and close the card holder on both ends of the riser.

i NOTE: You must install a filler bracket over an empty expansion card slot to maintain Federal Communications Commission (FCC) certification of the system. The filler bracket also keeps dust and dirt out of the system and aids in proper cooling and airflow inside the system.

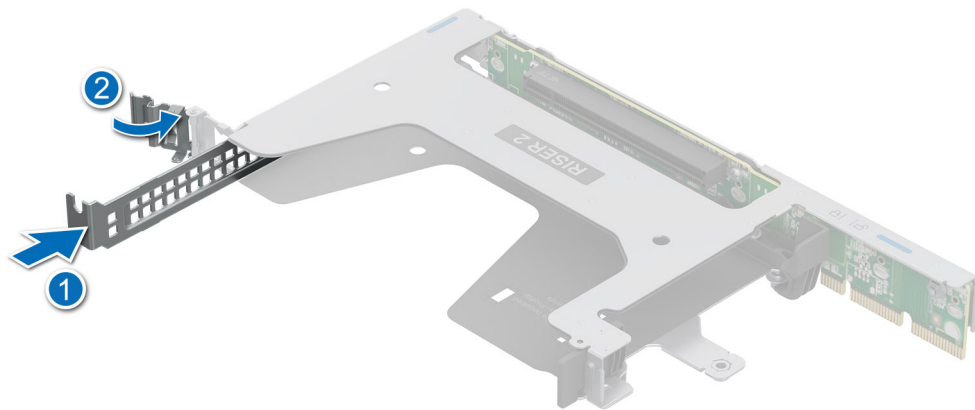

Figure 150. Installing the filler bracket

4. To remove the low-profile expansion card from riser 4b:
 - a. Lift the latches and slide out the card holder from the riser.

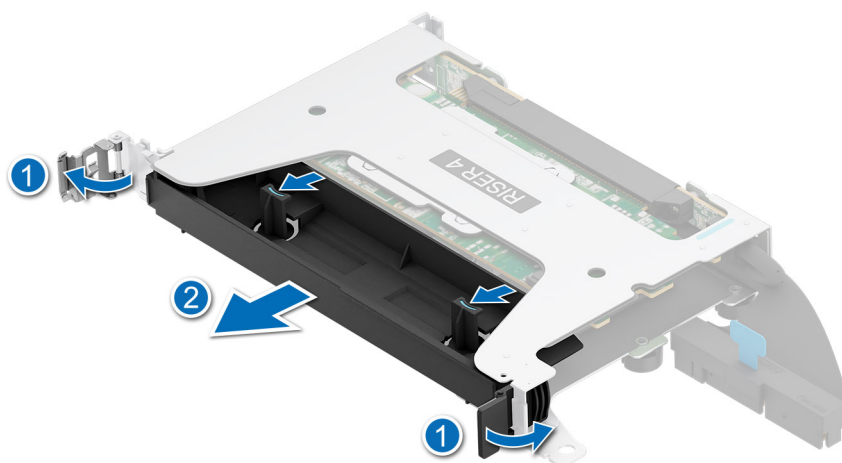

Figure 151. Removing card holder from the riser 4b

- b. Tilt the card holder on both ends of the riser.
- c. Hold the expansion card by the edges and pull the card from the riser.

NOTE: The numbers on the image do not depict the exact steps. The numbers are for representation of sequence.



Figure 152. Removing low-profile expansion card from the riser 4b

- d. If the expansion card is not going to be replaced on the riser, install a filler bracket or PCIe blank and close the card holder on both ends of the riser.
- i **NOTE:** A PCIe blank must be put in riser 4b to balance the airflow for the rear OCP NIC card.
 - i **NOTE:** You must install a filler bracket over an empty expansion card slot to maintain Federal Communications Commission (FCC) certification of the system. The filler bracket also keeps dust and dirt out of the system and aids in proper cooling and airflow inside the system.

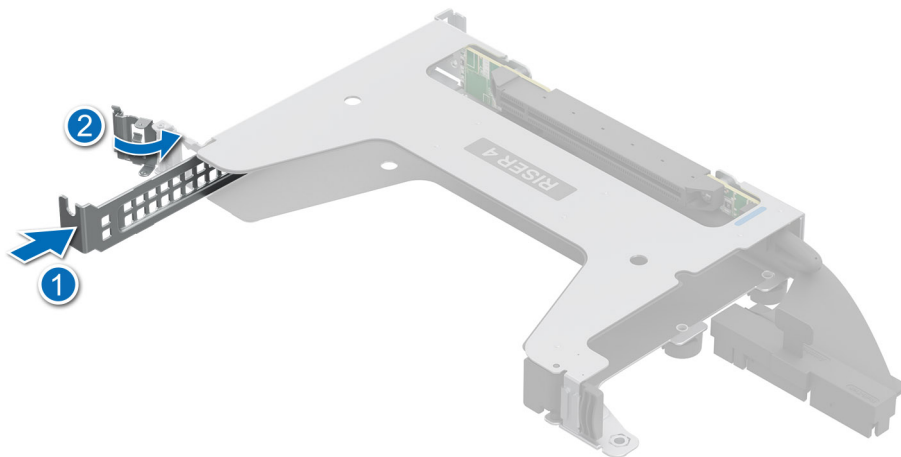

Figure 153. Installing the filler bracket

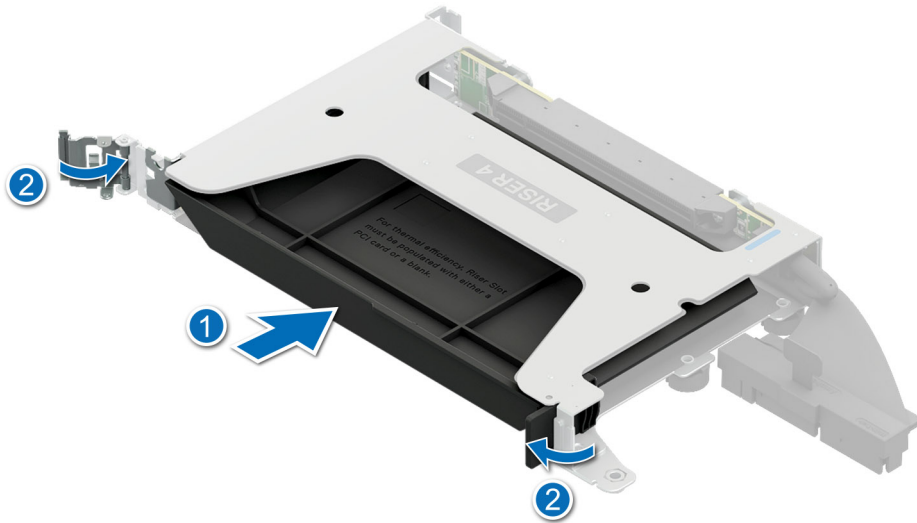

Figure 154. Installing the PCIe blank

Next steps

1. If applicable, [install an expansion card into the expansion card riser](#).

Installing an expansion card into the expansion card riser

Prerequisites

1. Follow the safety guidelines listed in the [Safety instructions](#).
2. Follow the procedure listed in [Before working inside your system](#).
3. If required, [remove the air shroud](#).
4. If applicable, disconnect the cables from the expansion card.
5. [Remove the rear expansion card riser](#).
6. If installing a new expansion card, unpack it and prepare the card for installation.

i **NOTE:** For instructions, see the documentation accompanying the card.

△ CAUTION: Do not install GPUs, network cards, or other PCIe devices on your system that are not validated and tested by Dell. Damage caused by unauthorized and invalidated hardware installation will null and void the system warranty.

Steps

1. Installing an expansion card into riser 4b:
 - a. Tilt the card holder on both ends and slide out the filler bracket or PCIe blank from the riser.

i **NOTE:** Store the filler bracket or PCIe blank for future use. Filler bracket or PCIe blank must be installed in empty expansion card slots to maintain Federal Communications Commission (FCC) certification of the system. The blank also keep dust and dirt out of the system and aid in proper cooling and airflow inside the system.

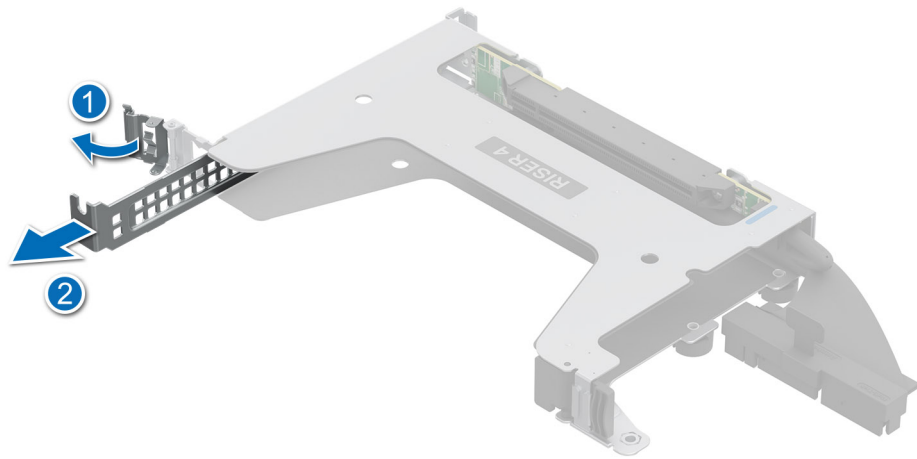

Figure 155. Removing the filler bracket

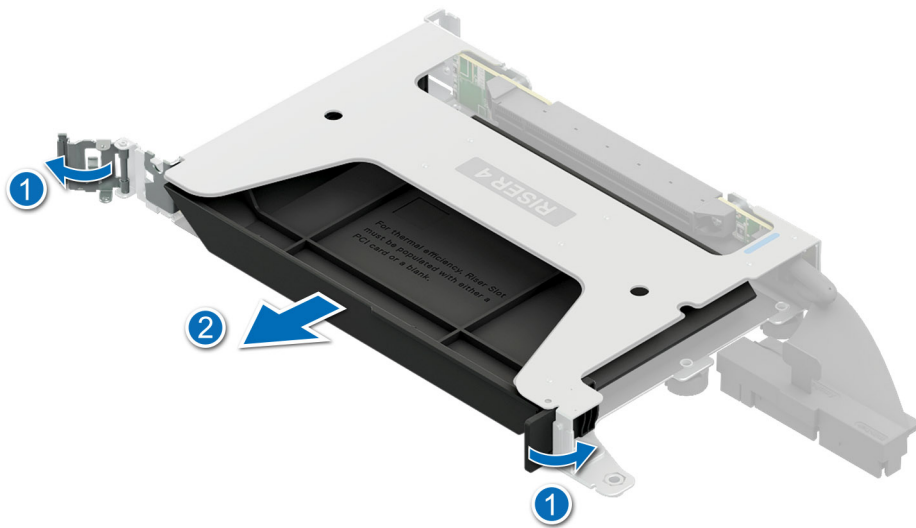

Figure 156. Removing the PCIe blank

- b. Hold the card by edges, and align the card with the connector on the riser.
- c. Insert the card firmly into the expansion card connector until seated.

NOTE: The numbers on the image do not depict the exact steps. The numbers are for representation of sequence.



Figure 157. Installing an expansion card into the riser 4b

- d. Align and slide the card holder guides into the slots on the riser until seated.
- e. Close the card holder on both ends of the riser.

NOTE: The numbers on the image do not depict the exact steps. The numbers are for representation of sequence.

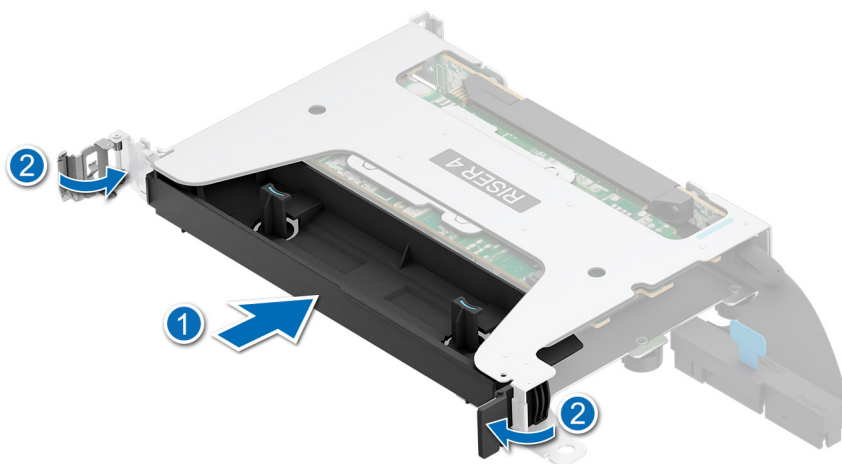

Figure 158. Installing expansion card into the riser 4b

- 2. Installing an expansion card into riser 2a, 2b, and 4a:

NOTE: Steps to install the expansion card into these risers are the same.

- a. Tilt the card holder on both ends and slide out the filler bracket from the riser.

NOTE: Store the filler bracket for future use. The filler bracket must be installed in empty expansion card slots to maintain Federal Communications Commission (FCC) certification of the system. The blank also keep dust and dirt out of the system and aid in proper cooling and airflow inside the system.

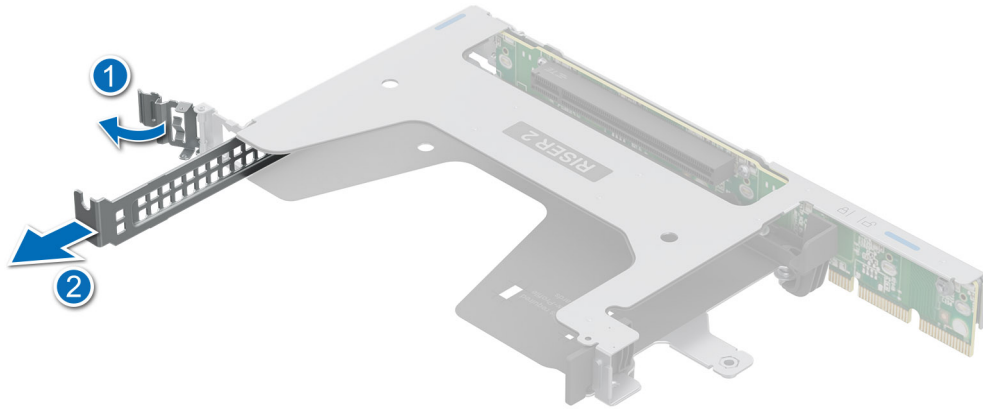

Figure 159. Removing the filler bracket

- b. Hold the card by edges, and align the card with the connector on the riser.
- c. Insert the card firmly into the expansion card connector until seated.
- d. Close the card holder on both ends of the riser.

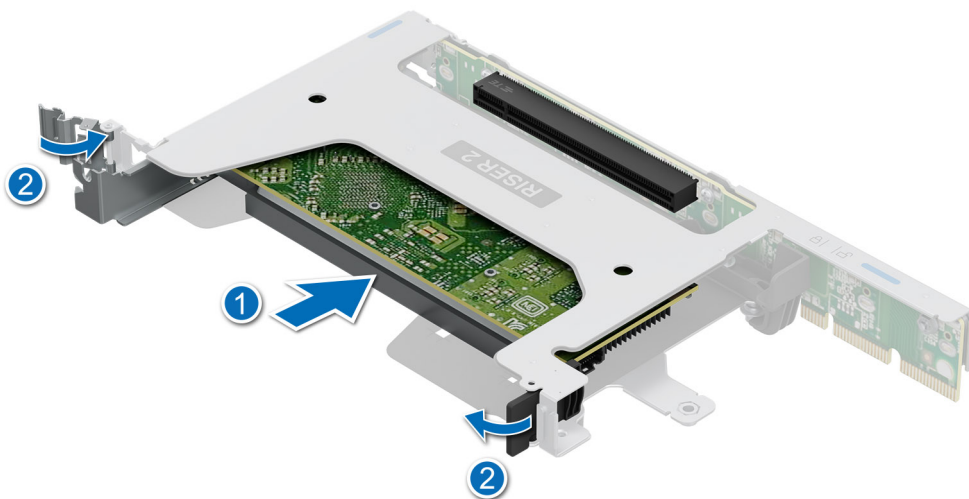

Figure 160. Installing expansion card into the riser 2

- e. Align and press the card holder into the slot on the riser until seated.
3. Installing an expansion card into riser 1a, 1a_DWFH, 1b, 3b, 3e, 3a, 5a, 5b, and 5e card:

i **NOTE:** Steps to install the expansion card into these risers are the same.

- a. Tilt the card holder and slide out the filler bracket from the riser.

i **NOTE:** Store the filler bracket for future use. The filler bracket must be installed in empty expansion card slots to maintain Federal Communications Commission (FCC) certification of the system. The blank also keep dust and dirt out of the system and aid in proper cooling and airflow inside the system.

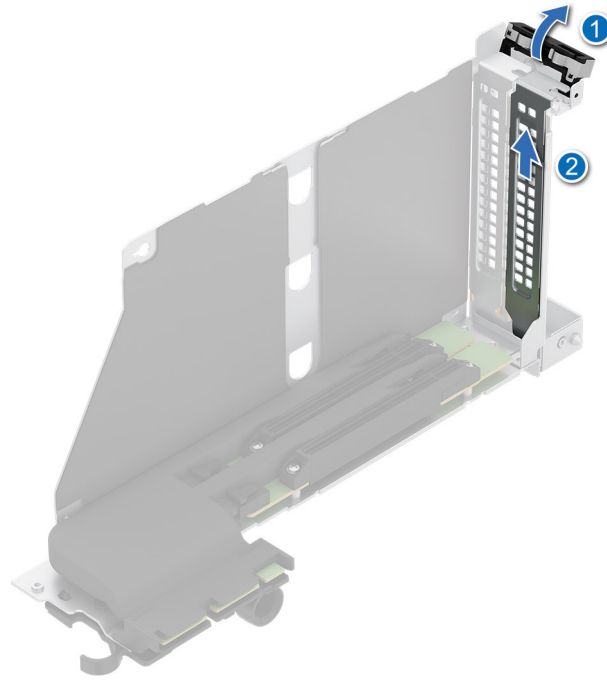

Figure 161. Removing the filler bracket

- b. Tilt the expansion card retention latch lock to open.
- c. Hold the card by edges, and align the card with the connector on the riser.
- d. Insert the card firmly into the expansion card connector until seated.
- e. Tilt the expansion card retention latch to close.
- f. Push the card holder to hold the card in the riser.

i **NOTE:** The numbers on the image do not depict the exact steps. The numbers are for representation of sequence.

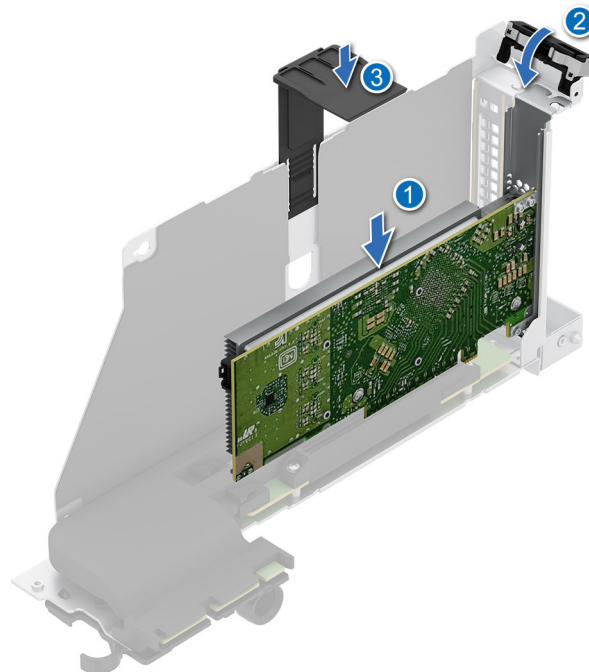

Figure 162. Installing a low-profile expansion card into the riser

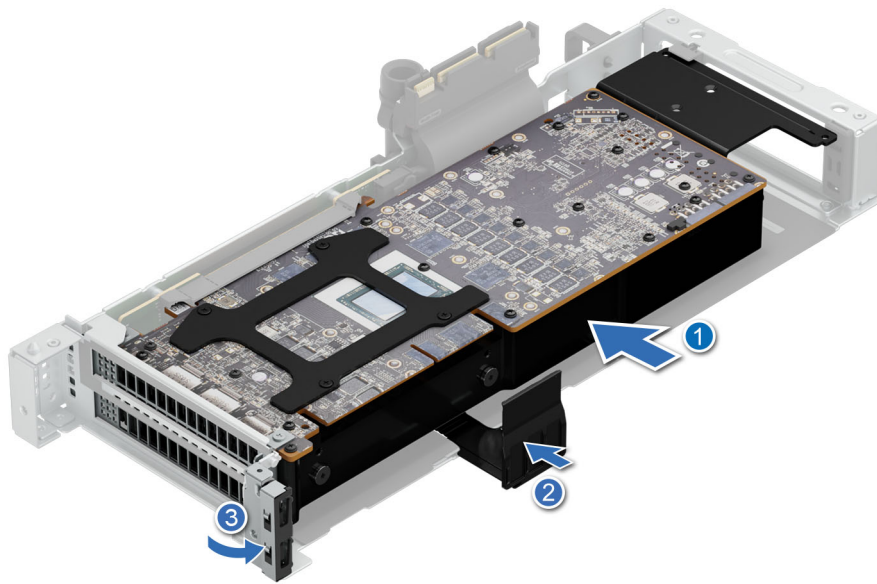

Figure 163. Installing the GPU into riser 1a_DWFH

4. OCP NIC card into riser 3e:
 - a. Open the blue latch on the riser.
 - b. Slide the OCP NIC card into the riser slot.
 - c. Push until the OCP NIC card is connected to the connector on the riser.
 - d. Close the blue latch to lock the OCP NIC card to the riser.

NOTE: The numbers on the image do not depict the exact steps. The numbers are for representation of sequence.

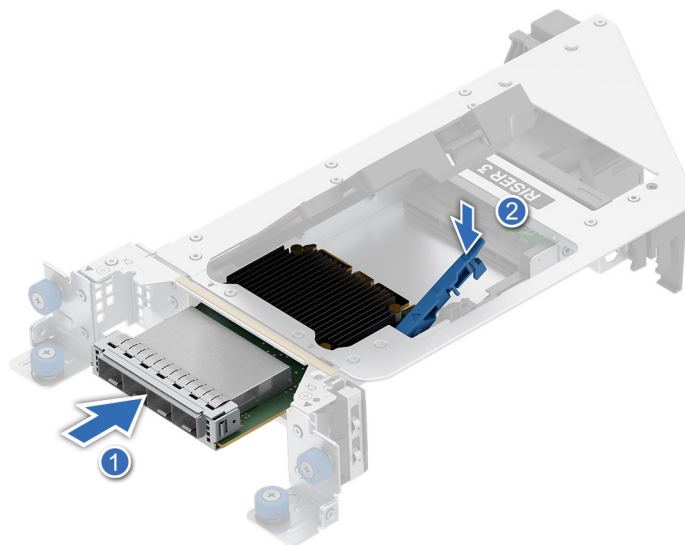

Figure 164. Installing an OCP NIC card into the riser 3e

- e. Align and insert the cover latch into the riser.

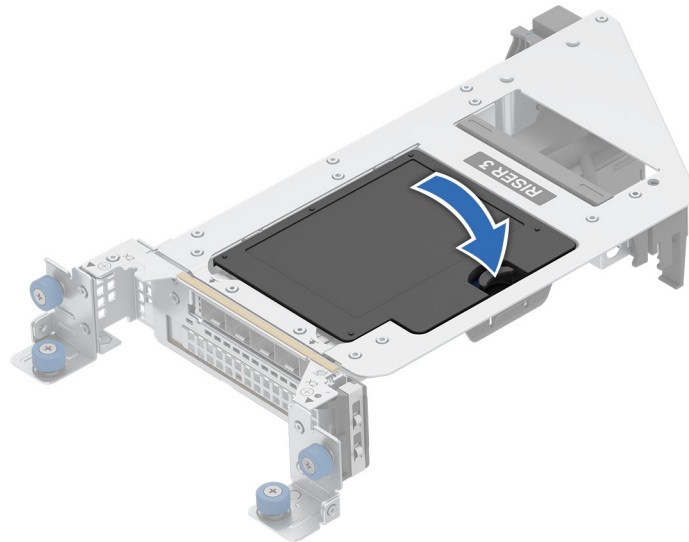

Figure 165. Installing an OCP NIC cover into the riser 3e

Next steps

1. If applicable, connect the cables to the expansion card.
2. [Install the rear expansion card risers.](#)
3. If removed, [install the air shroud.](#)
4. Follow the procedure listed in the [After working inside your system.](#)
5. Install any device drivers required for the card as described in the documentation for the card.

Removing the expansion card riser blanks

Prerequisites

1. Follow the safety guidelines listed in the [Safety instructions.](#)
2. Follow the procedure listed in the [Before working inside your system.](#)

Steps

1. Loosen the captive screws on the riser blanks and on the system chassis.
2. Holding the edges, lift the expansion card riser blanks out of the system.

NOTE: The numbers on the image do not depict the exact steps. The numbers are for representation of sequence.

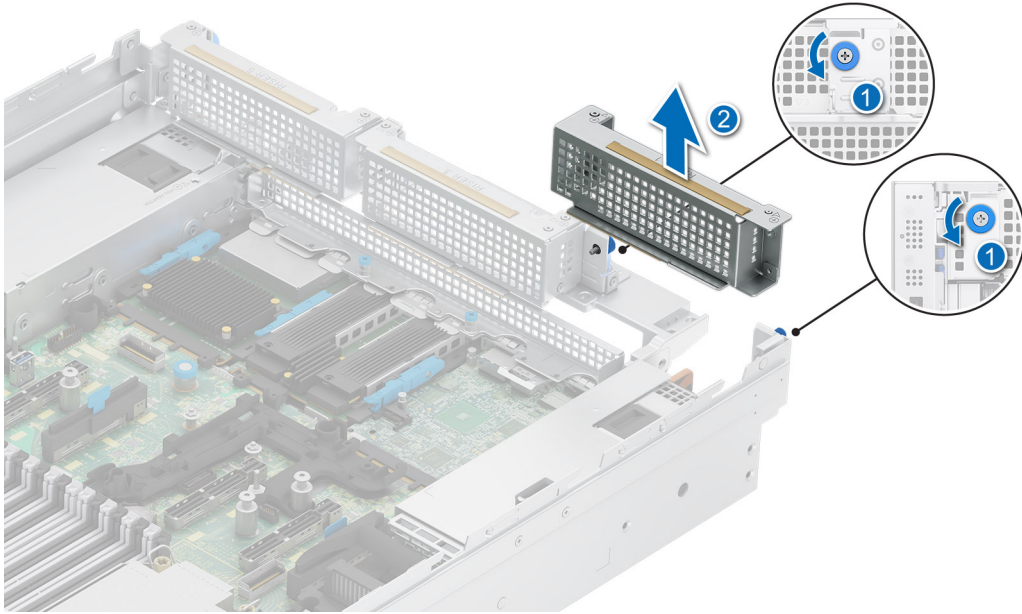

Figure 166. Removing the rear expansion card riser 1 blank

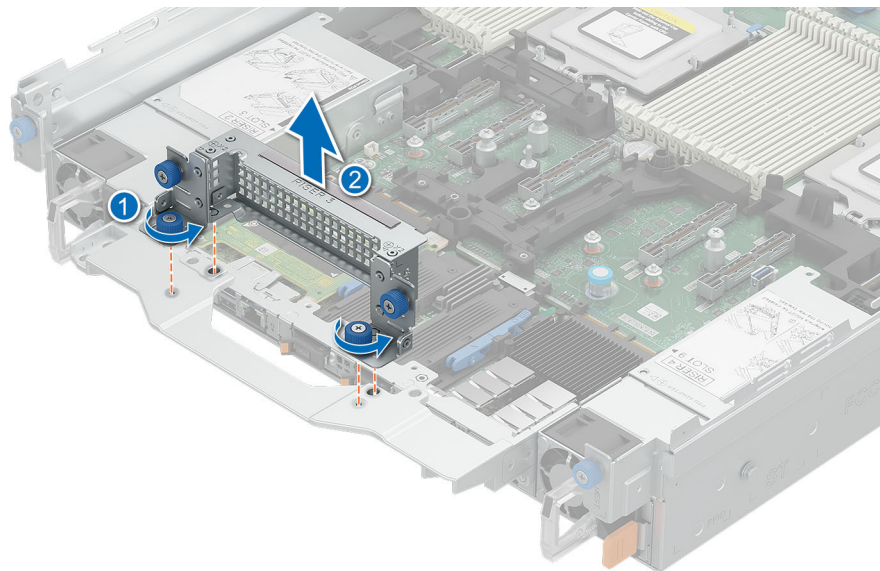

Figure 167. Removing the rear expansion card riser 3 blank

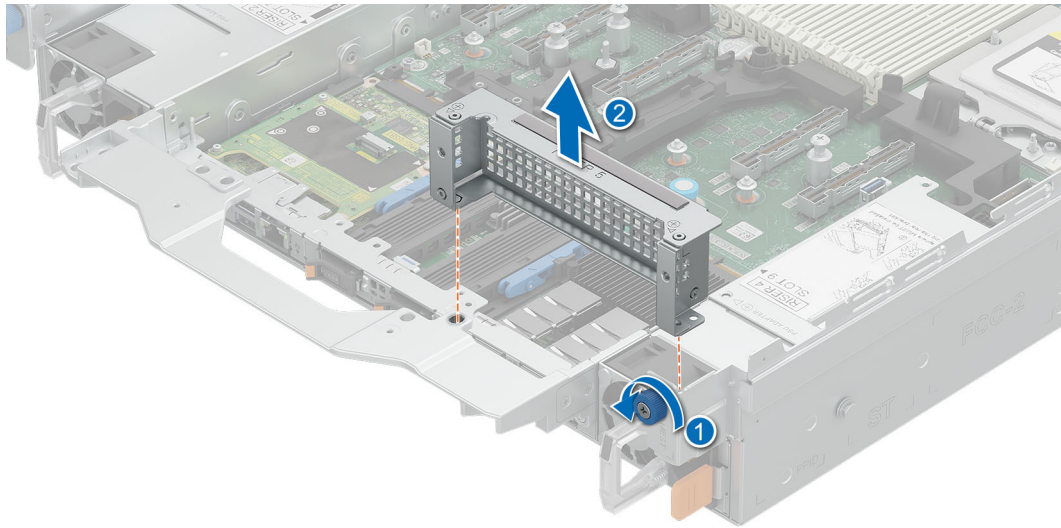

Figure 168. Removing the rear expansion card riser 5 blank

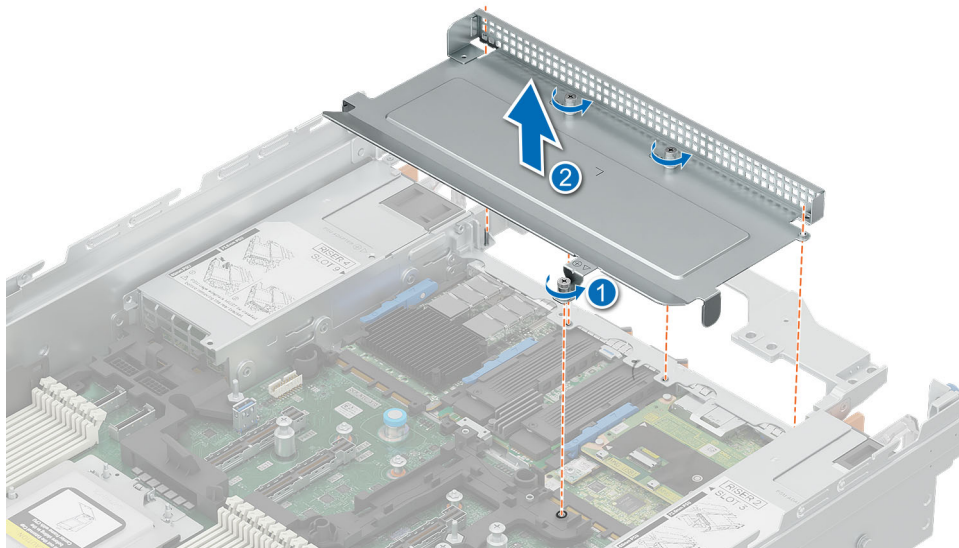

Figure 169. Removing the expansion card riser 4 and riser 2 blank

Next steps

1. Replace the rear expansion card riser blanks.

Installing the expansion card riser blanks

Prerequisites

1. Follow the safety guidelines listed in the [Safety instructions](#).
2. Follow the procedure listed in the [Before working inside your system](#).

Steps

1. Holding the edges, align the holes on the expansion card riser blanks with the guides on the system.
2. Lower the expansion card riser blanks into place.

3. Tighten the captive screws on the risers and system.

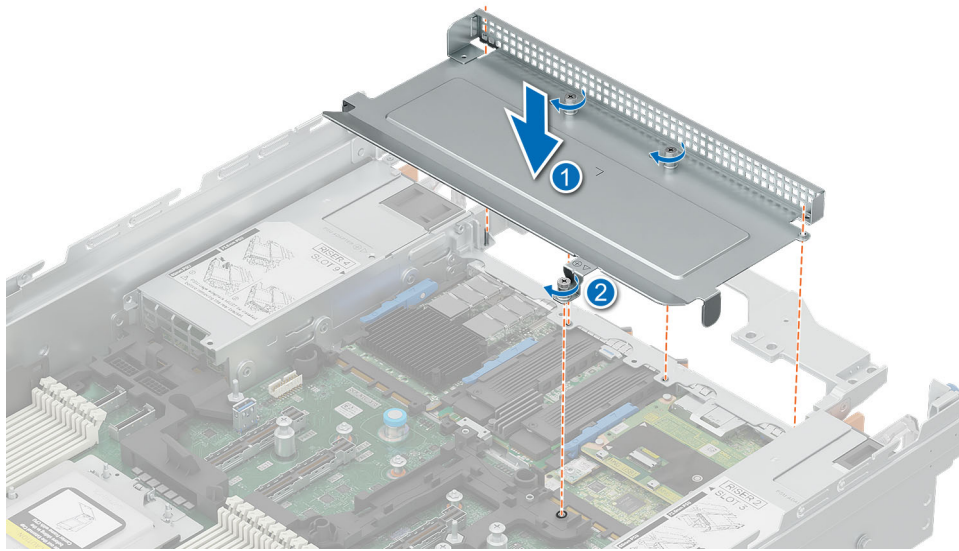

Figure 170. Installing the rear expansion card riser 4 and riser 2 blank

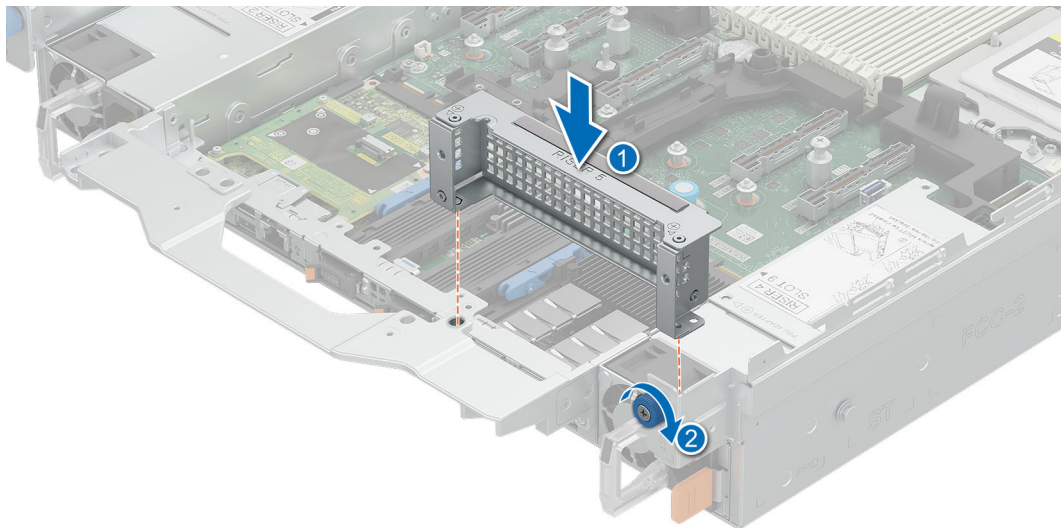

Figure 171. Installing the rear expansion card riser 5 blank

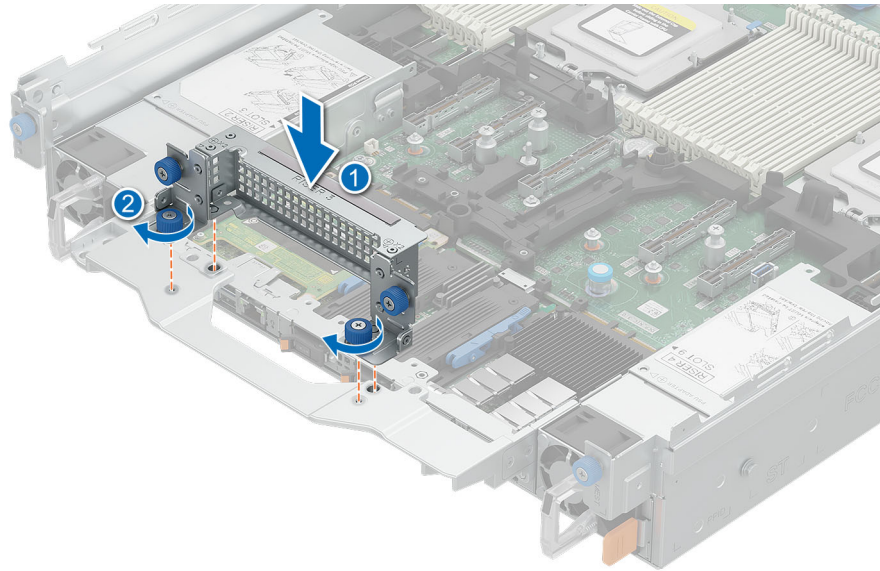

Figure 172. Installing the rear expansion card riser 3 blank

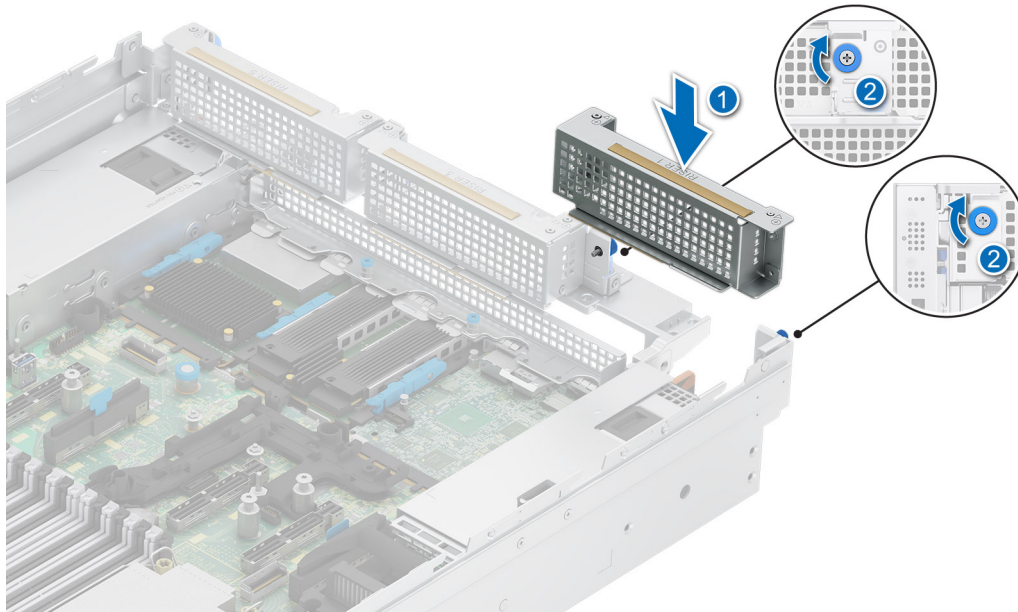

Figure 173. Installing the rear expansion card riser 1 blank

Next steps

1. Follow the procedure listed in [After working inside your system](#).

M.2 SSD module

Removing the M.2 NVMe SSD module

Prerequisites

1. Follow the safety guidelines listed in the [Safety instructions](#).
2. Follow the procedure listed in [Before working inside your system](#).

Steps

1. Pull and lift the BOSS-N1 card carrier retention latch lock to open.
2. Slide the BOSS-N1 card carrier out.

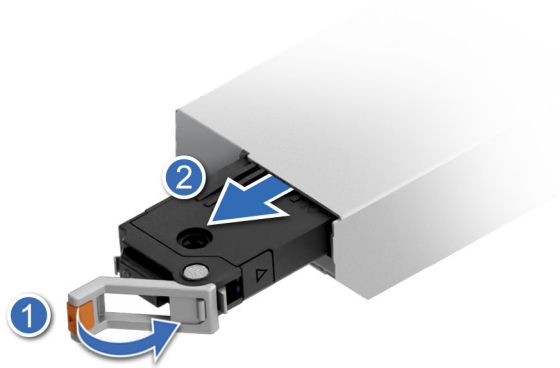

Figure 174. Removing the BOSS-N1 card carrier

3. Using the Phillips 1 screwdriver, loosen the captive screws securing the top cover of the BOSS-N1 card carrier.

NOTE: Follow the sequence to loosen the captive screws. First, loosen the screw at the connector end, and then the screw at the front handle end.



Figure 175. Loosen the top cover captive screws

4. Tilt the top cover from the side and lift the top cover out of the BOSS-N1 card carrier.

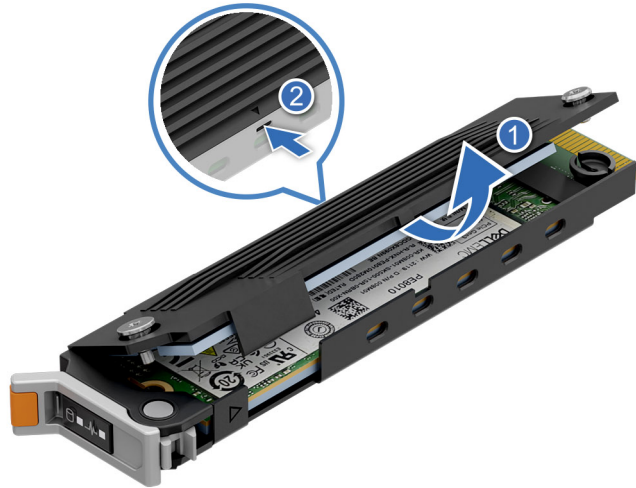

Figure 176. Removing the top cover

5. Lift the M.2 NVMe SSD module to disconnect from the BOSS-N1 card carrier connector.

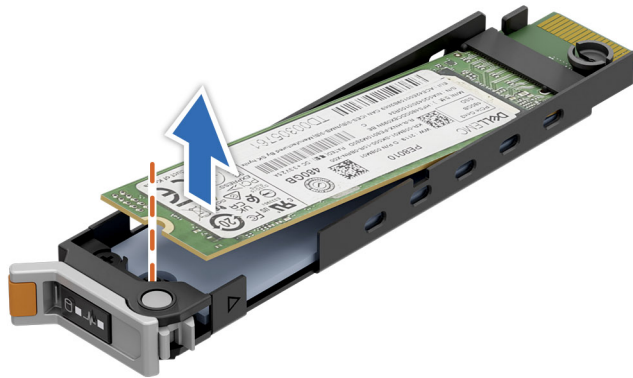

Figure 177. Removing the M.2 NVMe SSD module

NOTE: For information about Thermal pad and BOSS-N1 card carrier replacement, go to [PowerEdge Manuals > Rack Servers > PowerEdge R7725 > Select This Product > Documentation > Manuals and Documents > BOSS-N1 DC-MHS M.2 NVMe SSD Card Installation and Replacement Tech Sheet](#).

Next steps

1. Replace the M.2 NVMe SSD module.

Installing the M.2 NVMe SSD module

Prerequisites

1. Follow the safety guidelines listed in the [Safety instructions](#).
2. Follow the procedure listed in [Before working inside your system](#).
3. Replace the thermal pads on the top and bottom cover of the BOSS-N1 card carrier, when replacing the M.2 NVMe SSD module.

NOTE: For information about Thermal pad and BOSS-N1 card carrier replacement, go to [PowerEdge Manuals > Rack Servers > PowerEdge R7725 > Select This Product > Documentation > Manuals and Documents > BOSS-N1 DC-MHS M.2 NVMe SSD Card Installation and Replacement Tech Sheet](#).

Steps

1. Align the M.2 NVMe SSD module at an angle with the BOSS-N1 card carrier connector.
2. Insert the M.2 NVMe SSD module until it is firmly seated in the BOSS-N1 card carrier connector.

NOTE: Press the M.2 NVMe SSD card until it adheres to the thermal pad.

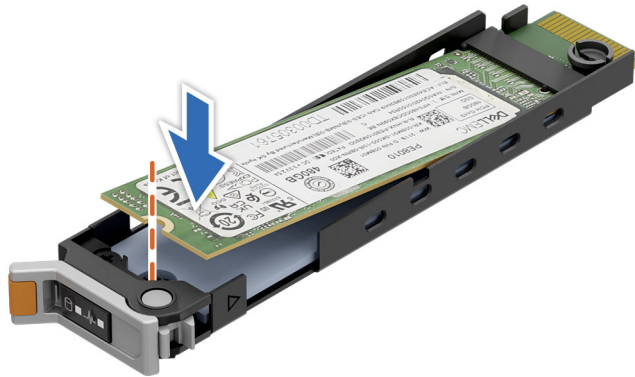

Figure 178. Installing the M.2 NVMe SSD module

3. Align at an angle, place the top cover hook into the slot on the bottom cover of the BOSS-N1 card carrier.
4. Press the opposite side of the top cover until firmly seated.

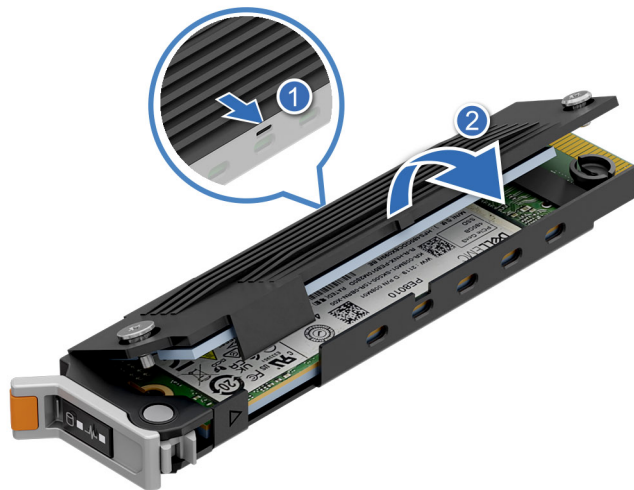

Figure 179. Installing the top cover

5. Using the Phillips 1 screwdriver, tighten the captive screws on the BOSS-N1 card carrier top cover.

NOTE: Follow the sequence to tighten the captive screws. First, tighten the screw available at the front handle end, and then the screw at the connector end.



Figure 180. Tighten the top cover captive screws

6. Slide the BOSS-N1 card carrier into the BOSS-N1 module slot.
7. Close the BOSS-N1 card carrier release latch to lock the carrier in place.



Figure 181. Installing the BOSS-N1 card carrier

Optional BOSS-N1 DC-MHS module

This is a service technician replaceable part only.

Removing the BOSS-N1 DC-MHS controller blank

Prerequisites

1. Follow the safety guidelines listed in the [Safety instructions](#).

Steps

Press and pull the BOSS-N1 card carrier blank out from the BOSS-N1 controller.



Figure 182. Removing the BOSS-N1 card carrier blank

Next steps

1. Replace the BOSS-N1 DC-MHS controller blank or install BOSS-N1 DC-MHS controller.

Installing the BOSS-N1 DC-MHS controller blank

Prerequisites

1. Follow the safety guidelines listed in the [Safety instructions](#).

Steps

Align the blank with the BOSS-N1 controller bay and push it into the bay until it clicks into place.

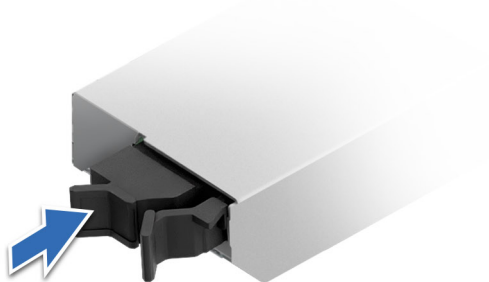

Figure 183. Installing the BOSS-N1 card carrier blank

Removing the rear BOSS-N1 DC-MHS controller

Prerequisites

1. Follow the safety guidelines listed in the [Safety instructions](#).
2. Follow the procedure listed in [Before working inside your system](#).
3. [Remove the expansion card riser](#) or [remove the expansion card riser blanks](#).
4. [Remove the M.2 NVMe SSD module](#).

Steps

1. Open the blue latch to disengage the BOSS-N1 DC-MHS controller.
2. Push the BOSS-N1 DC-MHS controller towards the rear end of the system to disconnect from the connector on the HPM board.
3. Slide the BOSS-N1 DC-MHS controller out of the slot on the system.

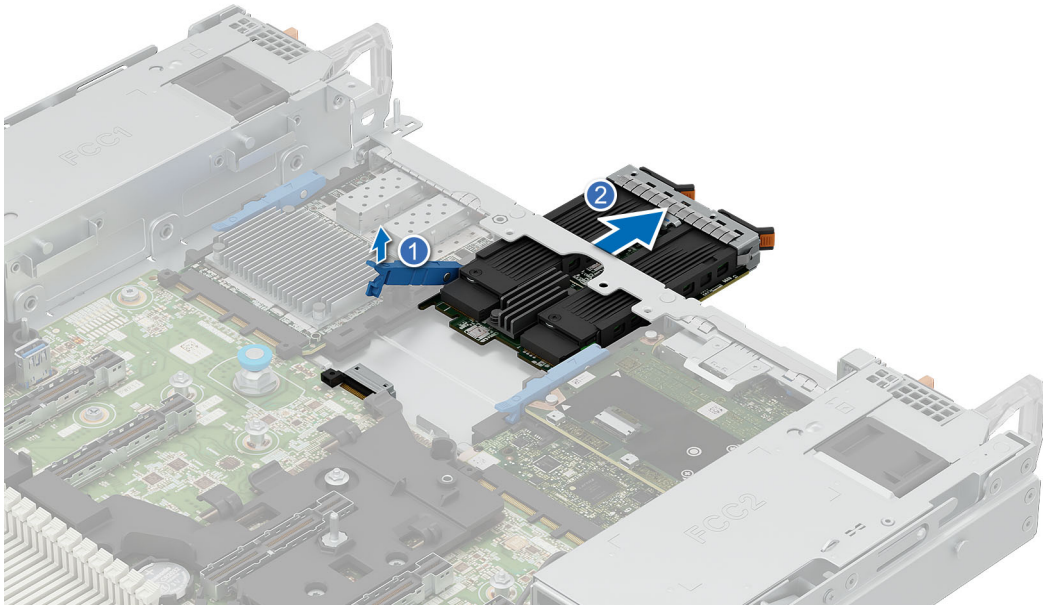

Figure 184. Removing the rear BOSS-N1 DC-MHS controller

4. If you do not plan to replace the BOSS-N1 DC-MHS controller card, install a filler bracket.

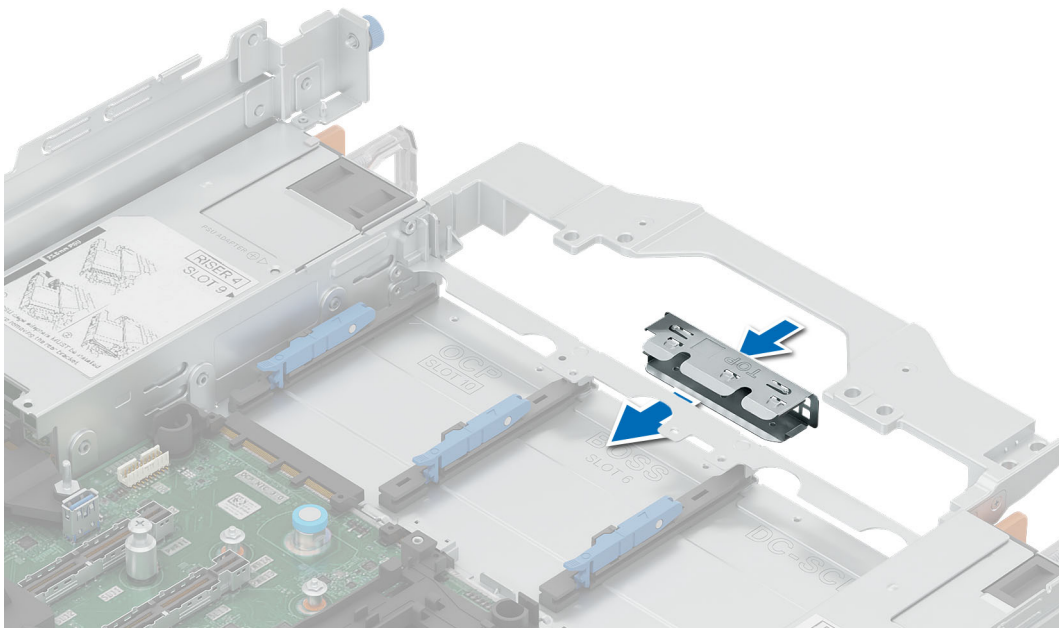

Figure 185. Installation of filler bracket

Next steps

1. Replace the BOSS-N1 DC-MHS controller.

Installing the rear BOSS-N1 DC-MHS controller

Prerequisites

1. Follow the safety guidelines listed in the [Safety instructions](#).
2. Follow the procedure listed in [Before working inside your system](#).
3. [Remove the expansion card riser](#) or [remove the expansion card riser blanks](#).
4. [Remove the M.2 NVMe SSD module](#).

Steps

1. If installed, remove the filler bracket.

i **NOTE:** Store the filler bracket for future use. Filler brackets must be installed in empty expansion card slots to maintain Federal Communications Commission (FCC) certification of the system. The brackets also keep dust and dirt out of the system and aid in proper cooling and airflow inside the system.

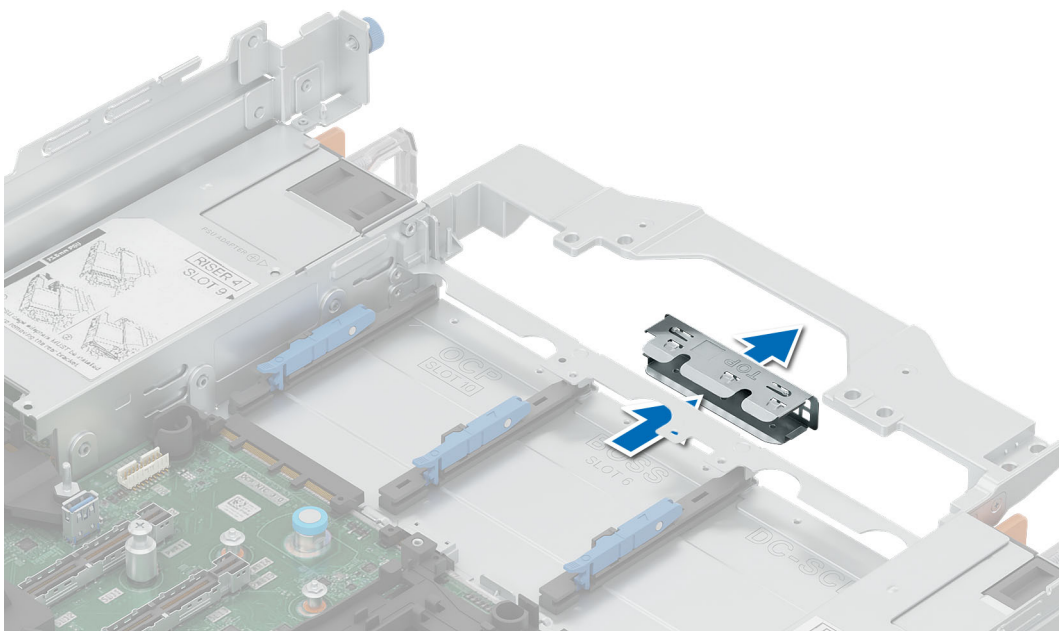

Figure 186. Removal of filler bracket

2. Open the blue latch on the HPM board.
3. Slide the BOSS-N1 DC-MHS controller into the slot in the system.
4. Push until the BOSS-N1 DC-MHS controller is connected to the connector on the HPM board.
5. Close the blue latch to lock the BOSS-N1 DC-MHS controller to the system.

i **NOTE:** The numbers on the image do not depict the exact steps. The numbers are for representation of sequence.

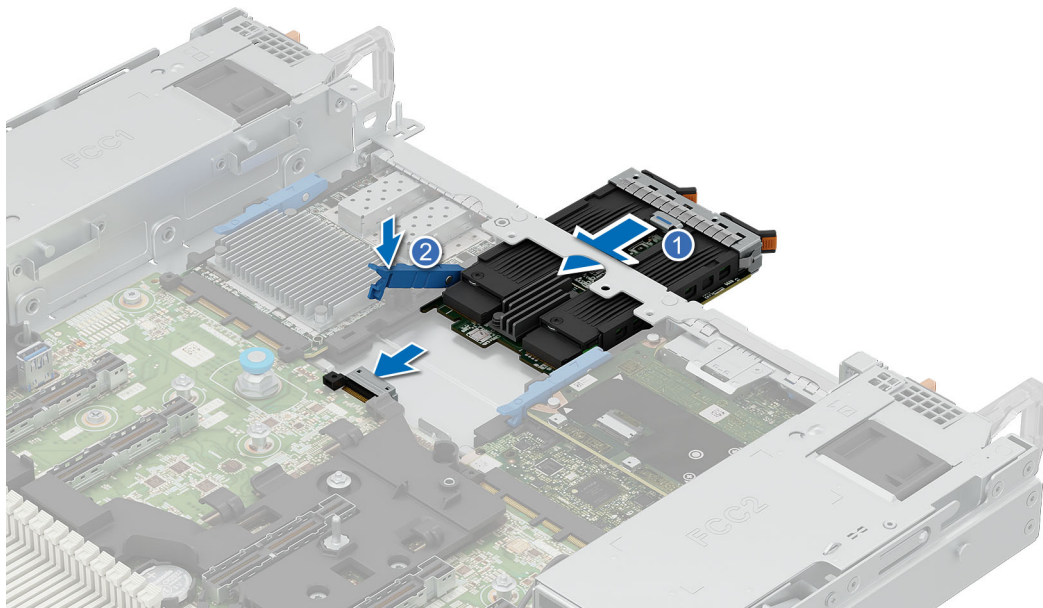

Figure 187. Installing the BOSS-N1 DC-MHS controller

Next steps

1. [Install the M.2 NVMe SSD module.](#)
2. [Install the expansion card riser or install the expansion card riser blanks.](#)
3. Follow the procedure listed in the [After working inside your system.](#)

Optional OCP NIC card

Removing the OCP NIC card

Prerequisites

1. Follow the safety guidelines listed in the [Safety instructions.](#)
2. Follow the procedure listed in the [Before working inside your system.](#)
3. If required, [remove the air shroud.](#)
4. [Remove the expansion card riser or remove the expansion card riser blanks.](#)

Steps

1. Open the blue latch to disengage the OCP NIC card.
2. Push the OCP NIC card towards the rear end of the system to disconnect from the connector on the HPM board.
3. Slide the OCP NIC card out of the slot on the system.

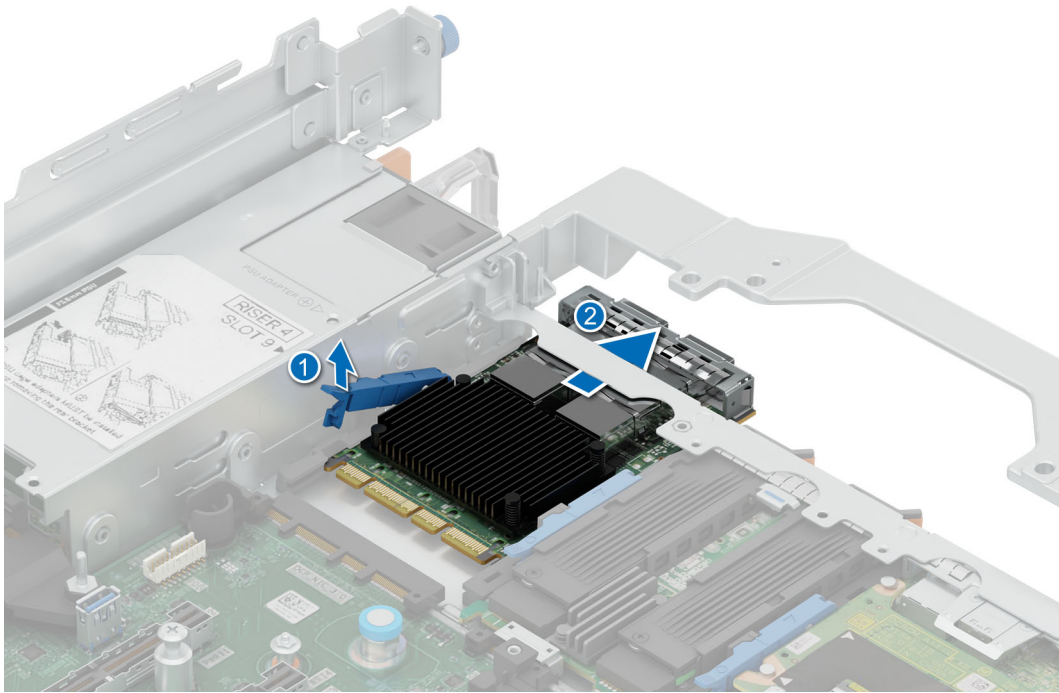

Figure 188. Removing the OCP NIC card

4. If the OCP NIC card is not going to be replaced, install a filler bracket .

i **NOTE:** You must install a filler bracket over an empty expansion card slot to maintain Federal Communications Commission (FCC) certification of the system. The brackets also keep dust and dirt out of the system and aid in proper cooling and airflow inside the system.

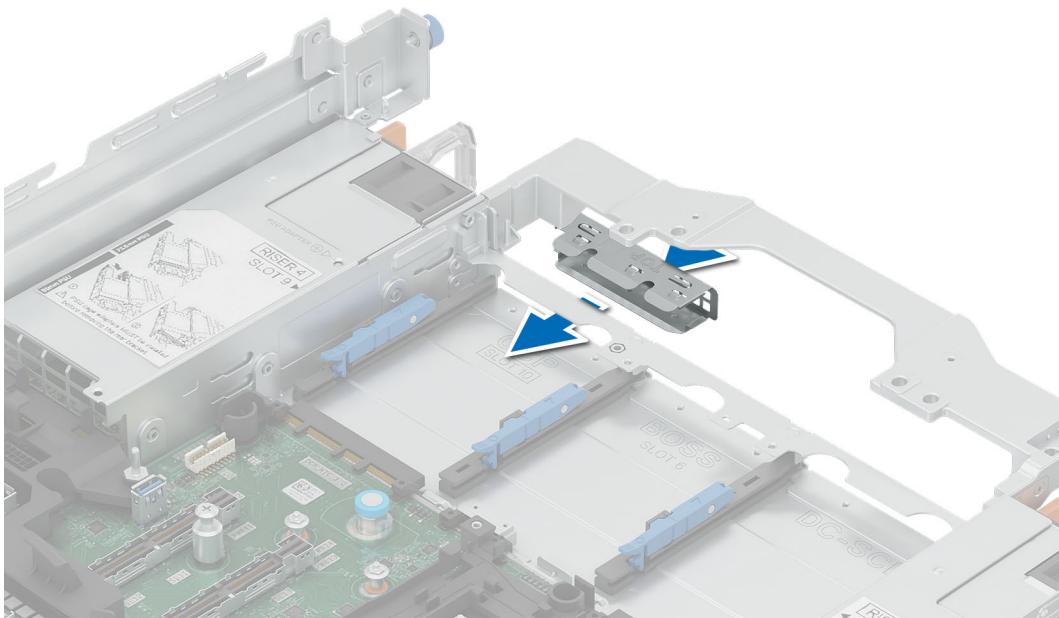

Figure 189. Installation of filler bracket

Next steps

1. Replace the OCP NIC card.

Installing the OCP NIC card

Prerequisites

1. Follow the safety guidelines listed in the [Safety instructions](#).
2. Follow the procedure listed in the [Before working inside your system](#).
3. If required, [remove the air shroud](#).
4. [Remove the expansion card riser](#) or [remove the expansion card riser blanks](#).

CAUTION: Do not install GPUs, network cards, or other PCIe devices on your system that are not validated and tested by Dell. Damage caused by unauthorized and invalidated hardware installation will null and void the system warranty.

Steps

1. If installed, remove the filler bracket.

NOTE: Store the filler bracket for future use. Filler brackets must be installed in empty expansion card slots to maintain Federal Communications Commission (FCC) certification of the system. The brackets also keep dust and dirt out of the system and aid in proper cooling and airflow inside the system.

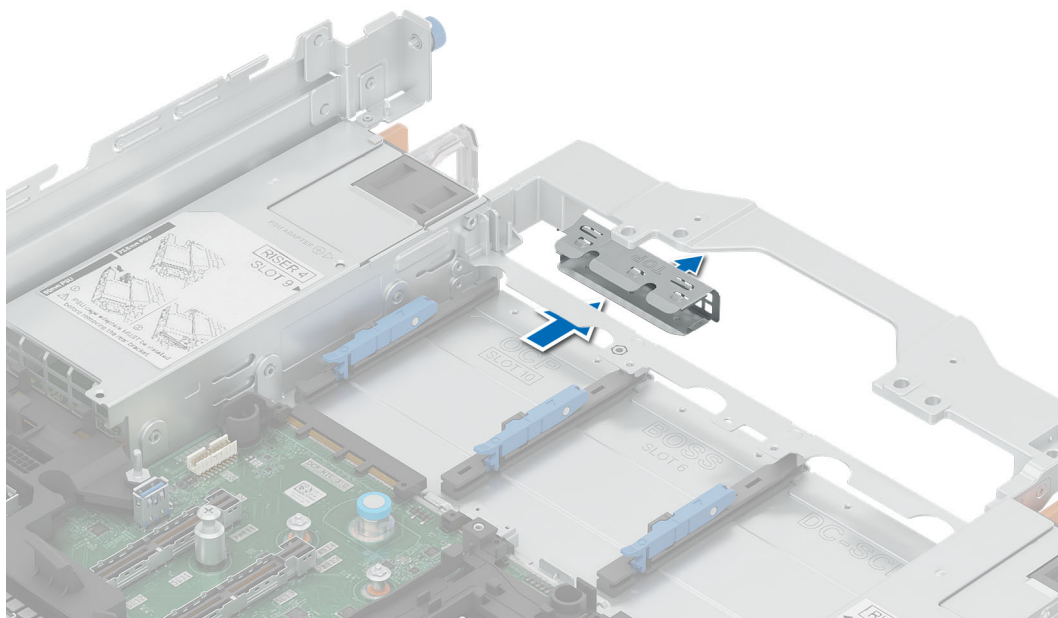

Figure 190. Removal of filler bracket

2. Open the blue latch on the HPM board.
3. Slide the OCP NIC card into the slot in the system.
4. Push until the OCP NIC card is connected to the connector on the HPM board.
5. Close the blue latch to lock the OCP NIC card to the system.

NOTE: The numbers on the image do not depict the exact steps. The numbers are for representation of sequence.

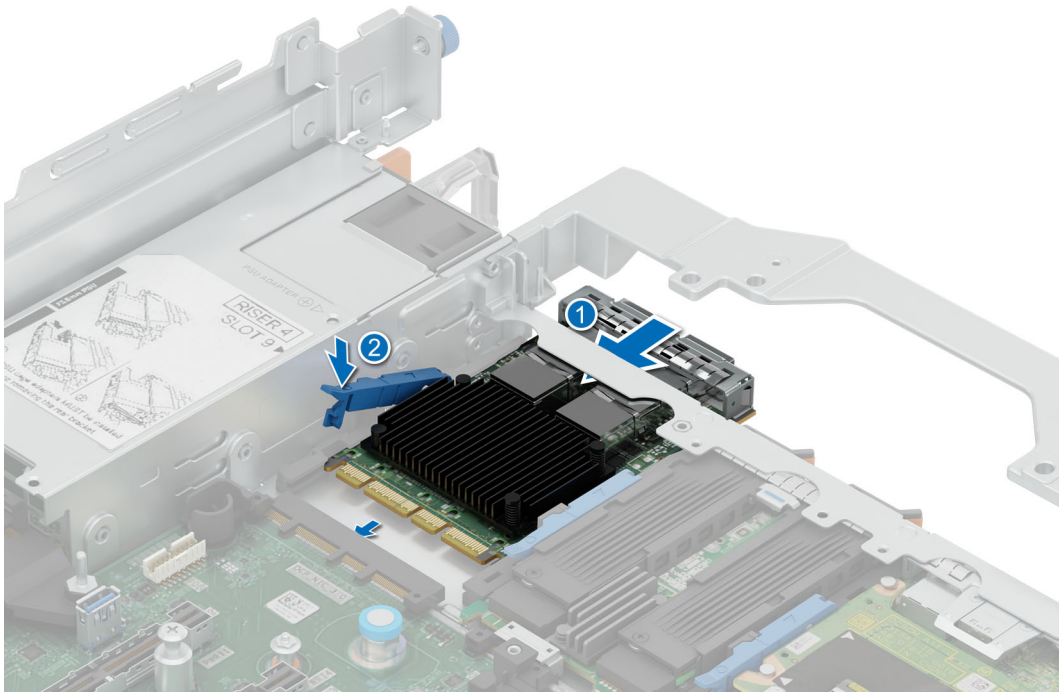

Figure 191. Installing the OCP NIC card

Next steps

1. [Install the expansion card riser](#) or [install the expansion card riser blanks](#)
2. If removed, [install the air shroud](#).
3. Follow the procedure listed in [After working inside your system](#).

Datacenter-Secure Control Module (DC-SCM)

This is a service technician replaceable part only.

Removing the DC-SCM board

Prerequisites

1. Follow the safety guidelines listed in the [Safety instructions](#).
2. Follow the procedure listed in the [Before working inside your system](#).
3. If required, [remove the air shroud](#).
4. [Remove the expansion card riser](#) or [remove the expansion card riser blanks](#).

NOTE: Disconnect the Attic cable, see [cable routing](#) section.

Steps

1. Open the blue latch to disengage the DC-SCM board.
2. Push the DC-SCM board towards the rear end of the system to disconnect from the connector on the HPM board.
3. Slide the DC-SCM board out of the slot on the system.

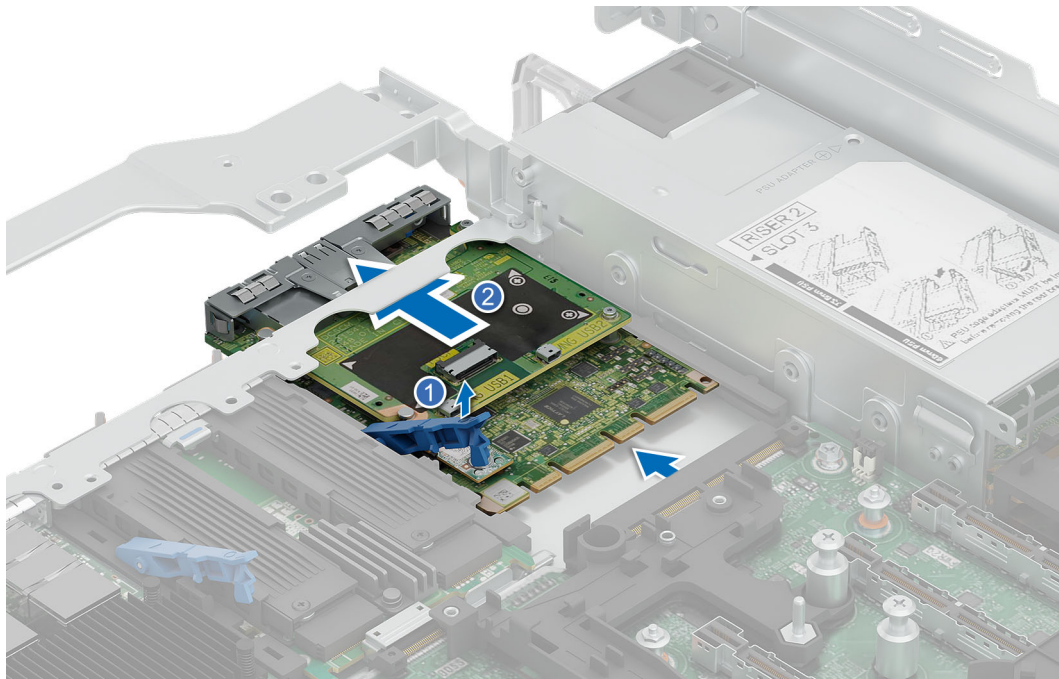

Figure 192. Removing the DC-SCM board

Next steps

NOTE: If a new DC-SCM board is being installed, the Attic board must be removed from the existing DC-SCM board and installed on the new board.

1. Remove the Attic card.
2. Replace the DC-SCM board.

Installing the DC-SCM board

Prerequisites

1. Follow the safety guidelines listed in the [Safety instructions](#).
2. Follow the procedure listed in the [Before working inside your system](#).
3. If required, [remove the air shroud](#).
4. [Remove the expansion card riser](#) or [remove the expansion card riser blanks](#).
5. [Remove the Attic board](#).

NOTE: Disconnect the Attic cable, see [cable routing](#) section.

CAUTION: Do not install GPUs, network cards, or other PCIe devices on your system that are not validated and tested by Dell. Damage caused by unauthorized and invalidated hardware installation will null and void the system warranty.

Steps

1. Open the blue latch on the HPM board.
2. Slide the DC-SCM board into the slot in the system.
3. Push until the DC-SCM board is connected to the connector on the HPM board.
4. Close the blue latch to lock the DC-SCM board to the system.

NOTE: The numbers on the image do not depict the exact steps. The numbers are for representation of sequence.

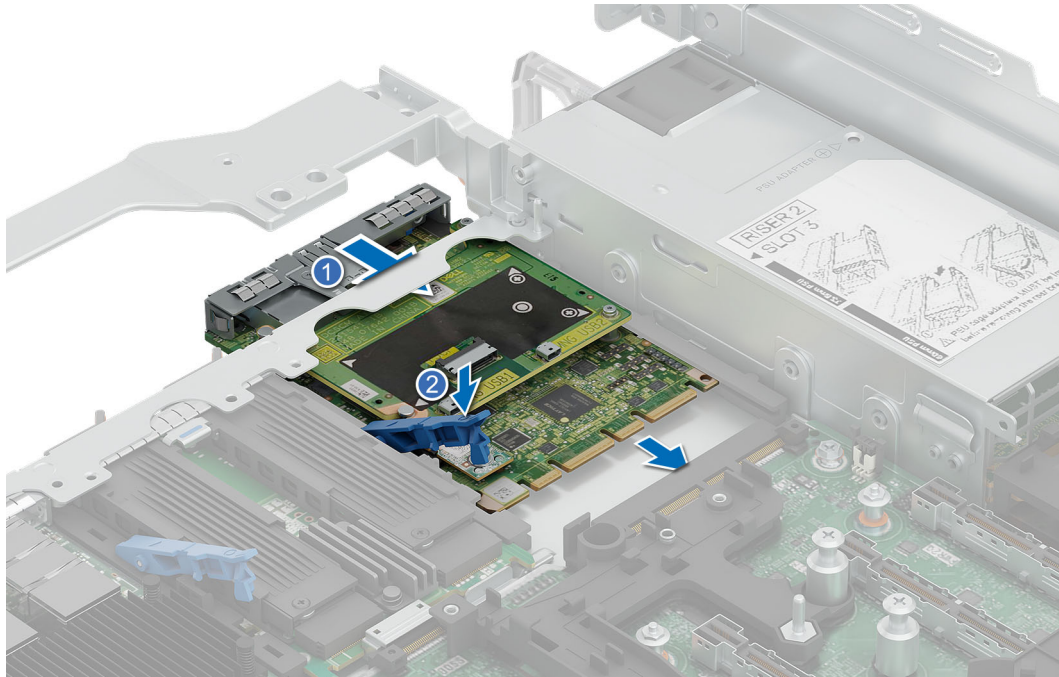

Figure 193. Installing the DC-SCM board

Next steps

1. [Install the Attic board.](#)

NOTE: Connect the Attic cable, see [cable routing](#) section.

2. [Install the expansion card riser](#) or [install the expansion card riser blanks.](#)
3. If removed, [install the air shroud.](#)
4. Power on the system.
5. Ensure that you perform the following steps:
 - a. Use the Easy Restore feature to restore the BIOS and Service Tag. See the [Restoring the system using the Easy Restore feature](#) section.
 - b. If the service tag is not backed up in the backup flash device, enter the system service tag manually. See the [Manually update the Service Tag](#) by using System Setup section.
 - c. Update the BIOS and iDRAC versions, Diagnostics, and OS Driver Pack and OS Collector.
 - d. Re-enable the Trusted Platform Module (TPM). See the [Initializing the Trusted Platform Module](#) section.
6. Follow the procedure listed in [After working inside your system.](#)

Attic board

This is a service technician replaceable part only.

Removing the Attic board

Prerequisites

1. Follow the safety guidelines listed in the [Safety instructions.](#)
2. Follow the procedure listed in the [Before working inside your system.](#)
3. If required, [remove the air shroud.](#)
4. [Remove the expansion card riser](#) or [remove the expansion card riser blanks.](#)
5. [Remove the DC-SCM board.](#)

NOTE: Disconnect the Attic cable, see [cable routing](#) section.

Steps

1. Using the Phillips 1 screwdriver, loosen the captive screws securing the attic board to the DC-SCM board.
2. Tilt and lift the Attic board from the DC-SCM guides.

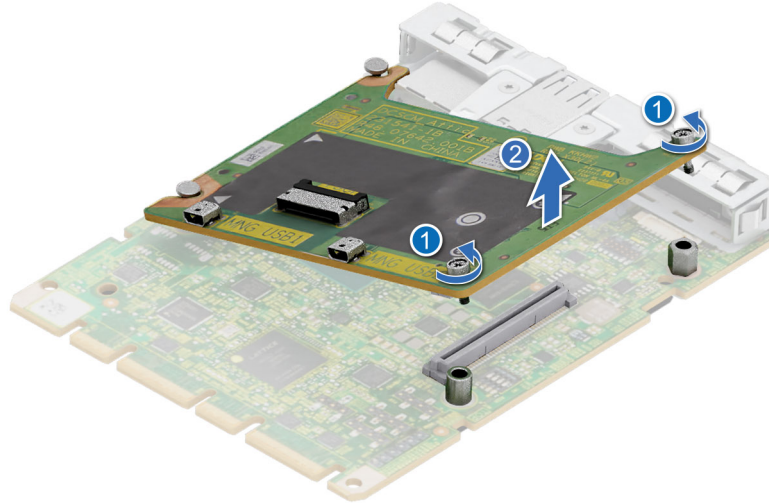

Figure 194. Removing the Attic board

Next steps

1. [Replace the Attic board.](#)

Installing the Attic board

Prerequisites

1. Follow the safety guidelines listed in the [Safety instructions](#).
2. Follow the procedure listed in the [Before working inside your system](#).
3. If required, [remove the air shroud](#).
4. [Remove the expansion card riser](#) or [remove the expansion card riser blanks](#).
5. [Remove the DC-SCM board](#).

NOTE: Disconnect the Attic cable, see [cable routing](#) section.

CAUTION: Do not install GPUs, network cards, or other PCIe devices on your system that are not validated and tested by Dell. Damage caused by unauthorized and invalidated hardware installation will null and void the system warranty.

Steps

1. Align the Attic board at an angle with the guides on the DC-SCM board.
2. Press until the Attic board is connected to the connector on the DC-SCM board.
3. Using a Phillips 1 screwdriver, tighten the captive screws.

NOTE: The numbers on the image do not depict the exact steps. The numbers are for representation of sequence.

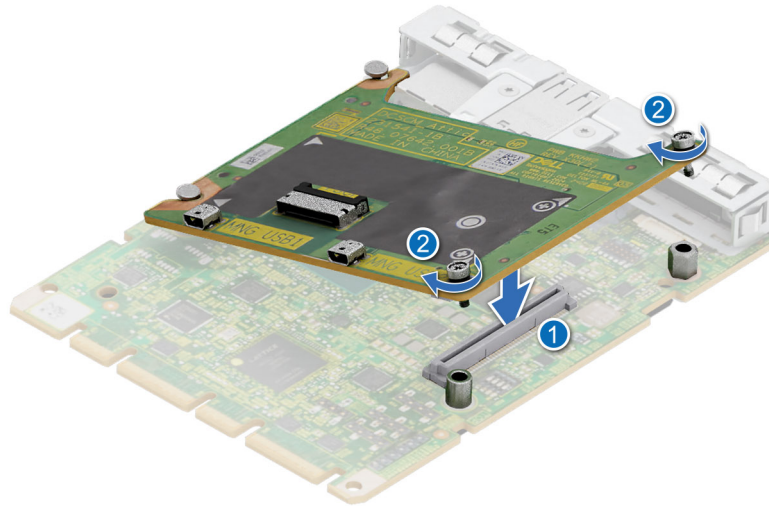

Figure 195. Installing the Attic board

Next steps

1. Install the DC-SCM board.

NOTE: Connect the Attic cable, see [cable routing](#) section.

2. Install the expansion card riser or install the expansion card riser blanks.
3. If removed, install the air shroud.
4. Follow the procedure listed in [After working inside your system](#).

Restoring the system using Easy Restore

The Easy Restore feature restores the server service tag and BIOS configuration data after replacing the Datacenter-Secure Control Module (DC-SCM). System configuration data is automatically maintained in a backup flash device within the system. If the BIOS detects a new DC-SCM during server boot, the system prompts the user to restore the backup system configuration data.

About this task

When the DC-SCM is booted for the first time, it presents a screen with settings it can restore, below is a list of options/steps available:

Steps

1. To restore the system configuration data, press **Y**
2. To skip restore for this boot, press **N**
3. Enter BIOS setup to manually restore Service Tag, press **F2**

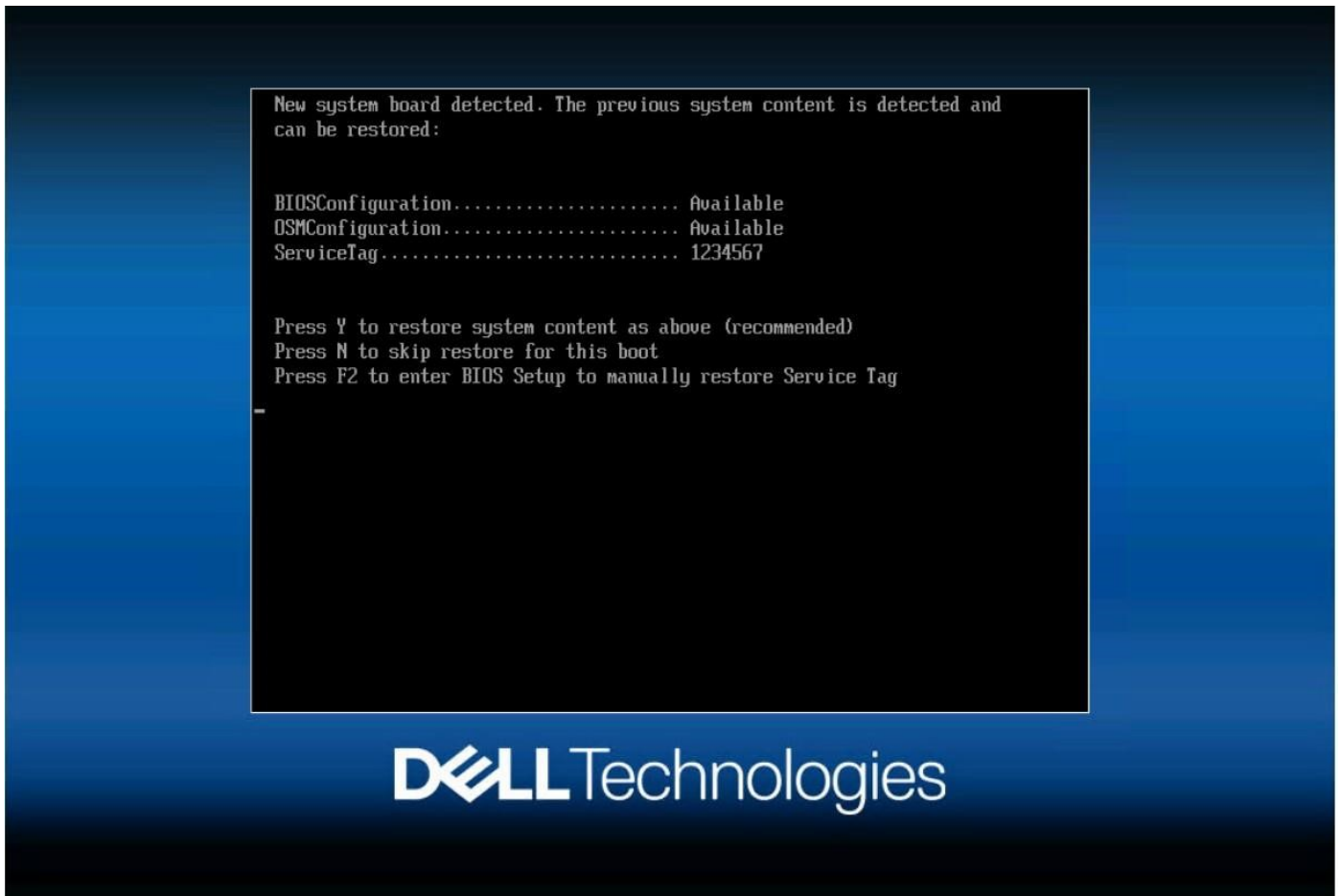

Figure 196. Easy Restore

Manually update the Service Tag

After replacing a HPM board, if Easy Restore fails, follow this process to manually enter the Service Tag, using **System Setup**.

About this task

If you know the system service tag, use the **System Setup** menu to enter the service tag.

Steps

1. Power on the system.
2. To enter the **System Setup**, press **F2**.
3. Click **Service Tag Settings**.
4. Enter the service tag.

NOTE: You can enter the service tag only when the **Service Tag** field is empty. Ensure that you enter the correct service tag. Once the service tag is entered, it cannot be updated or changed. Incorrectly entered service tag will lead to HPM board replacement.

5. Click **OK**.

Optional internal USB port

This is a service technician replaceable part only.

Replacing the optional internal USB card

Prerequisites

CAUTION: To avoid interference with other components in the server, the maximum permissible length of the USB card is 31.32 mm.

1. Follow the safety guidelines listed in the [Safety instructions](#).
2. Follow the procedure listed in the [Before working inside your system](#).
3. If required, [remove the air shroud](#).
4. [Remove the expansion card riser](#) or [remove the expansion card riser blanks](#).

Steps

1. Locate the USB card on the HPM board.
To locate the USB port, see the [HPM board connectors](#).
2. Lift the internal USB card to disconnect from the connector on the HPM board.

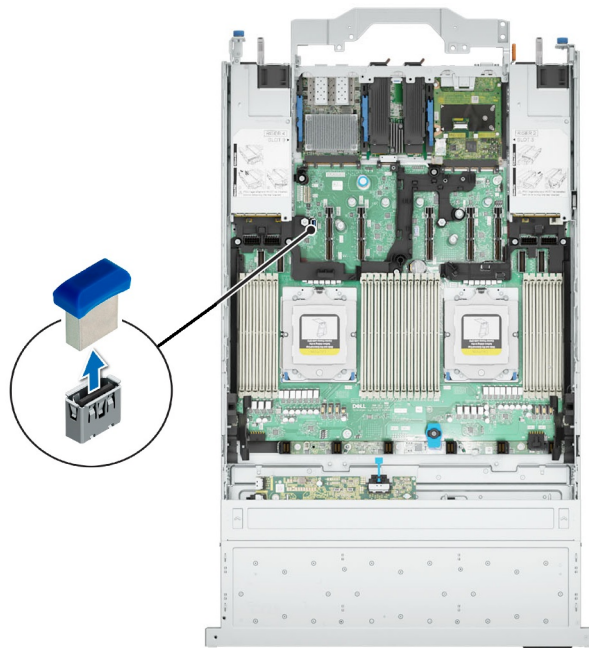

Figure 197. Removing the internal USB

3. Insert the replacement USB card into the connector on the HPM board.

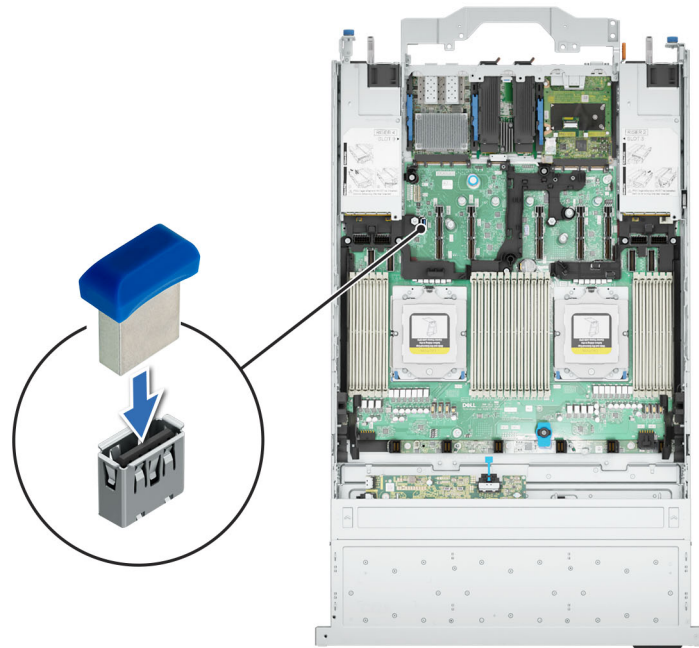

Figure 198. Installing the internal USB

Next steps

1. If removed, [install the expansion card risers](#).
2. If removed, [install the air shroud](#).
3. Follow the procedure listed in [After working inside your system](#).
4. While booting, press F2 to enter **System Setup** and verify that the system detects the USB memory key.

System battery

This is a service technician replaceable part only.

Replacing the system battery

Prerequisites

⚠ WARNING: There is a danger of a new battery exploding if it is incorrectly installed. Replace the battery only with the same or equivalent type that is recommended by the manufacturer. Discard used batteries according to the manufacturer's instructions. See the Safety instructions that came with your system for more information.

1. Follow the safety guidelines listed in the [Safety instructions](#).
2. Follow the procedure listed in the [Before working inside your system](#).
3. If required, [remove the air shroud](#).
4. [Remove the expansion card riser](#).

Steps

1. Press and hold the battery socket retention latch, for the battery to pop out.

i NOTE: If the battery does not pop out, then lift it out of the socket.

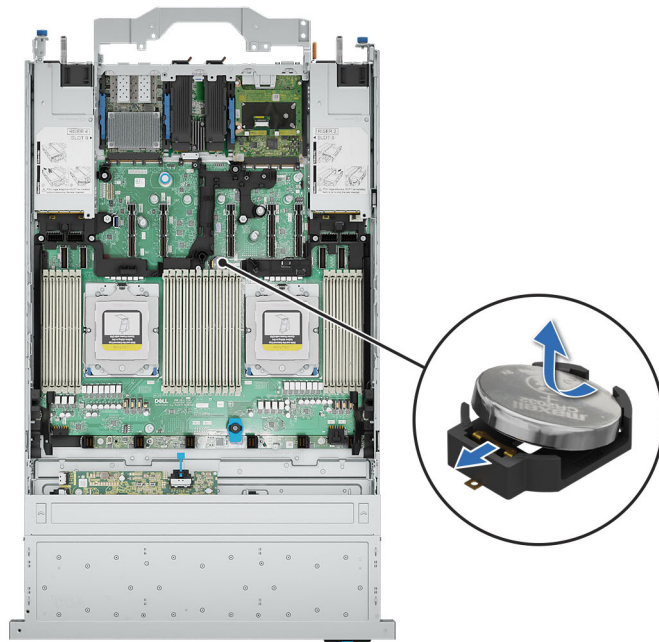

Figure 199. Removing the system battery

2. To install a new system battery, hold the battery with the positive side facing up at an angle and slide it under the battery holder socket latch.
3. Press the battery into the connector until it snaps into place.

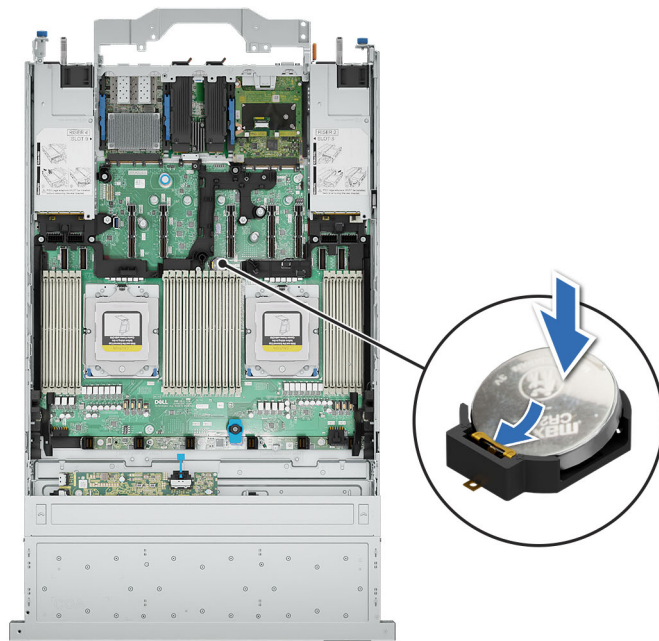

Figure 200. Installing the system battery

Next steps

1. [Install the expansion card risers.](#)
2. If applicable, connect the cables to one or more expansion cards.
3. Follow the procedure listed in [After working inside your system.](#)
4. Confirm that the battery is operating properly, by performing the following steps:
 - a. Enter the System Setup, while booting, by pressing F2.

- b. Enter the correct time and date in the System Setup **Time** and **Date** fields.
- c. **Exit** the System Setup.
- d. To test the newly installed battery, check the time and date at least an hour after installing the battery.
- e. Enter the System Setup and if the time and date are still incorrect, see [Getting help](#) section.

Intrusion switch

This is a service technician replaceable part only.

Removing the intrusion switch module

Prerequisites

1. Follow the safety guidelines listed in the [Safety instructions](#).
2. Follow the procedure listed in the [Before working inside your system](#).
3. [Remove the expansion card riser](#).

i **NOTE:** Ensure that you note the routing of the cable as you remove it from the HPM board. Route the cable properly when you replace it to prevent the cable from being pinched or crimped.

Steps

1. Using a Phillips 1 screwdriver, loosen the screws on the intrusion switch module.
2. Disconnect the intrusion switch cable and the dongle cable.

i **NOTE:** The intrusion switch cable is connected to the dongle cable, which in turn is connected to the HPM board. See the [cable routing](#) section.

3. Disconnect the dongle cable from the connector on the HPM board.

i **NOTE:** Detach the cable from the intrusion switch and keep it safe to be used when replacing with the new intrusion switch.

4. Lift the intrusion switch module along with dongle cable out of the system.

i **NOTE:** The numbers on the image do not depict the exact steps. The numbers are for representation of sequence.

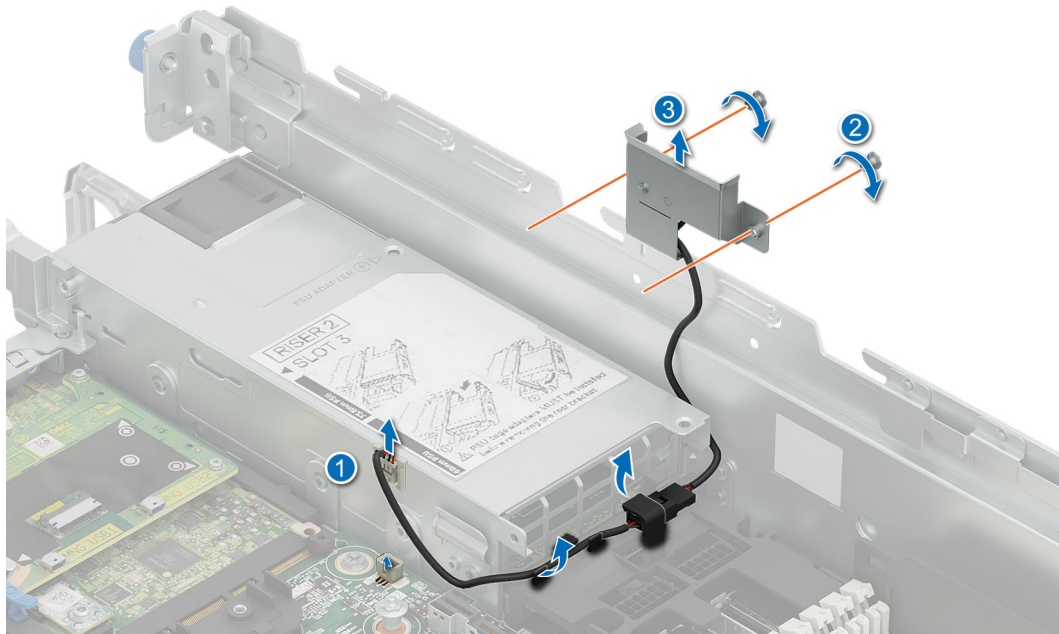

Figure 201. Removing the intrusion switch module

Next steps

1. [Replace the intrusion switch module.](#)

Installing the intrusion switch module

Prerequisites

1. Follow the safety guidelines listed in the [Safety instructions](#).
2. Follow the procedure listed in the [Before working inside your system](#).
3. [Remove the expansion card riser.](#)

Steps

1. Align and place the intrusion switch module into the system.
2. Using a Phillips 1 screwdriver, tighten the screws to secure the intrusion switch module to the system chassis.
3. Connect the dongle cable to the connector on the HPM board.
4. Reconnect the dongle cable in the connector on the HPM board.

NOTE: The intrusion switch cable is connected to the dongle cable, which in turn is connected to the HPM board. See the [cable routing](#) section.

NOTE: When routing the cable, ensure you route it properly to avoid pinching or crimping.

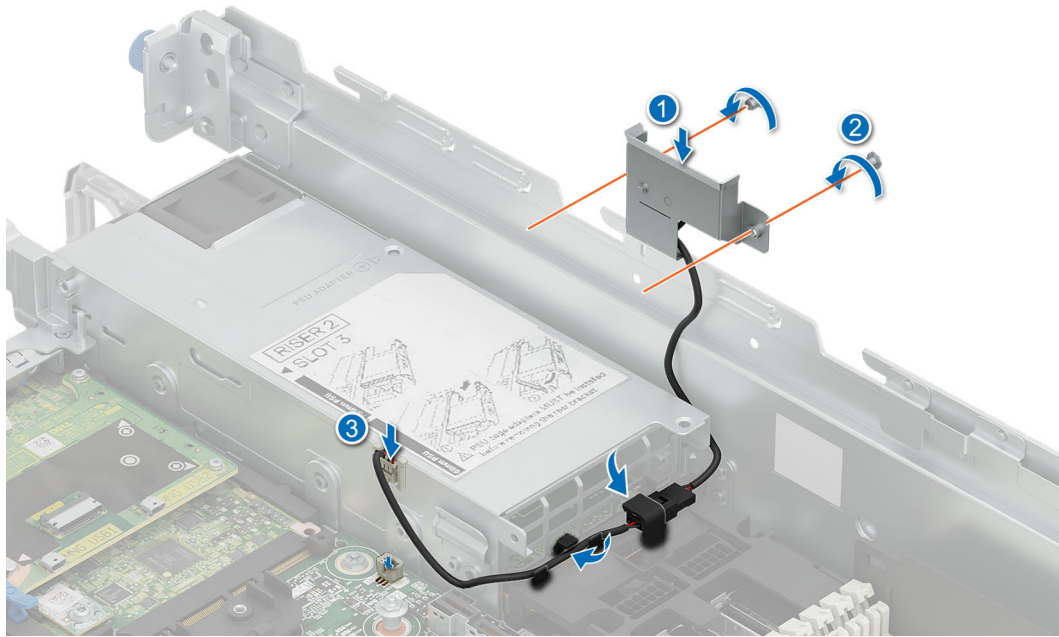

Figure 202. Installing the intrusion switch module

Next steps

1. [Install the rear expansion card riser.](#)
2. Follow the procedure listed in [After working inside your system.](#)

Power supply unit

Hot spare feature

Your system supports the hot spare feature that significantly reduces the power overhead associated with power supply unit (PSU) redundancy.

When the hot spare feature is enabled, one of the redundant PSUs is switched to the sleep state. The active PSU supports 100 percent of the system load, thus operating at higher efficiency. The PSU in the sleep state monitors output voltage of the active PSU. If the output voltage of the active PSU drops, the PSU in the sleep state returns to an active output state.

If having both PSUs active is more efficient than having one PSU in the sleep state, the active PSU can also activate the sleeping PSU.

The default PSU settings are as follows:

- If the load on the active PSU is more than 50 percent of PSU rated power wattage, then the redundant PSU is switched to the active state.
- If the load on the active PSU falls below 20 percent of PSU rated power wattage, then the redundant PSU is switched to the sleep state.

You can configure the hot spare feature by using the iDRAC settings. For more information, see the *iDRAC User's Guide* available at [PowerEdge manuals](#).

Removing a power supply unit blank

Prerequisites

Follow the safety guidelines listed in the [Safety instructions](#).

Steps

Pull the PSU blank out of the system.

CAUTION: For proper system cooling, the PSU blank must be installed in the second PSU bay in a non-redundant configuration. Remove the PSU blank only if you are installing a second PSU.

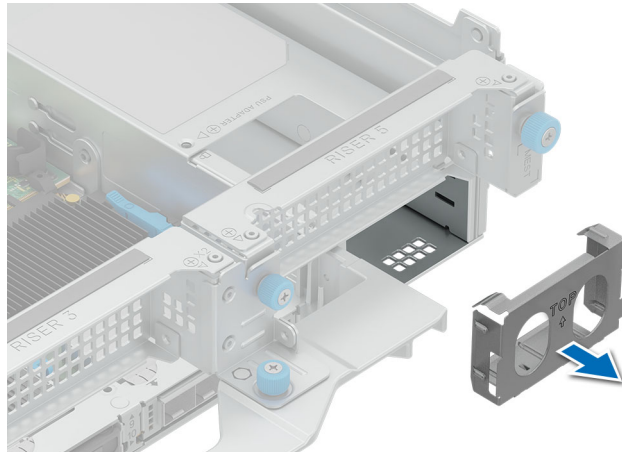

Figure 203. Removing a 60 mm power supply unit blank

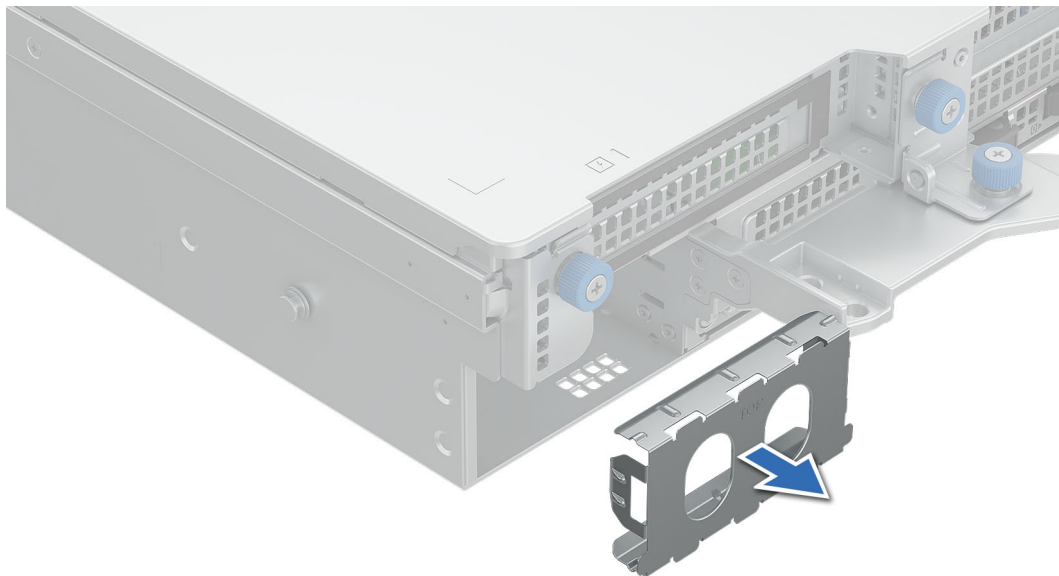

Figure 204. Removing a 73.5 mm power supply unit blank

Next steps

1. [Replace the PSU blank](#) or [install the PSU](#).

Installing a power supply unit blank

Prerequisites

1. Follow the safety guidelines listed in the [Safety instructions](#).

NOTE: Install the power supply unit (PSU) blank only in the second PSU bay.

2. If required, [remove the PSU](#).

Steps

Align the PSU blank with the PSU bay and push it into the PSU bay until it clicks into place.

NOTE: Ensure that the "Top" mark on the PSU blank is on the upper side.

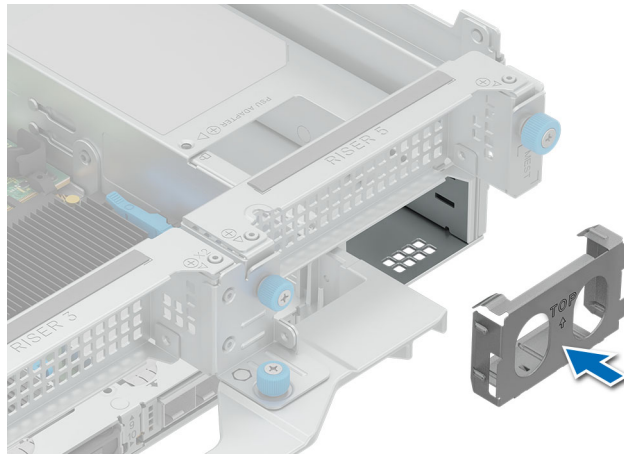

Figure 205. Installing a 60 mm power supply unit blank

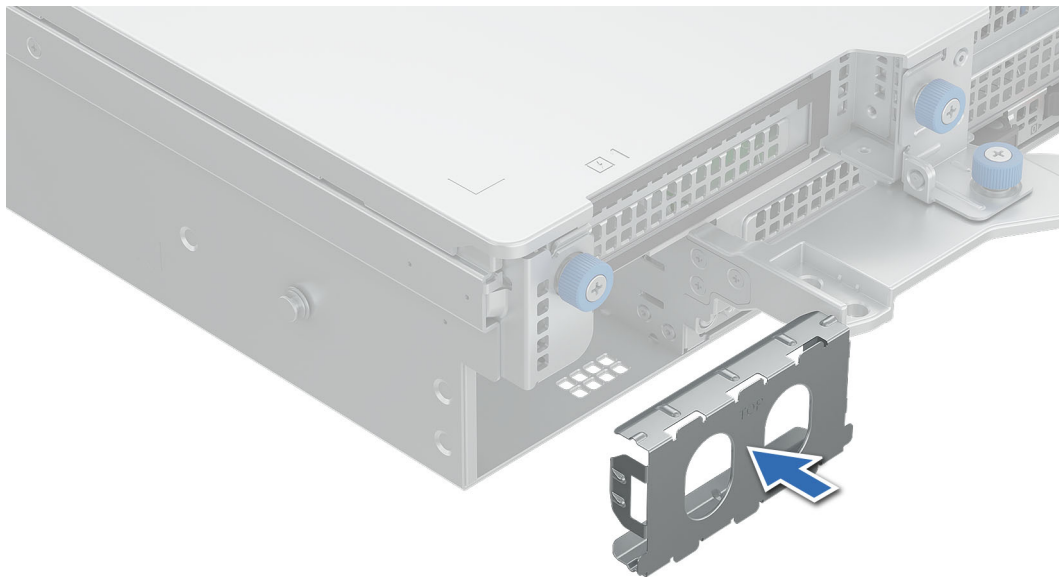

Figure 206. Installing the 73.5 mm power supply unit blank

Removing a power supply unit

Prerequisites

CAUTION: The system requires one power supply unit (PSU) for normal operation.

1. Follow the safety guidelines listed in the [Safety instructions](#).
2. Disconnect the power cable from the power outlet and from the PSU that you intend to remove.
3. Remove the cable from the strap on the PSU handle.
4. Unlatch and lift or remove the optional cable management accessory if it interferes with the PSU removal.

NOTE: For information about the cable management when the PSU is removed or installed while the system is in a rack, see the system's cable management arm documentation at [PowerEdge Manuals](#).

Steps

Press the release latch and holding the PSU handle, slide the PSU out of the bay.

NOTE: Steps to remove the 60 mm and 73.5 mm power supply units are the same.



Figure 207. Removing a power supply unit

Next steps

1. [Replace the PSU](#) or [install the PSU blank](#).

Installing a power supply unit

Prerequisites

1. Follow the safety guidelines listed in the [Safety instructions](#).
2. For systems that support redundant PSU, ensure that both the PSUs are of the same type and have the same maximum output power.

NOTE: The maximum output power (shown in watts) is listed on the PSU label.

3. If required, [Remove the PSU blank](#).

Steps

1. When installing the 73.5 mm power supply unit, [remove the 60 mm power supply filler](#) and [install the PSU bracket](#) first.
2. Slide the 73.5 mm power supply unit until the release latch snaps into place.



Figure 208. Installing the 73.5 mm power supply unit

3. When installing the 60 mm power supply unit, [remove the PSU bracket](#) and [install the 60 mm power supply filler](#) first.
4. Slide the 60 mm power supply unit into the PSU bay until the release latch snaps into place.



Figure 209. Installing a 60 mm power supply unit

Next steps

1. If you have unlatched or removed the cable management accessory, reinstall or relatch it. For information about the cable management when the PSU is removed or installed while the system is in the rack, see the system's cable management accessory documentation at [PowerEdge Manuals](#).
2. Connect the power cable to the PSU, and plug the cable into a power outlet.

CAUTION: When connecting the power cable to the PSU, secure the cable to the PSU with the strap.

NOTE: When installing hot swapping, or hot adding a new PSU, wait for 15 seconds for the system to recognize the PSU and determine its status. The PSU status indicator turns green to indicate that the PSU is functioning properly.

Removing a power supply unit filler

Prerequisites

1. Follow the safety guidelines listed in the [Safety instructions](#).
2. Follow the procedure listed in [Before working inside your system](#).
3. [Remove the PSU](#) or [remove the PSU blank](#).

Steps

1. Using a Phillips 1 screwdriver, loosen the screws on the PSU cage.
2. Disengage the guides and slide out the right PSU filler from the PSU cage.

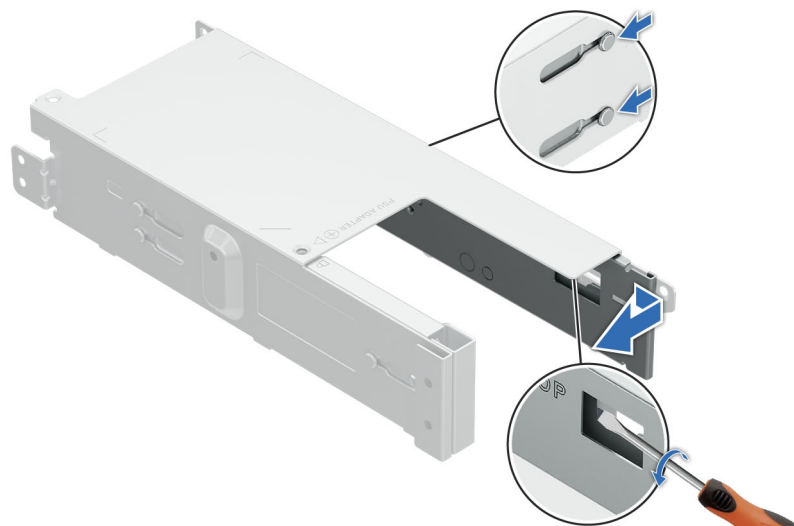

Figure 210. Removing the right PSU filler

3. Using a Phillips 1 screwdriver, loosen the screws on the PSU cage.
4. Disengage the guides and slide out the left PSU filler from the PSU cage.

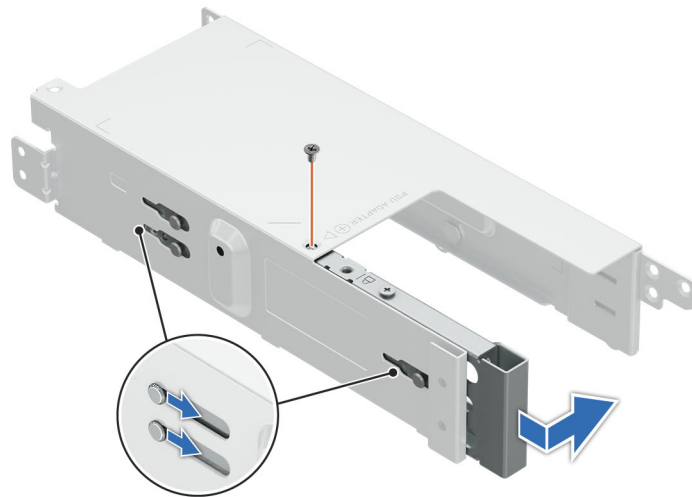

Figure 211. Removing the left PSU filler

Next steps

1. [Replace the PSU filler.](#)

Installing a power supply unit filler

Prerequisites

1. Follow the safety guidelines listed in the [Safety instructions](#).
2. Follow the procedure listed in [Before working inside your system](#).
3. [Remove the PSU](#) or [remove the PSU blank](#).

Steps

1. Align the guides on the filler with the slots on the PSU cage and slide until the filler secured in the PSU cage.
2. Using a phillips 1 screwdriver, tighten the screws.

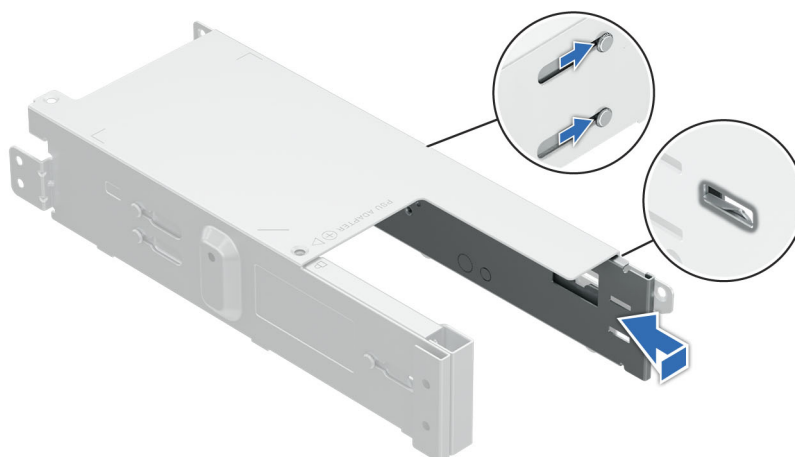

Figure 212. Installing the right PSU filler

3. Align the guides on the filler with the slots on the PSU cage and slide the filler, until the latch is locked with the PSU cage.

4. Using a phillips 1 screwdriver, tighten the screws.

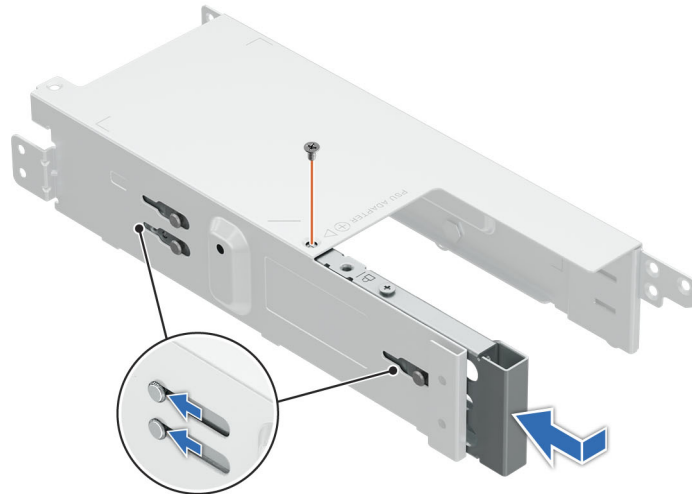

Figure 213. Installing the left PSU filler

Next steps

1. [Install the PSU](#) or [install the PSU blank](#).
2. Follow the procedure listed in [After working inside your system](#).

Removing the PSU bracket

Prerequisites

1. Follow the safety guidelines listed in the [Safety instructions](#).
2. Follow the procedure listed in the [Before working inside your system](#).
3. If required, [remove the air shroud](#).
4. [Remove the expansion card riser](#) or [remove the expansion card riser blanks](#).

Steps

1. Using the Phillips 1 screwdriver, remove the screws that are securing the PSU bracket.
2. Slide the PSU bracket out from the power supply unit cage.

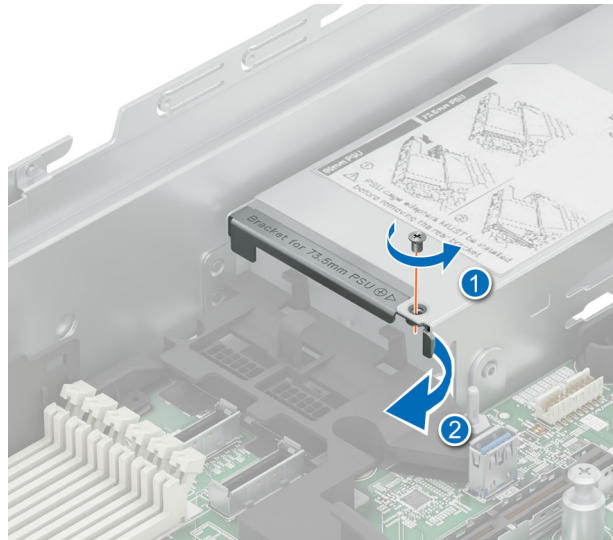

Figure 214. Removing the PSU bracket

Next steps

1. [Replace the PSU bracket.](#)

Installing the PSU bracket

Prerequisites

1. Follow the safety guidelines listed in the [Safety instructions](#).
2. Follow the procedure listed in the [Before working inside your system](#).
3. If required, [remove the air shroud](#).
4. [Remove the expansion card riser](#) or [remove the expansion card riser blanks](#).

Steps

1. Align the PSU bracket with the pin hole on the PSU cage and slide the bracket into place.
2. Using a Phillips 1 screwdriver, secure the PSU bracket in place.

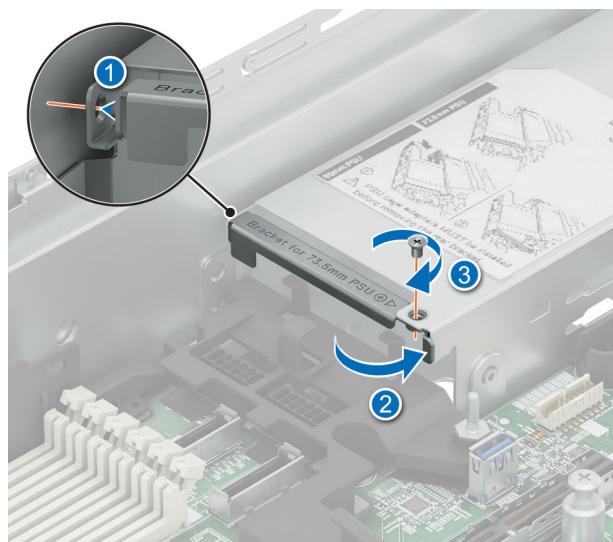

Figure 215. Installing the PSU bracket

Next steps

1. [Install the expansion card riser](#) or [install the expansion card riser blanks](#)
2. If removed, [install the air shroud](#).
3. Follow the procedure listed in [After working inside your system](#).

Trusted Platform Module

TPM is soldered down to the DC-SCM.

If the Trusted Platform Module (TPM) is identified as the root cause of the problem, a full DC-SCM replacement is necessary.

For more information on TPM see [Trusted Platform Module \(TPM\) Summary](#).

Initializing TPM 2.0 for users

Steps

1. Initialize the TPM.
 - a. While booting your system, press F2 to enter System Setup.
 - b. On the **System Setup Main Menu** screen, click **System BIOS > System Security Settings**.
 - c. From the **TPM Security** option, select **On**.
 - d. Save the settings.
 - e. Restart your system.
2. The **TPM Status** changes to **Enabled, Activated**.

TPM Support

Table 83. TPM Support

OS	Resource Link
Microsoft Windows Server 2022	Dell KB article for Windows server 2022
Red Hat Enterprise Linux 7.3	RHE Linux

BitLocker Key: It is important to backup the BitLocker key incase of possible replacement of HPM board and/or TPM card.

Refer [backup BitLocker recovery key](#) for steps.

HPM board

This is a service technician replaceable part only.

 **NOTE:** System board is know as Host Processor Module (HPM) board.

Removing the HPM board

Prerequisites

 **CAUTION:** If you are using the Trusted Platform Module (TPM) with an encryption key, you may be prompted to create a recovery key during program or System Setup. Be sure to create and safely store this recovery key. If you replace this HPM board, you must supply the recovery key when you restart your system or program before you can access the encrypted data on your drives.

1. Follow the safety guidelines listed in the [Safety instructions](#).
2. Follow the procedure listed in the [Before working inside your system](#).
3. Remove the following components:

- a. Air shroud
- b. Cooling fan cage assembly
- c. Side wall bracket
- d. Memory modules
- e. Expansion card risers or Expansion card riser blanks
- f. Processor and heat sink module
- g. Rear OCP (if installed)
- h. Rear BOSS-N1 DC-MHS
- i. DC-SCM
- j. Internal USB memory key (if installed)
- k. Power supply units (PSU)
- l. Disconnect all the cables from the HPM board and make note of all the cable connections.

CAUTION: Take care not to damage the system identification button while removing the HPM board from the system.

CAUTION: Do not lift the system board by holding a memory module, processor, or other components.

Steps

1. Using the HPM board holder and plunger, slide the HPM board towards the front of the system.
2. At a tilted angle, lift the HPM board out of the chassis.

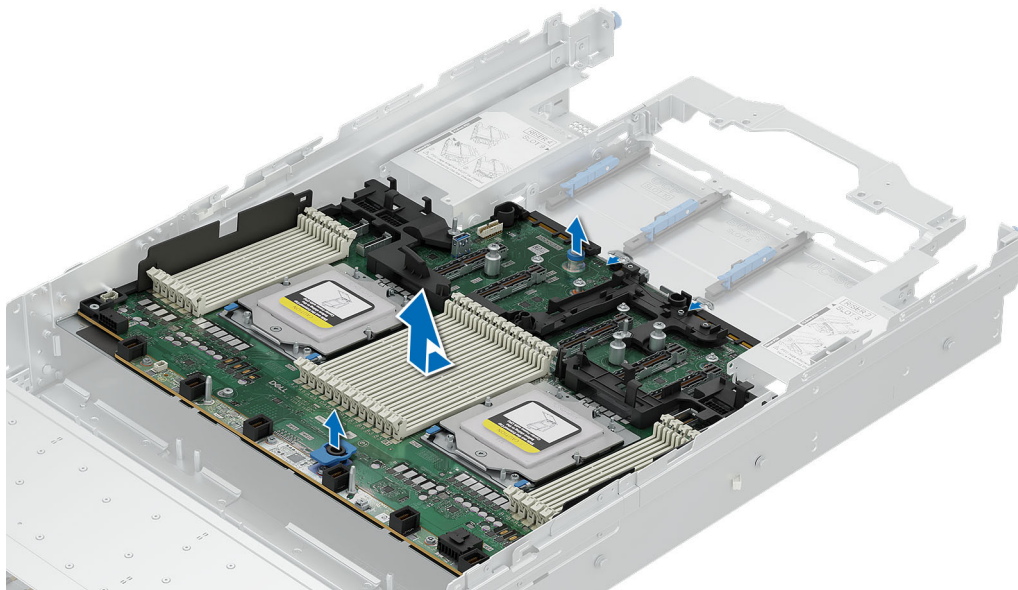

Figure 216. Removing the HPM board

Next steps

1. Install the HPM board.

Installing the HPM board

Prerequisites

1. Follow the safety guidelines listed in the [Safety instructions](#).
2. Follow the procedure listed in the [Before working inside your system](#).
3. If you are replacing the HPM board, remove all the components that are listed in the removing the HPM board section.

Steps

1. Unpack the new HPM board assembly.

 **CAUTION:** Do not lift the system board by holding a memory module, processor, or other components.

 **CAUTION:** Take care not to damage the system identification button while placing the HPM board into the chassis.

2. Holding the HPM board holder and plunger, lower the HPM board at a tilted angle into the system.
3. Slide the HPM board towards the rear of the chassis until the plunger is firmly seated into the chassis slot hole.

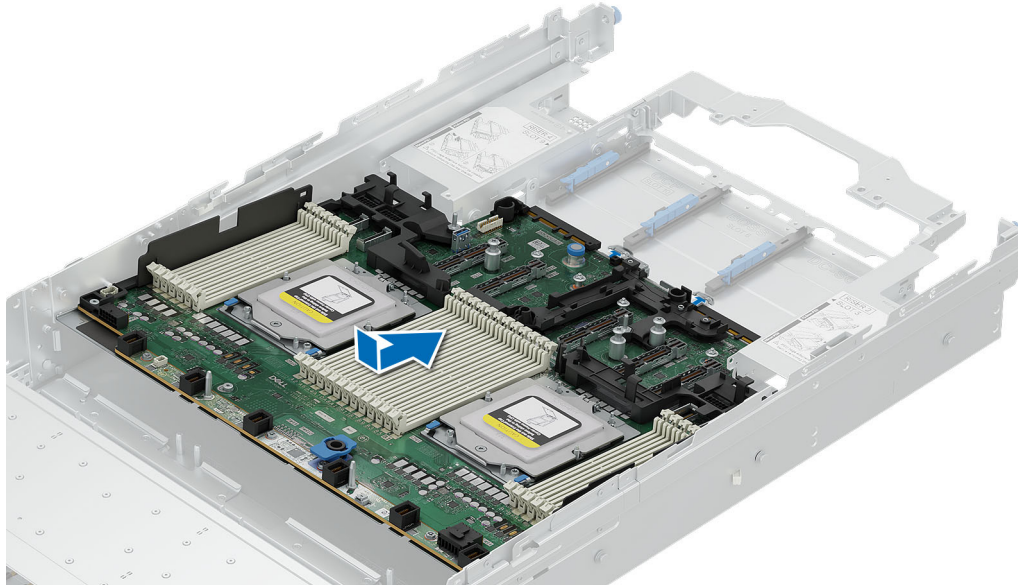



Figure 217. Installing the HPM board

Next steps

1. Replace the following components:
 - a. [Internal USB memory key \(if removed\)](#)
 - b. [OCP card \(if removed\)](#)
 - c. [BOSS-N1 DC-MHS](#)
 - d. [DC-SCM](#)
 - e. [Processor and heat sink module](#)
 - f. [Memory modules](#)
 - g. [Rear expansion card risers](#) or [rear expansion card riser blanks](#)
 - h. [Side wall bracket](#)
 - i. [Cooling fan cage assembly](#)
 - j. [Air shroud](#)
 - k. [Power supply units \(PSU\)](#)
2. Reconnect all cables to the HPM board.

 **NOTE:** Ensure that the cables inside the system are routed along the chassis wall and secured using the cable securing bracket.

3. Ensure that you perform the following steps:
 - a. Use the Easy Restore feature to restore the Service Tag. See the [Restoring the system by using the Easy Restore feature](#) section.
 - b. If the service tag is not backed up in the backup flash device, enter the system service tag manually. See the [Manually update the Service Tag](#) by using System Setup section.
 - c. Update the BIOS and iDRAC versions.
 - d. Re-enable the Trusted Platform Module (TPM). See the [Initializing the Trusted Platform Module](#) section.

4. Follow the procedure listed in [After working inside your system](#).

Control panel

This is a service technician replaceable part only.

Removing the Right control panel - primary

Prerequisites

1. Follow the safety guidelines listed in the [Safety instructions](#).
2. Follow the procedure listed in the [Before working inside your system](#).
3. [Remove the drive backplane cover](#).
4. If installed, [remove the air shroud](#).
5. [Remove the cooling fan cage assembly](#).
6. [Remove the side wall bracket](#).

Steps

1. Using the Phillips 1 screwdriver, remove the screws that secure the right control panel and cable cover to the system.
2. Remove the cable cover away from the system.
3. Disconnect the right control panel cable from the connector on the HPM board.
4. Holding the right control panel cable assembly, slide the right control panel out of the system.

NOTE: Observe the routing of the cable assembly as you remove the right control panel from the system.

NOTE: The numbers on the image do not depict the exact steps. The numbers are for representation of sequence.

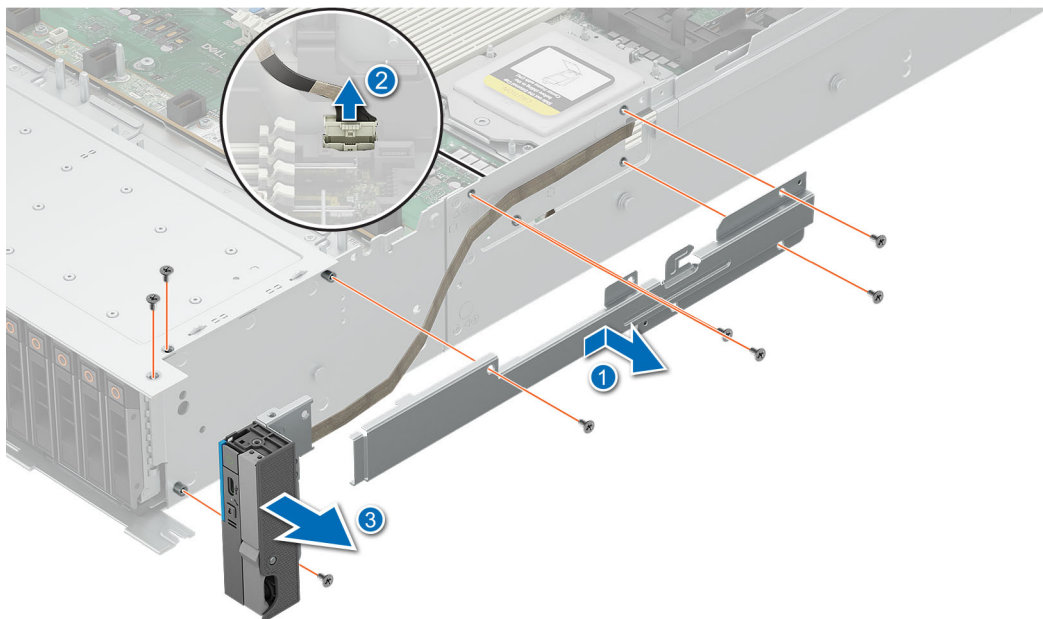

Figure 218. Removing the Right control panel - primary

Next steps

1. [Replace the control panel - primary](#).

Installing the Right control panel - primary

Prerequisites

1. Follow the safety guidelines listed in the [Safety instructions](#).
2. Follow the procedure listed in the [Before working inside your system](#).
3. [Remove the drive backplane cover](#).
4. If installed, [remove the air shroud](#).
5. [Remove the cooling fan cage assembly](#).
6. [Remove the side wall bracket](#).

Steps

1. Align and slide the right control panel into the slot on the system.
2. Route the right control panel cable through the side wall of the system.
3. Align and slide the right control panel cable cover in the slot on the system.
i **NOTE:** Route the cable properly to prevent the cable from being pinched or crimped.
4. Connect the right control panel cable to the connector on the HPM board.
5. Using the Phillips 1 screwdriver, tighten the screws that secure the right control panel and the cable cover to the system.

i **NOTE:** The numbers on the image do not depict the exact steps. The numbers are for representation of sequence.

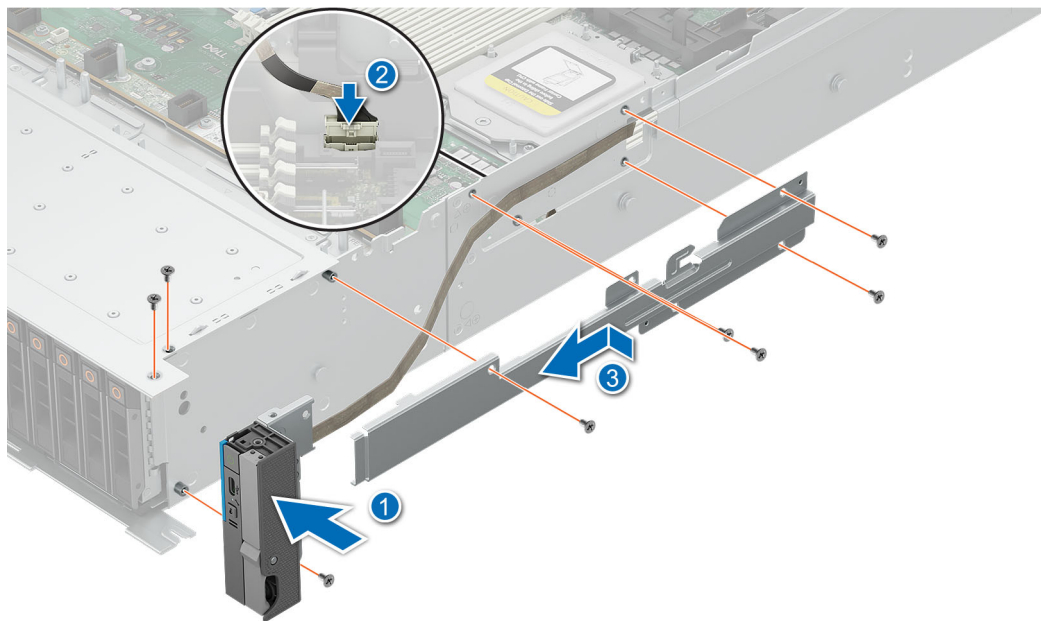

Figure 219. Installing the Right control panel - primary

Next steps

1. [Install the side wall bracket](#).
2. [Install the cooling fan cage assembly](#).
3. [Install the drive backplane cover](#).
4. [Install the air shroud](#).
5. Follow the procedure listed in [After working inside your system](#).

Removing the Left control panel - secondary with optional KVM

Prerequisites

1. Follow the safety guidelines listed in the [Safety instructions](#).
2. Follow the procedure listed in the [Before working inside your system](#).
3. [Remove the drive backplane cover](#).
4. If installed, [remove the air shroud](#).
5. [Remove the cooling fan cage assembly](#).
6. [Remove the side wall bracket](#).

Steps

1. Using the Phillips 1 screwdriver, remove the screws that secure the left control panel and the cable cover to the system.
2. Remove the cable cover away from the system.
3. Disconnect the control panel cable from the connector on the Attic board.
4. Holding the cable, slide the left control panel out of the system.

NOTE: Observe the routing of the cable as you remove the left control panel from the system.

NOTE: The numbers on the image do not depict the exact steps. The numbers are for representation of sequence.

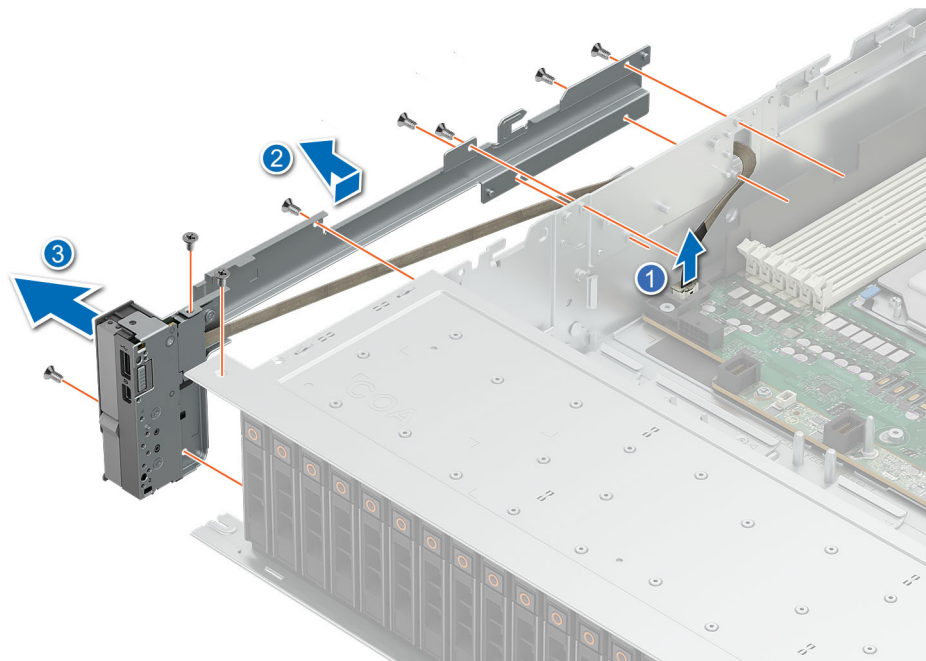

Figure 220. Removing the Left control panel - secondary

Next steps

1. [Replace the Left control panel - secondary](#).

Installing the Left control panel - secondary

Prerequisites

1. Follow the safety guidelines listed in the [Safety instructions](#).
2. Follow the procedure listed in the [Before working inside your system](#).
3. [Remove the drive backplane cover](#).

4. If installed, remove the air shroud.
5. Remove the cooling fan cage assembly.
6. Remove the side wall bracket.

Steps

1. Align and slide the left control panel in the slot on the system.
2. Route the left control panel cable through the side wall of the system.
3. Align and slide the left control panel cable cover in the slot on the system.

NOTE: Route the cable properly through the chassis side holder and the clips to prevent the cable from being pinched or crimped.

4. Connect the left control panel cable to the connector on the Attic board .
5. Using the Phillips 1 screwdriver, tighten the screws to secure the left control panel and the cable cover to the system.

NOTE: The numbers on the image do not depict the exact steps. The numbers are for representation of sequence.

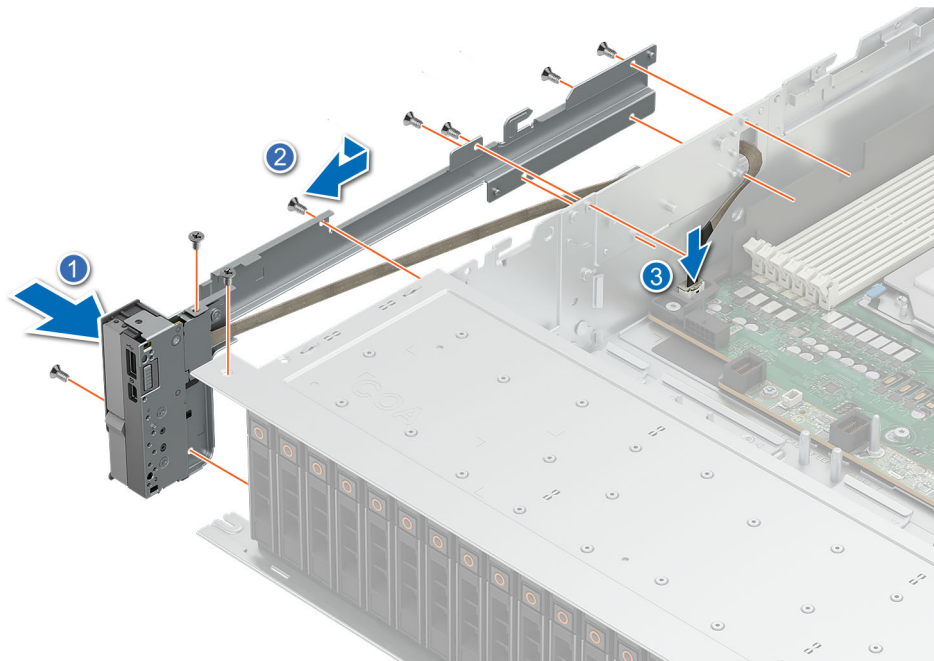

Figure 221. Installing the Left control panel - secondary

Next steps

1. Install the side wall bracket.
2. Install the cooling fan cage assembly.
3. Install the drive backplane cover.
4. Install the air shroud.
5. Follow the procedure listed in [After working inside your system](#).

Upgrade Kits

The table lists the available After Point Of Sale [APOS] kits.

Table 84. Upgrade kits

Kits	Related links to service instructions
Processor	See Installing the processor.
BOSS-N1	See Installing the BOSS-N1 controller card module .
GPU/Accelerator enablement kit	See Installing the GPU.
PERC	See Installing the PERC card.

Topics:

- [Processor upgrade kit components](#)
- [BOSS-N1 DCMHS module kit](#)
- [GPU kit](#)
- [Perc module kit](#)
- [DPU kit](#)

Processor upgrade kit components

The system supports only one processor.

Before you begin the installation or removal process, follow the [safety guidelines](#) and [before working inside the system](#) instructions.

Table 85. Processor upgrade kit components matrix

System configuration	CPU	Heatsink	FAN	Shroud
<ul style="list-style-type: none"> • 16 x 2.5-inch SAS/ SATA + 8 x U.2 or 2.5-inch NVMe RAID • 24 x 2.5-inch SAS 	2	T-Wing heat sink for CPU TDP > 400 W	<ul style="list-style-type: none"> • HPR Gold fan for CPU TDP > 300 W • HPR Platinum fan for CPU TDP > 500 W 	T-Wing shroud for CPU TDP > 400 W
<ul style="list-style-type: none"> • 8 x EDSFF E3.S Gen5 NVMe • 16 x EDSFF E3.S Gen5 NVMe • 32 x EDSFF E3.S Gen5 NVMe • 40 x EDSFF E3.S Gen5 NVMe 	2	T-Wing heat sink for CPU TDP > 400 W	HPR Platinum fan for CPU TDP > 500 W	T-Wing shroud for CPU TDP > 400 W
<ul style="list-style-type: none"> • 8 x 2.5-inch Universal • 16 x 2.5-inch SAS/ SATA • No backplane configuration 	2	T-Wing heat sink for CPU TDP > 400 W	HPR Platinum fan for CPU TDP > 500 W	T-Wing shroud for CPU TDP > 400 W
12 x 3.5-inch SAS/ SATA	2	No support for CPU TDP > 400 W	<ul style="list-style-type: none"> • HPR Gold fan for CPU TDP > 300 W 	No support for CPU TDP > 400 W

Table 85. Processor upgrade kit components matrix (continued)

System configuration	CPU	Heatsink	FAN	Shroud
			<ul style="list-style-type: none">No support for CPU TDP 320 W	

For installation procedures of the Heatsink and Processor see: [Installing the processor](#) section.

 **NOTE:** The install procedure for the remote and extended heatsinks are the same.

BOSS-N1 DCMHS module kit

The BOSS-N1 DCMHS module supports up to two M.2 SSDs. On the PowerEdge R7725 the BOSS-N1 DCMHS modules are supported at the rear of the system.

Before you begin the installation or removal process, follow the [Safety instructions](#) and [Before working inside your system](#) instructions.

Table 86. BOSS-N1 DCMHS module kit components

Components in kit	Quantity
BOSS-N1 DCMHS controller card module	1
BOSS-N1 DCMHS card carrier	2
M.2 NVMe SSD capacity label	2
BOSS-N1 DCMHS card carrier blank	1

For installation procedures of the BOSS-N1 DCMHS modules see: [Installing the BOSS-N1 DCMHS module](#) section.

GPU kit

The GPU FL kit is available for the Customer. Depending on the kit ordered, the respective components are available.

CAUTION: Do not install GPUs, network cards, or other PCIe devices on your system that are not validated and tested by Dell. Damage caused by unauthorized and invalidated hardware installation will null and void the system warranty.

WARNING: Consumer-Grade GPU should not be installed or used in the Enterprise Server products.

Table 87. Components in the full length (FL) GPU kit

Components	Cable kit for multiple GPU upgrade
L4 full-height	None
L4 low-profile	None
L40s	<ul style="list-style-type: none"> Power cable
A16	<ul style="list-style-type: none"> Power cable
H100	<ul style="list-style-type: none"> Power cable
H200	<ul style="list-style-type: none"> N/A
NVIDIA RTX Pro 6000 BSE	<ul style="list-style-type: none"> N/A

NOTE: See [expansion card installation guidelines](#) for more information about riser configuration supported for the system.

NOTE: Dual-width GPU and single-width GPU cannot be interchangeable due to riser restrictions.

NOTE: Dual-width GPU upgrade is restricted to RC4 only on the R7725.

NOTE: When customer wants to upgrade one GPU to multiple GPUs, it is restricted to the same type of GPU.

- RC4 riser only support up to 2 dual-width GPUs.
- R7725 supports up to 6 single-width L4 (FH) GPUs (no extra cables required for upgrade).

NOTE: L4 (FH & LP) is not interchangeable due to different form factors.

For installation procedures of the GPU see: [removing](#) or [installing](#) the expansion card from the expansion card riser > Removing the GPU.

NOTE: See [cable routing](#) section for more information about connecting the GPU.

Perc module kit

Before you begin the installation or removal process, follow the [safety guidelines](#) and [before working inside the system](#) instructions.

Table 88. PERC module kit components for configuration: 16 x EDSFF E3.S NVMe and 32 x EDSFF E3.S NVMe

Components in kit	Quantity
PERC bracket	1
Shroud	1
Screw 3 x 8.5 mm	4
DVD recovery (screw)	<ul style="list-style-type: none"> One for 16 x EDSFF E3.S NVMe configuration Two for 32 x EDSFF E3.S NVMe configuration

Table 88. PERC module kit components for configuration: 16 x EDSFF E3.S NVMe and 32 x EDSFF E3.S NVMe (continued)

Components in kit	Quantity
8 x EDSFF E3.S NVMe backplane	<ul style="list-style-type: none"> Two backplanes for 16 x EDSFF E3.S NVMe configuration Four backplanes for 32 x EDSFF E3.S NVMe configuration
Power cable	<ul style="list-style-type: none"> One for 16 x EDSFF E3.S NVMe configuration Two for 32 x EDSFF E3.S NVMe configuration
PCIe cable	<ul style="list-style-type: none"> Two for 16 x EDSFF E3.S NVMe configuration Four for 32 x EDSFF E3.S NVMe configuration

Table 89. PERC upgrade kit details for configuration: 16 x EDSFF E3.S NVMe and 32 x EDSFF E3.S NVMe

Backplane configuration	Upgrade from	Upgrade to	Remove card or cables	Replace with the card or cables
16 x EDSFF E3.S NVMe	Onboard controller	H975i front PERC	<ul style="list-style-type: none"> HDD filler 16 x EDSFF E3.S NVMe backplane Backplane to HPM board power cable 	<ul style="list-style-type: none"> H975i card PERC shroud Two 8 x EDSFF E3.S NVMe backplanes PERC power cable Two PERC signal cables.
32 x EDSFF E3.S NVMe	Onboard controller	H975i front PERC	32 x EDSFF E3.S NVMe backplane	<ul style="list-style-type: none"> H975i card PERC shroud Four 8 x EDSFF E3.S NVMe backplanes PERC power cable Four PERC signal cables.

Table 90. PERC module kit components for configuration: 8 x 2.5-inch Universal, 12 x 3.5-inch SATA/SAS, 16 x 2.5-inch SAS/SATA, and 24 x 2.5-inch SAS/SATA

Components in kit	Quantity
PERC signal cable	1

Table 91. PERC upgrade kit details for configuration: 8 x 2.5-inch Universal, 12 x 3.5-inch SATA/SAS, 16 x 2.5-inch SAS/SATA, and 24 x 2.5-inch SAS/SATA

Backplane configuration	Upgrade from	Upgrade to	Remove card or cables	Replace with the card or cables
<ul style="list-style-type: none"> 16 x 2.5-inch SAS/SATA 16x 2.5-inch SAS/SATA + 8x 2.5-inch (NVMe RAID) 24 x 2.5-inch SAS/SATA 	H365i front PERC	H965i front PERC	None	One PERC signal cables.
<ul style="list-style-type: none"> 8 x 2.5-inch Universal 16 x 2.5-inch SAS/SATA 16x 2.5-inch SAS/SATA RAID + 8x U.2 G4 	H365i adapter	H965i adapter	None	None

Table 91. PERC upgrade kit details for configuration: 8 x 2.5-inch Universal, 12 x 3.5-inch SATA/SAS, 16 x 2.5-inch SAS/SATA, and 24 x 2.5-inch SAS/SATA (continued)

Backplane configuration	Upgrade from	Upgrade to	Remove card or cables	Replace with the card or cables
<ul style="list-style-type: none"> 12 x 3.5-inch SAS/SATA 				

DPU kit

Before you begin the installation or removal process, follow the [safety guidelines](#) and [before working inside the system](#) instructions.

Table 92. DPU upgrade kit details

Configuration	Upgrade from	Upgrade to	Kit parts
<ul style="list-style-type: none"> 40x E3.S G5x2 + RC2 32x E3.S G5x2 + RC8 32x E3.S RAID with Dual PERC13 Controller + RC3, RC4, RC8 16x E3.S G5x4 + RC8 16x E3.S RAID with Single PERC13 Controller + RC3, RC4,RC5, RC8 8x E3.S G5x4 + RC3, RC4, RC8 16x 2.5" SAS4/SATA RAID + 8x U.2 G4 + RC3, RC8 16x 2.5" SAS4/SATA + 8x 2.5" (NVMe RAID) + RC3, RC4, RC8 16x 2.5" SAS4/SATA + 8x 2.5" (NVMe RAID) + RC3, RC4, RC8 8x 2.5" Universal + RC3, RC8 24x 2.5" SAS4/SATA + RC3, RC5, RC8 24x 2.5" SAS4/SATA + RC3, RC5, RC8 16x 2.5" SAS4/SATA RAID - Smart Flow + RC3, RC4,RC5, RC8 16x 2.5" SAS4/SATA RAID - Smart Flow + RC3, RC4,RC5, RC8 12x 3.5" SAS3/SATA RAID + RC3 No BP config + RC3, RC4, RC5 	No DPU	Single DPU (on slot 2 from R1) and Dual DPU	<ul style="list-style-type: none"> DPU power cable - R1 DPU power cable - R5

System diagnostics and indicator codes

The diagnostic indicators on the system front panel display system status during system startup.

Topics:

- [Power button LED](#)
- [System health and system ID indicator codes](#)
- [iDRAC Direct LED indicator codes](#)
- [NIC indicator codes](#)
- [Power supply unit indicator codes](#)
- [Drive indicator codes](#)
- [Using system diagnostics](#)

Power button LED

The power button LED is on the front panel of your system.



Figure 222. Power button LED

Table 93. Power button LED

Power button LED indicator code	Condition
Off	System is not operating or idle in standby power mode regardless of the power supply available.
On	System is operating, one or more of the non-standby power supply units are active.
Slowly blinking	System is performing powering on sequence, and is still booting.

System health and system ID indicator codes

The system health and system ID indicator is located on the right control panel of the system.



Figure 223. System health and system ID indicator

Table 94. System health and system ID indicator codes

System health and system ID indicator code	Condition
Solid blue	Indicates that the system is powered on, is healthy, and system ID mode is not active. Press the system ID button to switch to system ID mode.
Blinking blue	Indicates that the system ID mode is active. Press the system ID button to switch to system health mode.
Blinking amber	Indicates that the system is experiencing a fault. Check the System Event Log for specific error messages. EEMI guide

iDRAC Direct LED indicator codes

The iDRAC Direct LED indicator lights up to indicate that the port is connected and is being used as a part of the iDRAC subsystem.

You can configure iDRAC Direct by using a USB to USB Type-C cable, which you can connect to your laptop or tablet. Cable length should not exceed 3 feet (0.91 meters). Performance could be affected by cable quality. The following table describes iDRAC Direct activity when the iDRAC Direct port is active:

Table 95. iDRAC Direct LED indicator codes

iDRAC Direct LED indicator code	Condition
Solid green for two seconds	Indicates that the laptop or tablet is connected.
Blinking green (on for two seconds and off for two seconds)	Indicates that the laptop or tablet connected is recognized.
Powers off	Indicates that the laptop or tablet is unplugged.

NIC indicator codes

Each NIC on the back of the system has indicators that provide information about the activity and link status. The activity LED indicator indicates if data is flowing through the NIC, and the link LED indicator indicates the speed of the connected network.

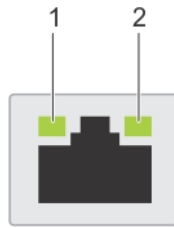

Figure 224. NIC indicator codes

1. Link LED indicator
2. Activity LED indicator

Table 96. NIC indicator codes

NIC indicator codes	Condition
Link and activity indicators are off.	Indicates that the NIC is not connected to the network.
Link indicator is green, and activity indicator is blinking green.	Indicates that the NIC is connected to a valid network at its maximum port speed, and data is being sent or received.
Link indicator is amber, and activity indicator is blinking green.	Indicates that the NIC is connected to a valid network at less than its maximum port speed, and data is being sent or received.
Link indicator is green, and activity indicator is off.	Indicates that the NIC is connected to a valid network at its maximum port speed, and data is not being sent or received.
Link indicator is amber, and activity indicator is off.	Indicates that the NIC is connected to a valid network at less than its maximum port speed, and data is not being sent or received.
Link indicator is blinking green, and activity is off.	Indicates that the NIC identify is enabled through the NIC configuration utility.

Power supply unit indicator codes

AC and DC power supply units (PSUs) have an illuminated translucent handle that serves as an indicator. The indicator shows if power is present or if a power fault has occurred.

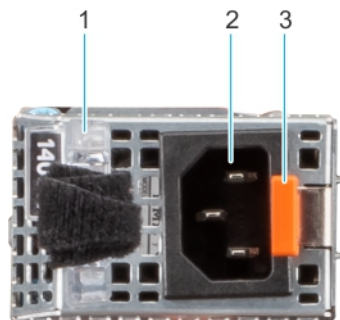

Figure 225. AC PSU status indicator

1. AC PSU handle
2. Socket
3. Release latch

Table 97. AC and DC PSU status indicator codes

Power indicator codes	Condition
Green	Indicates that a valid power source is connected to the PSU and the PSU is operational.
Blinking amber	Indicates an issue with the PSU.
Not powered on	Indicates that the power is not connected to the PSU.
Blinking green	Indicates that the firmware of the PSU is being updated. ⚠ CAUTION: Do not disconnect the power cord or unplug the PSU when updating firmware. If firmware update is interrupted, the PSUs will not function.
Blinking green and powers off	When hot-plugging a PSU, it blinks green five times at a rate of 4 Hz and powers off. This indicates a PSU mismatch due to efficiency, feature set, health status, or supported voltage. ⚠ CAUTION: If two PSUs are installed, both the PSUs must have the same type of label; for example, Extended Power Performance (EPP) label. Mixing PSUs from previous generations of PowerEdge servers is not supported, even if the PSUs have the same power rating. This results in a PSU mismatch condition or failure to power on the system. ⚠ CAUTION: If two PSUs are used, they must be of the same type and have the same maximum output power. ⚠ CAUTION: When correcting a PSU mismatch, replace the PSU with the blinking indicator. Swapping the PSU to make a matched pair can result in an error condition and an unexpected system shutdown. To change from a high output configuration to a low output configuration or vice versa, you must power off the system. ⚠ CAUTION: AC PSUs support both 240 V and 120 V input voltages with the exception of Titanium PSUs, which support only 240 V. When two identical PSUs receive different input voltages, they can output different wattages, and trigger a mismatch.

Drive indicator codes

The LEDs on the drive carrier indicates the state of each drive. Each drive carrier has two LEDs: an activity LED (green) and a status LED (bicolor, green/amber). The activity LED blinks whenever the drive is accessed.



Figure 226. Drive indicators

1. Drive activity LED indicator

2. Drive status LED indicator
3. Drive capacity label

NOTE: If the drive is in the Advanced Host Controller Interface (AHCI) mode, the status LED indicator does not power on.

NOTE: Drive status indicator behavior is managed by Storage Spaces Direct. Not all drive status indicators may be used.

Table 98. Drive indicator codes

Drive status indicator code	Condition
Blinks green twice per second	Indicates that the drive is being identified or preparing for removal.
Not powered on	Indicates that the drive is ready for removal. NOTE: The drive status indicator remains off until all drives are initialized after the system is powered on. Drives are not ready for removal during this time.
Blinks green, amber, and then powers off	Indicates that there is an expected drive failure.
Blinks amber four times per second	Indicates that the drive has failed.
Blinks green slowly	Indicates that the drive is rebuilding.
Solid green	Indicates that the drive is online.
Blinks green for three seconds, amber for three seconds, and then powers off after six seconds	Indicates that the rebuild has stopped.

EDSFF E3.S drive led codes

The LEDs on the drive carrier indicate the state of each drive. The LEDs on the EDSFF E3.S drive have two LEDs: an activity LED (green) and a locate/fault LED (blue/amber). The activity LED blinks whenever the drive is accessed.



Figure 227. EDSFF E3.S drive indicators

1. Drive activity LED indicator
2. Drive status LED indicator
3. Drive capacity label

EDSFF E3.S drive led codes

E3.S hard drives have Green LED and Blue/Amber LED.

- Green LED shows : Drive power status , Activity
- Blue/Amber LED shows: Drive Fault, Locate

EDSFF indicator behavior

Table 99. EDSFF indicator behavior

Pattern Name	Description	Blue Element	Amber Element
Locate	This device is being identified.	ON (1 sec ON 1 sec OFF)	OFF
Fault	The device is in a fault condition.	OFF	ON (2 sec ON 1 sec OFF)
N/A	This device does not have fault or locate device.	OFF	OFF

NOTE: Locate behavior overrides Fault state.

Green LED

The green LED is driven and controlled by the device. The two functions for this LED are defined as follows:

- Power: This function indicates that the device has power and has no issues with its power regulation. Once the green LED is ON, it shall either remain ON or blink at the activity frequency unless the device determines power is no longer within its operating range.
- Activity: This function indicates if the device is being used.

Table 100. LED and device state per function for Green LED

Function/Device state	LED state
Power ON/Device is powered, no activity occurring.	ON
Activity/Device is powered, host initiated I/O activity occurring.	4 Hz nominal blink rate
Power OFF/Device is not powered.	OFF

Using system diagnostics

If you experience an issue with the system, run the system diagnostics before contacting Dell for technical assistance. The purpose of running system diagnostics is to test the system hardware without using additional equipment or risking data loss. If you are unable to fix the issue yourself, service and support personnel can use the diagnostics results to help you solve the issue.

Dell Embedded System Diagnostics

 **NOTE:** The Dell Embedded System Diagnostics is also known as Enhanced Pre-boot System Assessment (ePSA) diagnostics.

The Embedded System Diagnostics provide a set of options for particular device groups or devices allowing you to:

- Run tests automatically or in an interactive mode
- Repeat tests
- Display or save test results
- Run thorough tests to introduce additional test options to provide extra information about the failed device(s)
- View status messages that inform you if tests are completed successfully
- View error messages that inform you of issues encountered during testing

Running the Embedded System Diagnostics from Boot Manager

Run the Embedded System Diagnostics (ePSA) if your system does not boot.

Steps

1. When the system is booting, press F11.
2. Use the up arrow and down arrow keys to select **System Utilities > Launch Diagnostics**.
3. Alternatively, when the system is booting, press F10, select **Hardware Diagnostics > Run Hardware Diagnostics**. The **ePSA Pre-boot System Assessment** window is displayed, listing all devices detected in the system. The diagnostics starts executing the tests on all the detected devices.

System diagnostic controls

Table 101. System diagnostic controls

Menu	Description
Configuration	Displays the configuration and status information of all detected devices.

Table 101. System diagnostic controls (continued)

Menu	Description
Results	Displays the results of all tests that are run.
System health	Provides the current overview of the system performance.
Event log	Displays a time-stamped log of the results of all tests run on the system. This is displayed if at least one event description is recorded.

HPM board connectors and DIP Switches

This topic provides some basic and specific information about DIP switches. DIP switches on the HPM board help to disable the system and reset the passwords. To set the switches correctly, you must know the location on the HPM board. .

Topics:

- [HPM board jumpers and connectors](#)
- [DIP Switch settings](#)
- [Disabling a forgotten password](#)

HPM board jumpers and connectors

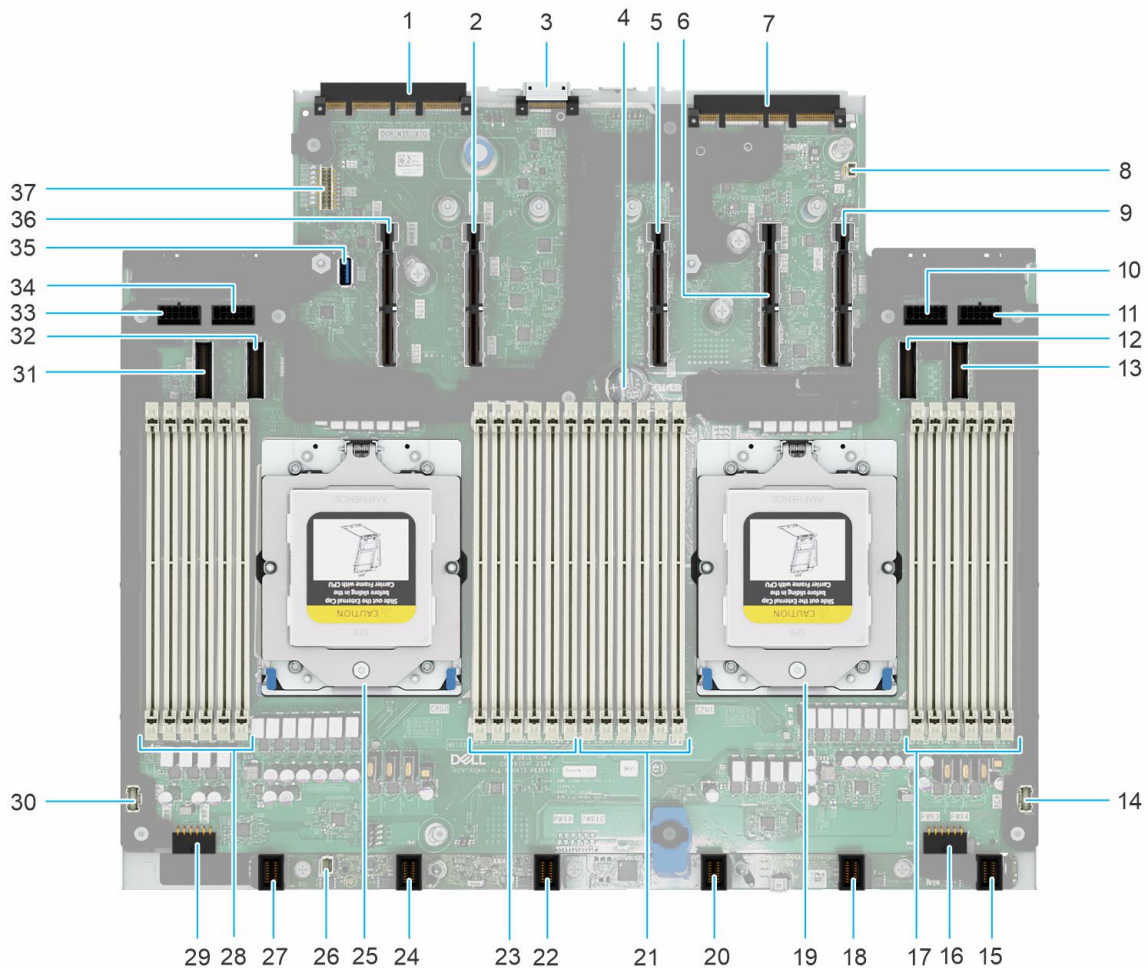

Figure 228. HPM board jumpers and connectors

Table 102. HPM board jumpers and connectors

Item	Connector
1	OCP NIC 3.0 connector
2	Riser connector 4 - requires CPU 0 (SL13/SL14/PWR13/PWR14)





Table 102. HPM board jumpers and connectors (continued)

Item	Connector
3	BOSS connector
4	Coin cell battery
5	Riser connector 3 - requires CPU 1 (SL15/SL16/PWR15/PWR16)
6	Riser connector 1 - requires CPU 1 (SL17/SL18/PWR17/PWR18)
7	DC-SCM connector
8	Intrusion Switch Connector
9	Riser Connector 2 - Requires CPU 1 (SL19/SL20/PWR19/PWR20)
10	Power Connector 21/22 (PWR21/PWR22)
11	Power Connector 23/24 (PWR23/PWR24)
12	PCIe Connector 21 (SL21_CPU 1)
13	PCIe Connector 22 (SL22_CPU 1)
14	Primary Control Panel Connector
15	Fan 6
16	Power Connector 3/4 (PWR3/PWR4)
17	DIMMs for CPU 1
18	Fan 5
19	CPU 1
20	Fan 4
21	DIMMs for CPU 1
22	Fan 3
23	DIMMs for CPU 0
24	Fan 2
25	CPU 0
26	Fan Board
27	Fan 1
28	DIMMs for CPU 0
29	Power Connector 1/2 (PWR1/PWR2)
30	Secondary Control Panel Connector
31	PCIe Connector 9 (SL9_CPU 0)
32	PCIe Connector 10 (SL10_CPU 0)
33	Power Connector 5/6 (PWR5/PWR6)
34	Power Connector 7/8 (PWR7/PWR8)
35	Internal USB
36	Riser Connector 5 - Requires CPU 0 (SL11/SL12/PWR11/PWR12)
37	DIP Switch for NVRAM/PWRD

DIP Switch settings

For information about resetting the password, see the [Disabling a forgotten password](#) section.

Table 103. DIP Switch settings

Jumper	Setting	Description
NVRAM_CLR		OFF (default): The BIOS settings are retained at system boot.
		ON: The BIOS settings cleared at system boot.
PWRD_DIS		OFF (default): The BIOS password is enabled.
		ON: The BIOS password is disabled.

CAUTION: You should be cautious when changing the BIOS settings. The BIOS interface is designed for advanced users. Any changes in the setting might prevent your system from starting correctly and may even result in data loss.

Disabling a forgotten password

The software security features of the system include a system password and a setup password. The password DIP switch enables or disables password features and clears any passwords currently in use.

Prerequisites

CAUTION: Many repairs may only be done by a certified service technician. You should only perform troubleshooting and simple repairs as authorized in your product documentation, or as directed by the online or telephone service and support team. Damage due to servicing that is not authorized by Dell is not covered by your warranty. Read and follow the safety instructions that are shipped with your product.

Steps

1. Power off the system and all attached peripherals. Disconnect the system from the electrical outlet, and disconnect the peripherals.
2. [Remove the system cover.](#)
3. Move the DIP switch (PWRD_DIS) on the HPM board from **OFF** position to **ON** position.

NOTE: Use a plastic scribe to change the DIP switch settings.

4. [Replace the system cover.](#)

NOTE: The existing passwords are not disabled (erased) until the system boots with the DIP switch in the **ON** position. However, before you assign a new system and/or setup password, you must move the DIP switch back to **OFF** position.

NOTE: If you assign a new system and/or setup password with the DIP switch in the **ON** position, the system disables the new passwords the next time it boots.

5. Reconnect the peripherals and connect the system to the electrical outlet, and then power on the system.

6. Power off the system.
7. [Remove the system cover.](#)
8. Move the DIP switch (PWRD_DIS) on the HPM board from **ON** position to **OFF** position.
9. [Replace the system cover.](#)
10. Reconnect the peripherals and connect the system to the electrical outlet, and then power on the system.
11. Assign a new system and/or setup password.

Getting Help

Topics:

- [Recycling or End-of-Life service information](#)
- [Contact Dell Technologies](#)
- [Accessing system information by using MyDell](#)
- [Receiving automated support with Secure Connect Gateway \(SCG\)](#)

Recycling or End-of-Life service information

Take back and recycling services are offered for this product in certain countries. If you want to dispose of system components, visit [How to Recycle](#) and select the relevant country.

Contact Dell Technologies

Dell provides online support, mobile support, and onsite service options. If you do not have an active Internet connection, you can find Dell contact information on your invoice, packing slip, bill, or Dell product catalog. The availability of services varies depending on the country or region and product, and some services may not be available in your area. You can contact Dell for sales, technical support, or customer service issues.

Steps

1. Go to [Dell Support](#) and follow the prompts.
2. For contact details of Dell Global Technical Support, click [Contact Technical Support](#).

Accessing system information by using MyDell

You can use the MyDell label located on the Express service tag in the front of the PowerEdge system, to access information about PowerEdge R7725 system.

Prerequisites

Ensure that your smartphone or tablet has a QR code scanner installed.

The MyDell includes the following information about your system:

- How-to videos
- Reference materials, including the Installation and Service Manual, and mechanical overview.
- The system service tag to quickly access the specific hardware configuration and warranty information.
- A direct link to Dell to contact technical support and sales teams.

Steps

Go to product-specific page in [PowerEdge Manuals](#) or scan the model-specific QR code on your system using your smartphone or tablet.

MyDell label for PowerEdge R7725 system resources



Figure 229. MyDell label for PowerEdge R7725 system

Receiving automated support with Secure Connect Gateway (SCG)

Dell Secure Connect Gateway (SCG) is an optional Dell Services offering that automates technical support for your Dell server, storage, and networking devices. By installing and setting up a Secure Connect Gateway (SCG) application in your IT environment, you can receive the following benefits:

- Automated issue detection — Secure Connect Gateway (SCG) monitors your Dell devices and automatically detects hardware issues, both proactively and predictively.
- Automated case creation — When an issue is detected, Secure Connect Gateway (SCG) automatically opens a support case with Dell Technical Support.
- Automated diagnostic collection — Secure Connect Gateway (SCG) automatically collects system state information from your devices and uploads it securely to Dell. This information is used by Dell Technical Support to troubleshoot the issue.
- Proactive contact — A Dell Technical Support agent contacts you about the support case and helps you resolve the issue.

The available benefits vary depending on the Dell Service entitlement purchased for your device. For more information about Secure Connect Gateway (SCG), go to [secureconnectgateway](https://www.dell.com/support/secureconnectgateway).

Documentation resources

This section provides information about the documentation resources for your system.

To view the document that is listed in the documentation resources table:

- From the Dell support site:
 1. Click the documentation link that is provided in the Location column in the table.
 2. Click the required product or product version.

 **NOTE:** To locate the model number, see the front of your system.

3. On the Product Support page, click **Documentation**.
- Using search engines:
 - Type the name and version of the document in the search box.

Table 104. Additional documentation resources for your system

Task	Document	Location
Setting up your system	For more information about installing and securing the system into a rack, see the Rail Installation Guide included with your rail solution. For information about setting up your system, see the <i>Getting Started Guide</i> document that is shipped with your system.	PowerEdge Manuals
Configuring your system	For information about the iDRAC features, configuring and logging in to iDRAC, and managing your system remotely, see the Integrated Dell Remote Access Controller User's Guide. For information about understanding Remote Access Controller Admin (RACADM) subcommands and supported RACADM interfaces, see the RACADM CLI Guide for iDRAC. For information about Redfish and its protocol, supported schema, and Redfish Eventing implemented in iDRAC, see the Redfish API Guide. For information about iDRAC property database group and object descriptions, see the Attribute Registry Guide.	PowerEdge Manuals
	For information about earlier versions of the iDRAC documents. To identify the version of iDRAC available on your system, on the iDRAC web interface, click ? > About .	iDRAC Manuals
	For information about installing the operating system, see the operating system documentation.	Operating System Manuals

Table 104. Additional documentation resources for your system (continued)

Task	Document	Location
	For information about updating drivers and firmware, see the Methods to download firmware and drivers section in this document.	Drivers
Managing your system	For information about systems management software offered by Dell, see the Dell OpenManage Systems Management Overview Guide.	PowerEdge Manuals
	For information about setting up, using, and troubleshooting OpenManage, see the Dell OpenManage Server Administrator User's Guide.	OpenManage Manuals
	For information about installing and using Dell SupportAssist, see the Dell SupportAssist Enterprise User's Guide.	serviceability tools
	For information about partner programs enterprise systems management, see the OpenManage Connections Enterprise Systems Management documents.	OpenManage Manuals
Working with the Dell PowerEdge RAID controllers	For information about understanding the features of the Dell PowerEdge RAID controllers (PERC), Software RAID controllers, or BOSS card and deploying the cards, see the Storage controller documentation.	Storage Controller Manuals
Understanding event and error messages	For information about the event and error messages generated by the system firmware and agents that monitor system components, see the EEMI guide.	EEMI guide
Troubleshooting your system	For information about identifying and troubleshooting the PowerEdge server issues, see the Server Troubleshooting Guide.	PowerEdge Manuals